

# elcom

LA LIBERTÉ DE CONCEVOIR

## Modular transfer systems

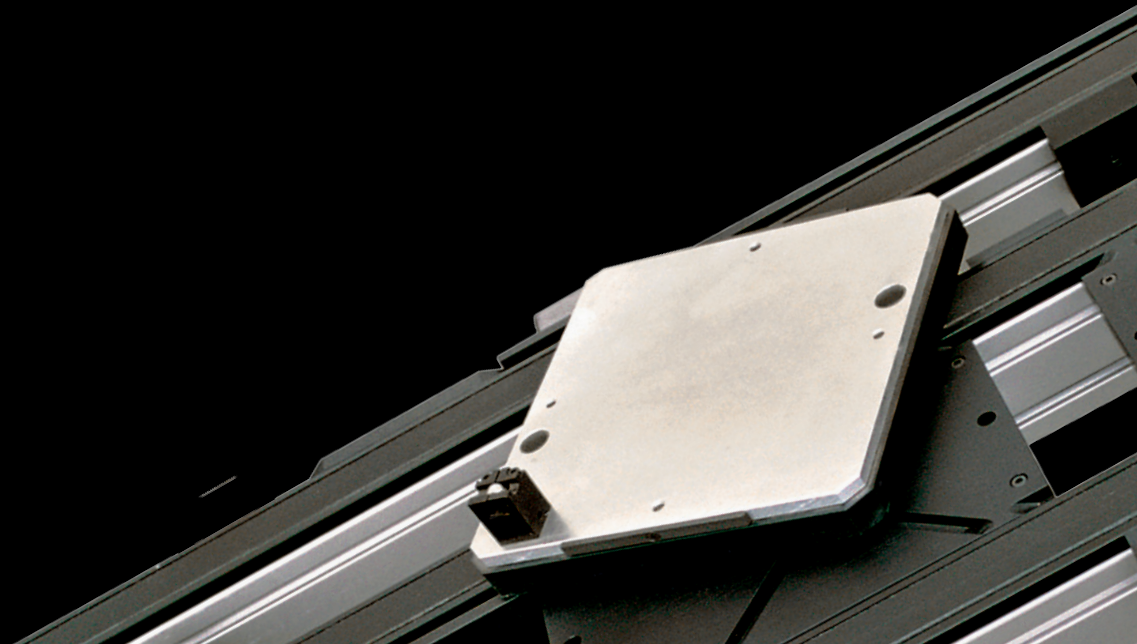

# elcom

LA LIBERTÉ DE CONCEVOIR



## FRENCH INDUSTRIAL LEADER

**elcom** has brought innovating solutions to the industry. Our approach offers a complete freedom of design thanks to a unique range of flat belt conveyor and modular transfer systems.

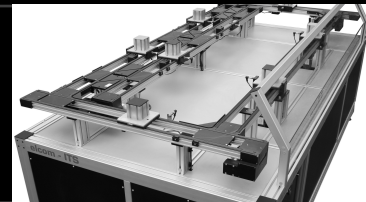

## EXCLUSIVE item PARTNER

Our partnership with the German company **item** since 1986 has opened a large expertise field and a worldwilde recognized network. elcom's flat belt conveyor design, constructed from item's range of profiles, enables a great modularity.



## GEOGRAPHICAL PRESENCE

### Europe

France  
Germany  
Italy  
Benelux  
Spain

### Denmark

Finland  
Norway  
Sweden

### North America

USA  
Canada

### South America

### Australia

### Asia

China  
India  
Malaysia  
Singapore

## COMPLETE RANGE AND NEW PRODUCTS

Our creations result from a large range of products which is regularly enlarged by novelties. They offer unlimited possibilities in terms of industrial modularity.

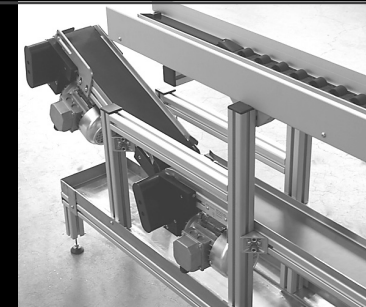

## SERVICES

- x Strong production capacity and very high reactivity
- x Important stock, fast delivery
- x Preparation for kit delivery
- x Assembly of complete sets
- x Quotations based on customers' drawings and sketches
- x Technical advice
- x CAD files library
- x Fast prototype abilities



[www.elcom-automation.com](http://www.elcom-automation.com)



# Modular transfer systems

**elcom**'s modular transfer systems, built from **item**'s range of profiles enable a great modularity.

Modular industrial system adapted for the realization of your assembly lines with automatic or manually operated work stations.

Workpiece carriers are conveyed on two parallel belts which facilitate the implementation of stoppers, positioning units, accessories...

Retractable pins, located under the workpiece carrier, allow:

- > guiding the workpiece carrier with 4 pins on straight sections,
- > guiding the workpiece carrier round bends with 2 pins (the other being retracted).

The perfect complementarity between transfer systems, profiles and flat belt conveyors will facilitate the solving and realization of your ideas.

TRANSFERS TLM 1000, 1500, 2000, 5000

**elcom**

LA LIBERTÉ DE CONCEVOIR

TRANSFER





Example of transfer **ITS 24 V**

TLM 1500 with :

workpiece carriers 150x150

motorization 24 V

positioning units 24 V

stoppers 24 V



**elcom ITS 24 V**



## TECHNOLOGICAL INNOVATIONS

Transfer system **elcom ITS 24 V**

# New concept 24 V future-oriented

**elcom ITS 24 V** is a new, ingenious **elcom** concept which provides numerous advantages:

- **Low energy consumption**
- **Reduction of sound level (electric distributor valves are removed)**
- **Concept Plug and Play**
- **Cost saving installation, cost reduction of commissioning and integration**
- **Easy to use, it is possible to control the system with a network (bus system)**

It is also easy to use:

- **Electronic control of the motor parameters (acceleration, speed, slowdown),**
- **Can be directly controlled by a network (bus system),**
- **Cams of actuators can be adjusted by potentiometer.**

**It is now possible to stop the motor at any moment without any damage risk.**

**The speed can be adjusted directly into the motor with a simple computer.**

**No air which means : no dust/ no oil.**

**Important** : the new **elcom ITS 24 V** concept is perfectly suitable to use with the **elcom** pneumatic transfer system.

All parts are modular, the user can choose what he prefers.



**elcom ITS 24 V**

this logo allow to identify easily components which belong to this concept, inside the catalog.

## Transfer system **elcom ITS 24 V** - Comparative table of energy consumptions

24 V  
380 V

ENERGY	Load< 1Kg	Load=10kg	Load=20Kg	Load=30Kg	Power
STOPPER-CAM-24 V servomotor	< 1 w	< 1 w	< 1 w	< 1 w	0,15 sec/cycle
STOPPER-CAM-Pneumatic VALVE	6 w	6 w	6 w	6 w	0,4 sec/cycle
TLM 1500 MOTOR FOR UNIT 24 V	7,2 w	11,3 w	13,7 w	18,5 w	can be stopped
TLM 1500 MOTOR FOR UNIT 400 V	150 w	>150 w	>150 w	>150 w	permanent

Sample for a loop working 3x8 shifts- 48 weeks --> the machine runs 7 728 hours

Cycle time = 6 sec

12 motors

20 stoppers

Kwxh cost = 0,24 €

	Hours nb	Power	Cost/hour	Cost	
20 x Stoppers 24 V	10 304	0,001	0,24	2,47 €	
20 x Pneumatic stoppers	27 377	0,006	0,24	39,42 €	
12 x Motors 24 V average 10 W **	74 736	0,010	0,24	179,37 €	
12 x Motors 400 V average 180 W	92 736	0,180	0,24	4 006,20 €	<b>Cost-saving (per year)</b>
					<b>3 864 €</b>

Conveying units 24 V can be stopped when work stations are saturated.

To have a maximum economic benefit, it is advisable to place upstream saturation detectors as close as possible of work station.

Energy reporting  
on a TLM 1500

## Power calculation TLM 2000 - Loads in accumulation

**For 9 m/min:**

- 0 kg : 450 mA -> 10,8 W
- 10 kg : 850 mA -> 20,4 W
- 20 kg : 1 300 mA -> 31,2 W
- 50 kg : 2 400 mA -> 57,6 W

Energy reporting for  
elcom GmbH



## TECHNOLOGICAL INNOVATIONS

Transfer system **elcom ITS** 24 V TLM 1500

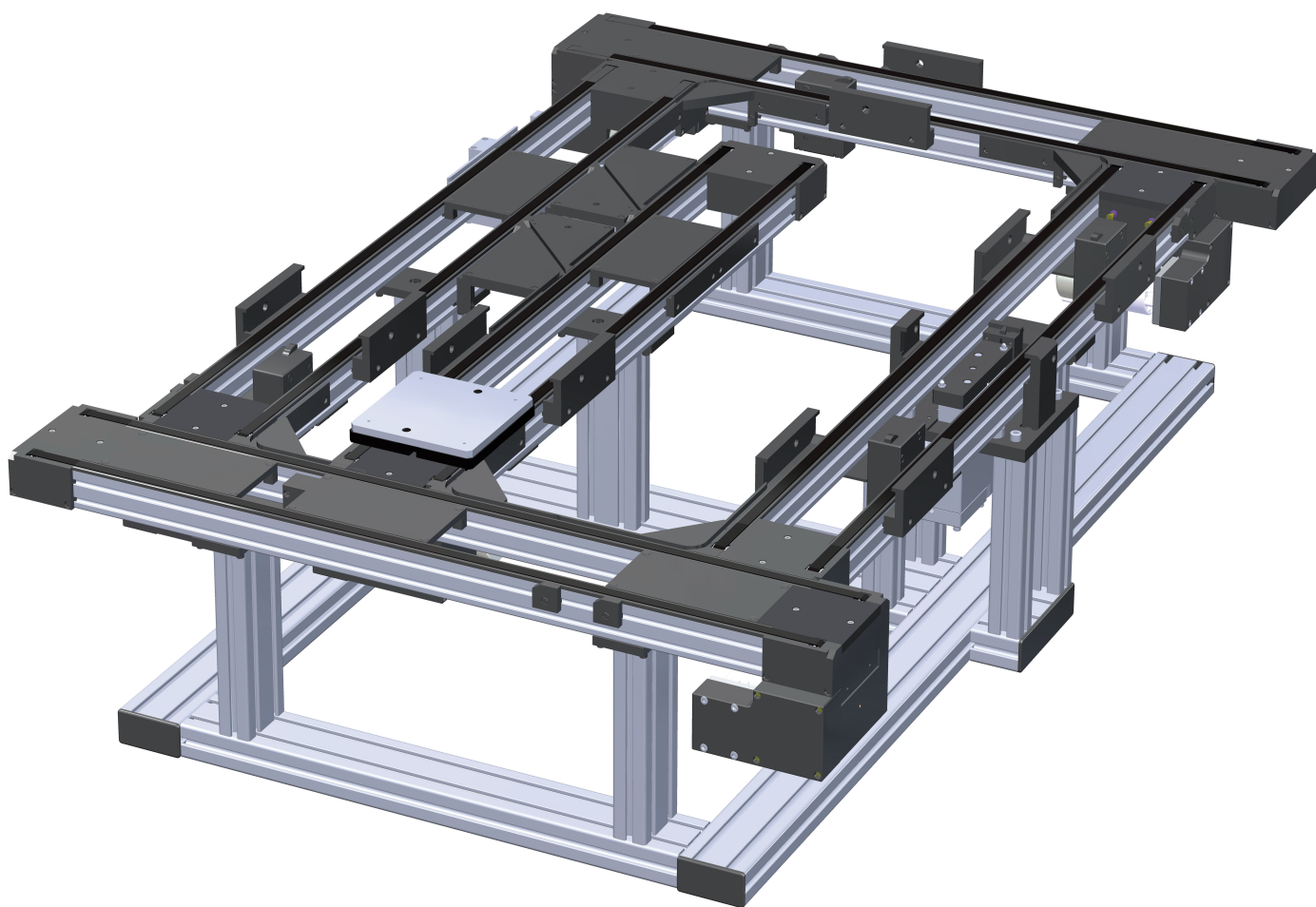

**elcom ITS 24 V**

## Transfer system Module Heavy loads

Module Heavy loads is an option integrated into the guide belt which enables to increase the performances of the transfer TLM. It is fitted instead of the standard guide belt.



The benefits of this option are numerous:

- **Significant increase of the load carried by the transfer (x2.5 the nominal load)**
- **Easy and quick installation of modules in existing units**
- **Great modularity: quick replacement of standard guiding belt by Module Heavy loads with the possibility to combine them**

**Important:** the new **Module Heavy loads** can be perfectly combined with the **elcom** transfer range TLM 2000 flat belt.

## The operating principle of workpiece carriers

Our transfer systems operate with standard workpiece carriers on which a customized fitting of conveyed workpiece is fixed. Combined with transport units, stoppers, positioning units, lifts and many standard modules, our workpiece carrier systems offer many lay-outs for transport and part supply.

**elcom** differentiates itself from traditional transfer systems through an ingenious system of retractable pins located under the workpiece carrier (shown in red). They enable the workpiece guidance in straight lines and to make curves in cams.

Results: low cost of implementation with a simplified automation, a better flow of workpiece carrier, a reduced cycle time and reduced number of workpiece carriers.

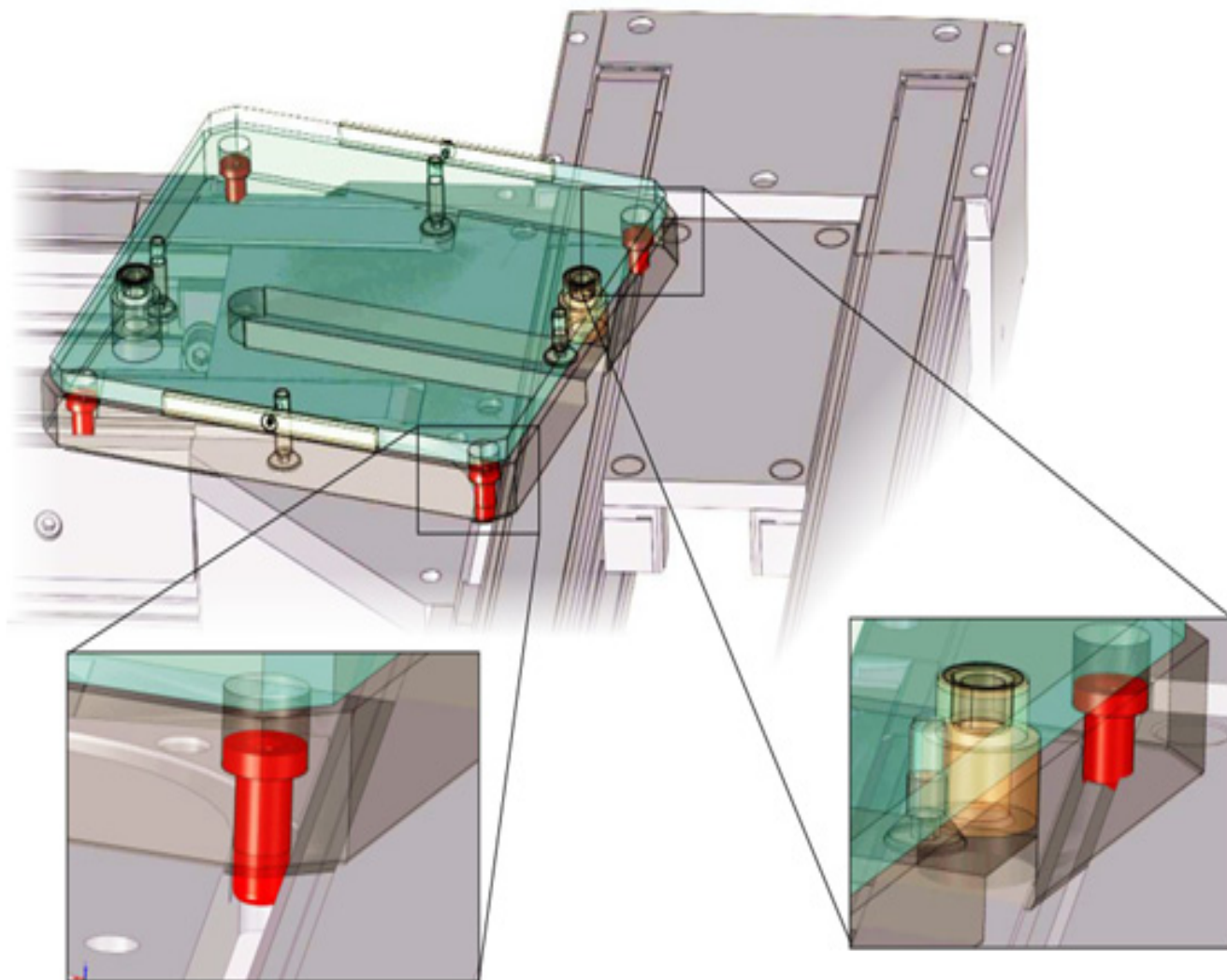

Two main tasks are fulfilled:

The first task is the transport and the management of workpiece carriers.

This is done by means of transport modules based on double belt conveyors. The conveying of workpiece carriers to the desired location is carried out through cams, standard returns and lifts.

The second task is the stop and the positioning of workpiece carriers.

These are provided by stoppers (e.g. manual supply of workpiece carriers) and positioning units (e.g. robot loading). Standard modules are provided for each specific stage of the process (e.g. press positioning unit, returns...).

The benefits of this well-designed concept can also be noticed in the servicing and maintenance as less actuators and parts have to be maintained. Moreover, maintenance work can be carried out even on an operating machine, which helps keeping the production line available.

## Overview of technical data

	TLM 1000	TLM 1500	TLM 2000			TLM 5000
Workpiece carriers (mm)	105 x 105  105 x 155	155 x 155	200 x 200 200 x 250 200 x 300 300 x 300 300 x 400 400 x 400			500 x 500 500 x 800 500 x 1000* 600 x 600 600 x 800 600 x 1000* 800 x 800 1000 x 1000 (*option 1500)
Load/workpiece carrier (daN)	2	4	10			50
Speed (m/min)						
Flat belt	10-15-20		9-15-19			
Timing belt	12-16	12-16	14 (heavy)			10-12
Length of conveying unit						
Mini	500	500	500			500
Maxi	3160	3160	6250 6160 (light)			6000
Maxi accumulation load per motor (daN)						
Flat belt	25 / 3 m		100 / 6 m 60 / 6 m (direct)			
Timing belt	35 / 3 m	35 / 3 m	60 / 6 m (light) 150 / 6 m (heavy)			
Absolved maximum load (daN) (without accumulation)						
Flat belt	50 / 3 m		200 / 6 m 120 / 6 m (direct)			
Timing belt	70 / 3 m	70 / 3 m	120 / 6 m (light) 300 / 6 m (heavy)			400 or 75%
Motor power flat belt (380 V three-phase)	0,09 KW-0,4 A		V	KW	A	
			9	0,25	0,68	
			15	0,37	1,24	
			19	0,55	1,60	
Motor power timing belt (380 V three-phase)	0,09 KW-0,4 A	0,09 KW-0,4 A	V	KW	A	
			14	0,55	1,60	0,25 KW - 0,83 A

### Note:

Solutions exist to handle larger loads per workpiece carrier. A complete system customization of the configuration (layout, cycle time, etc.) is possible after consultation with our technical office.

Please contact us at +33(0)4-74-43-99-61 or per mail at: [elcom@elcom.fr](mailto:elcom@elcom.fr)

## Elcomodularity

According to the requirements of the manufacturing process, different kinds of modular designs are possible.

The design of the line can evolve in several stages.

### Example:

1) Interchangeability of a module

- 4 fixing screws only
- No machining
- No adjusting

2) Addition of a derivation

- 6 fixing screws
- No machining
- No adjusting

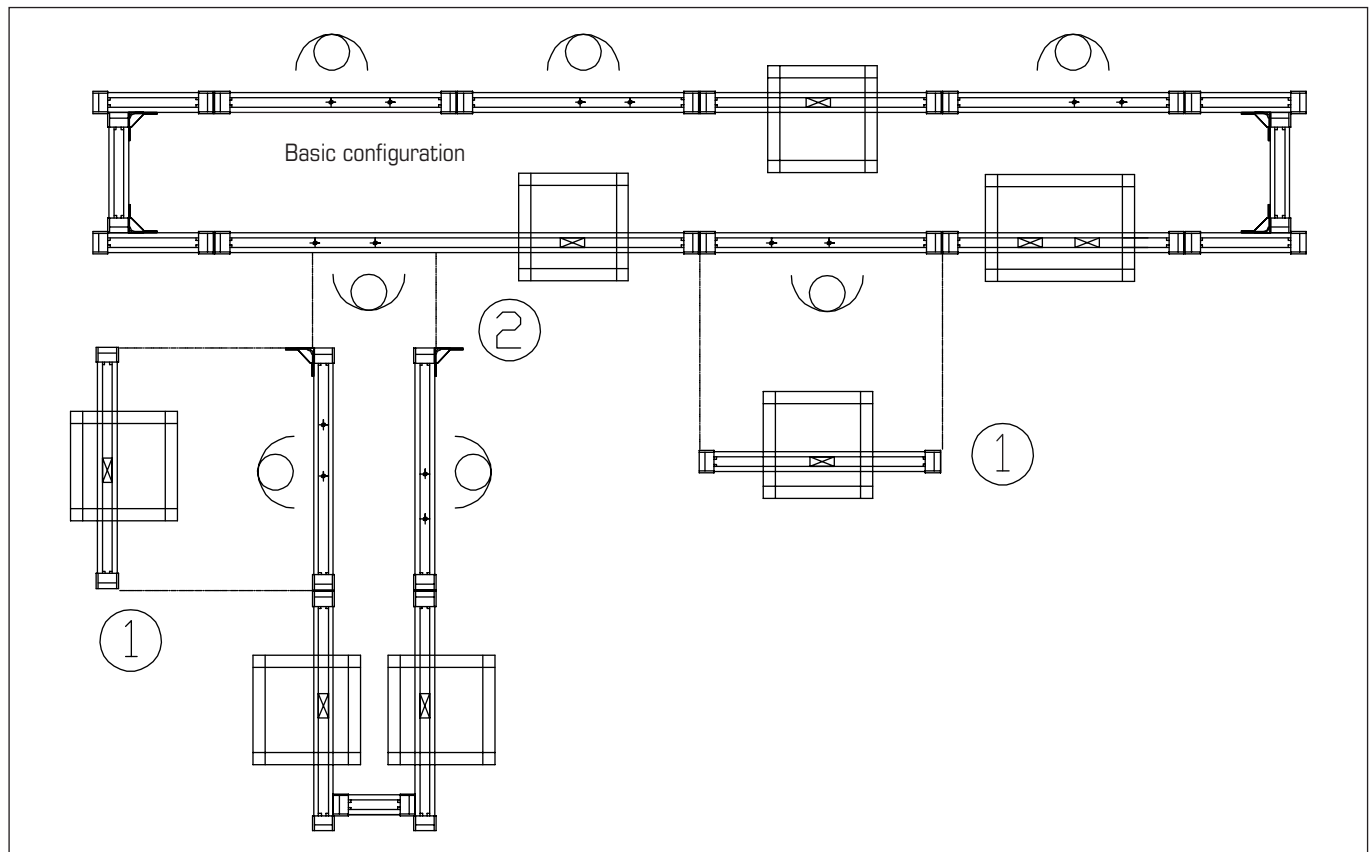



## Modular transfer systems

**elcom** is the specialist of the systems of transfer with workpiece carriers.

Various dedicated transfer systems according to weight and dimensions of the carried workpiece are available to meet your production requirements.

### Modular transfer system TLM 1000 **Page 14**

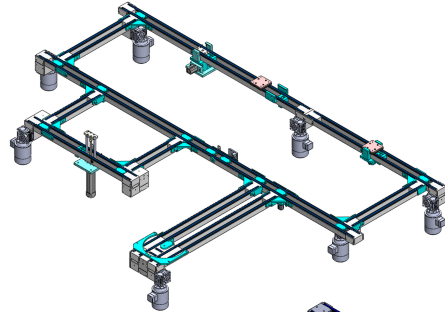

### Modular transfer system TLM 1500 **Page 62**

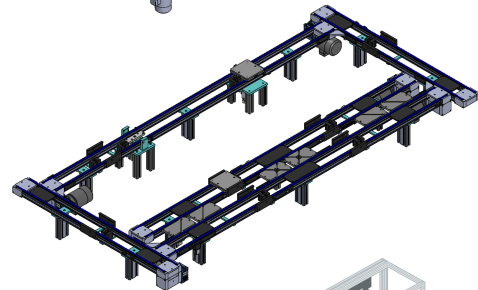

### Modular transfer system TLM 2000 **Page 102**

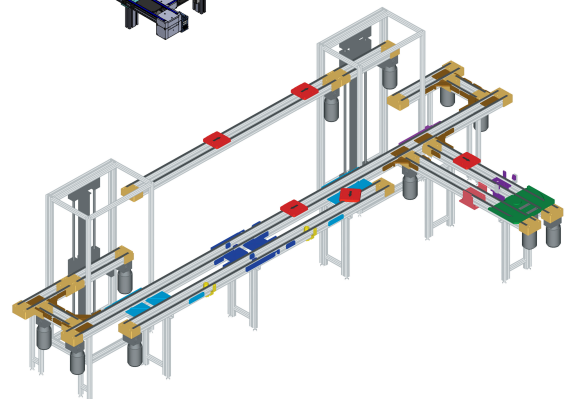

### Modular transfer system TLM 5000 **Page 182**

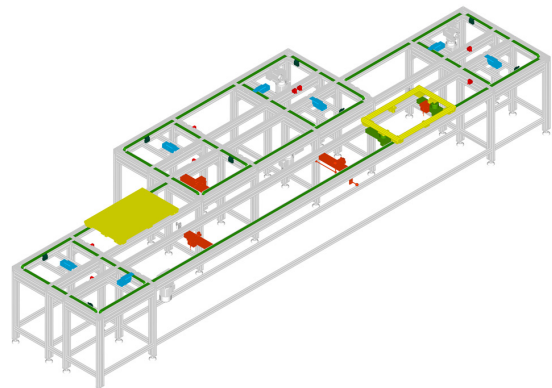

### Inflatable belt drive transfer **Page 200**

Conveying unit 24 V  
p 24

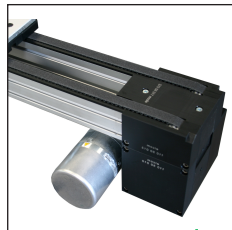

Conveying unit  
p 22

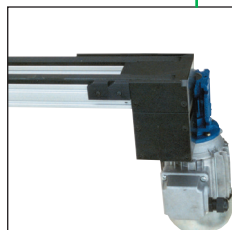

Return 180°  
p 32

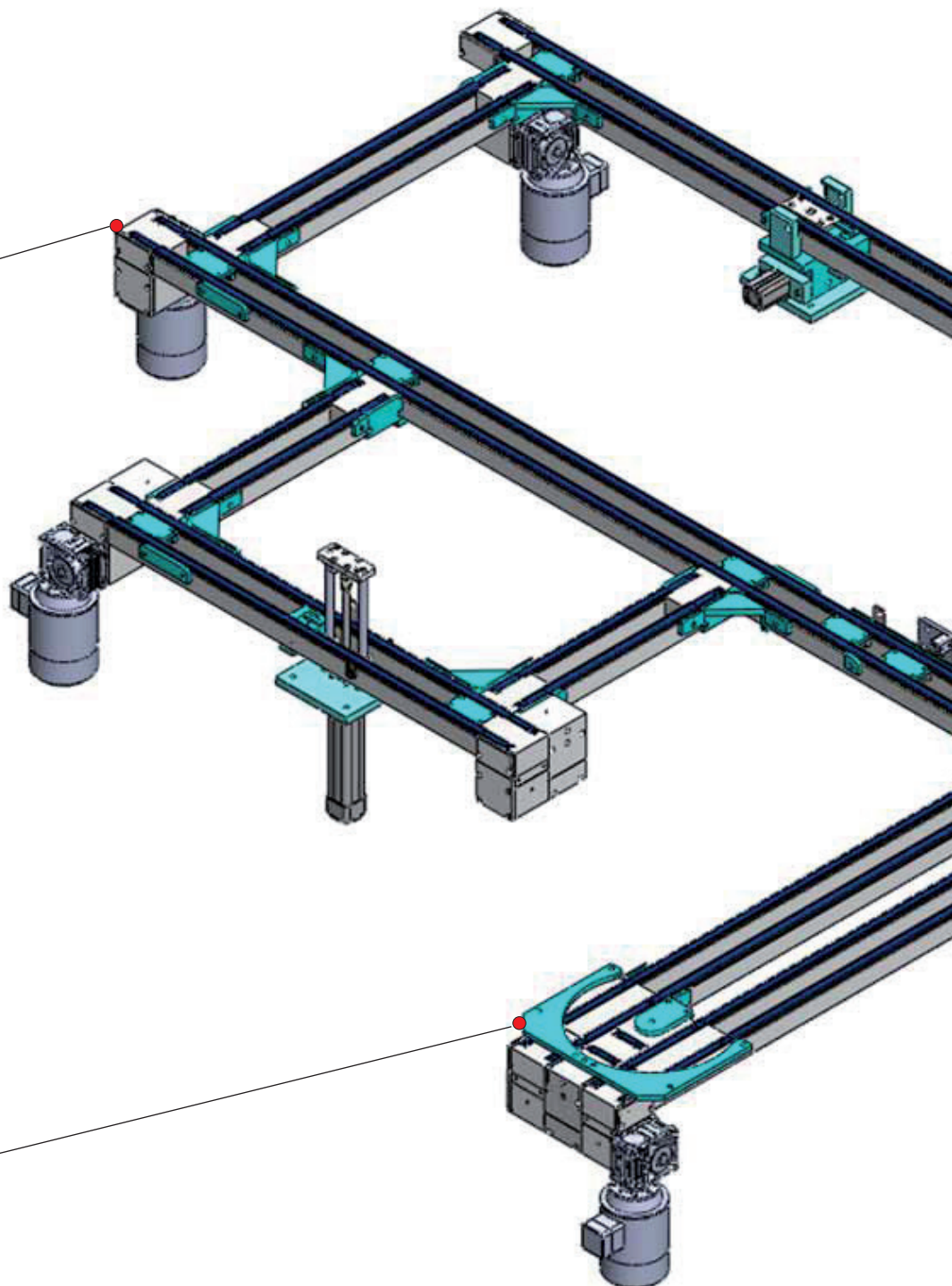
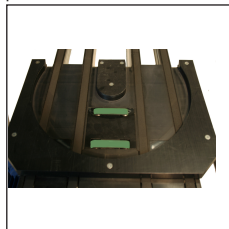

Stopper 24 V  
p 44

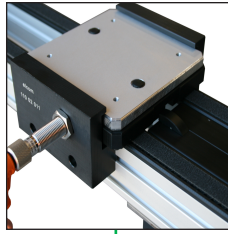

Derivation 24 V  
p 41

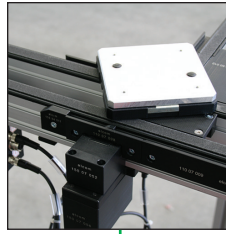

Workpiece carrier  
p 18

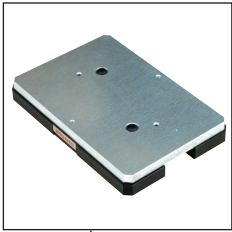

Stopper  
p 42

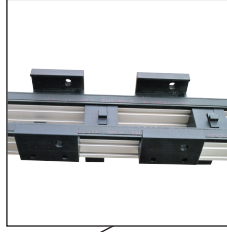

Derivation  
p 40

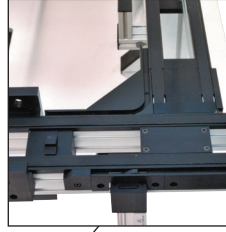

Positioning unit 24 V  
p 52

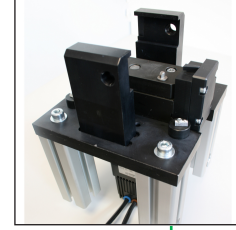

Positioning unit  
p 46

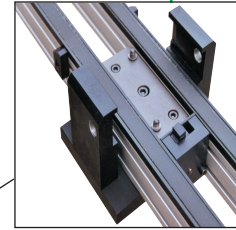

Cam  
p 38

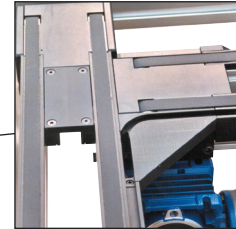

Swivelling  
p 59

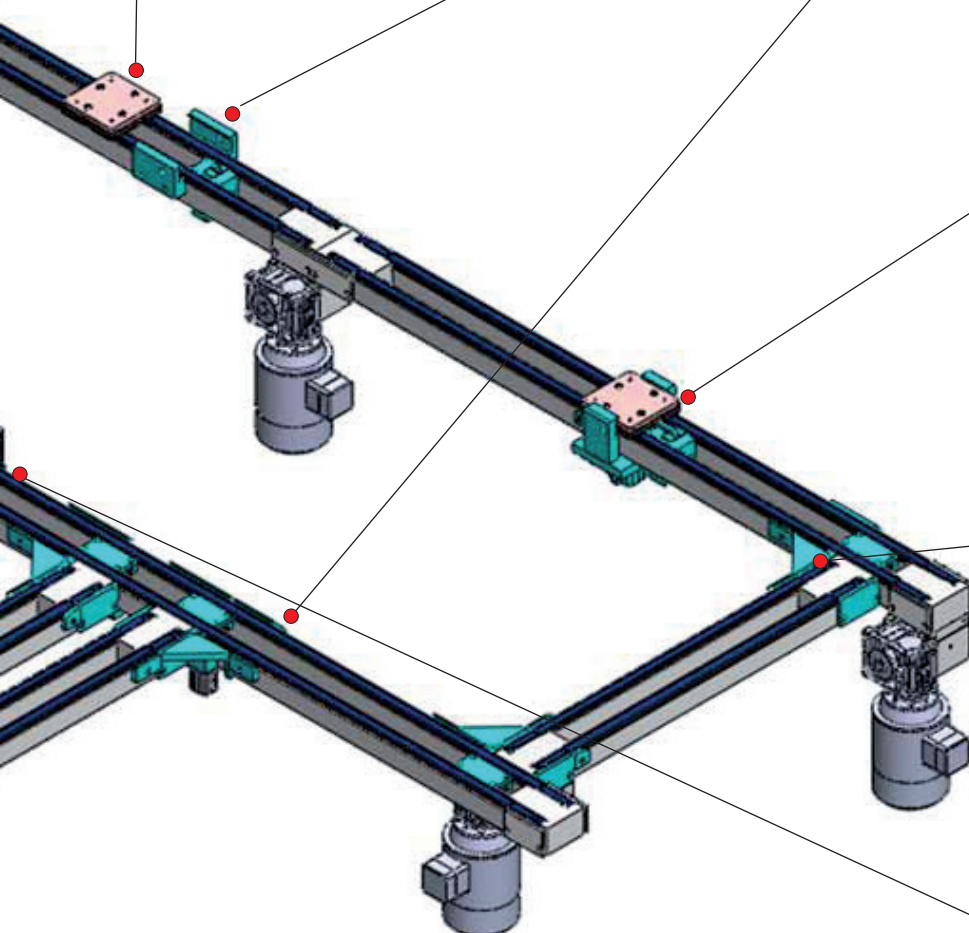
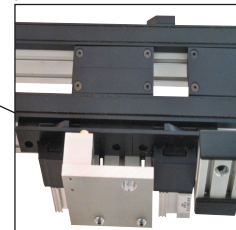

## Index TLM 1000

Designation	Page
Data.....	17
Workpiece carriers .....	18
Workpiece carriers U and M Width 100.....	20
Workpiece carriers U Width 100 Length 150.....	21
Conveying unit flat belt .....	22
Conveying unit timing belt .....	23
Conveying unit 24 V .....	24
Conveying unit flat belt Width 100.....	25
Conveying unit timing belt Width 100.....	26
Conveying unit 24 V timing belt Width 100.....	27
Multiple units .....	28
Multiple unit L Width 100.....	29
Multiple unit U Width 100.....	30
Multiple unit C Width 100.....	31
Return 180° Width 100.....	32
Return 180° Width 100 Length 150.....	33
Conveyor cut.....	34
Spacer.....	34
Caps Width 100.....	35
Straight joinings .....	35
Half junction driving unit flat belt Width 100.....	36
Half junction idling unit flat belt Width 100.....	36
Conveying unit stand Width 100.....	37
Cams 90°.....	38
Derivations Width 100.....	40
Derivations 24 V Width 100.....	41
Stoppers simple effect-double effect Width 100.....	42
Damped stopper, pneumatic Width 100.....	43
Stopper 24 V Width 100.....	44
Positioning units .....	46
Positioning units Width 100.....	48
Positioning unit, damped pneumatic stopper Width 100.....	49
Positioning units for station Width 100.....	50
Positioning unit for station, damped pneumatic stopper.....	51
Positioning unit for station 24 V Automatic stopper Width 100..	52
Heavy positioning units Width 100.....	53
Heavy positioning unit, damped pneumatic stopper Width 100.....	54
Lift positioning units Width 100.....	55
Lift positioning unit, damped pneumatic stopper Width 100.....	56
Dead man option, lift positioning units Width 100.....	57
Multi-positioning unit Width 100.....	58
90° swivelling Width 100.....	59
Sensor bracket M 12 x 100.....	60
Anti bouncing back.....	60
Positioning kit.....	61
Inductive sensor M 12 x 100.....	61
Cylinder sensors.....	61

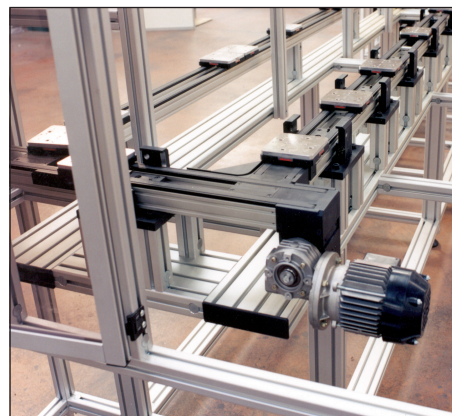

Download all CAD 3D files



on our website  
[www.elcom-automation.com/transfers](http://www.elcom-automation.com/transfers)



## Data

Workpiece carriers (mm)	105 x 105 105 x 155
Load/workpiece carrier (daN)	2
Speed (m/min) Flat belt Timing belt	10-15-20 12-16
Length of conveying unit Mini Maxi	500 3160
Maxi accumulation load per motor (daN) Flat belt Timing belt	50 25 70 35
Motor power (380 V three-phase)	0,09 KW-0,4 A

The maximum length of the conveying units is: 3160 mm.

For long spans, several elements can be butted end to end.

For important accumulations, the length of the conveying units is adapted to the load.

It is recommended to place sensors in order to control accumulation of the load.

Pneumatic cylinders must be equipped with flow rate controllers.

It is possible for long spans to be cut in order to facilitate the dismantling of the machines.

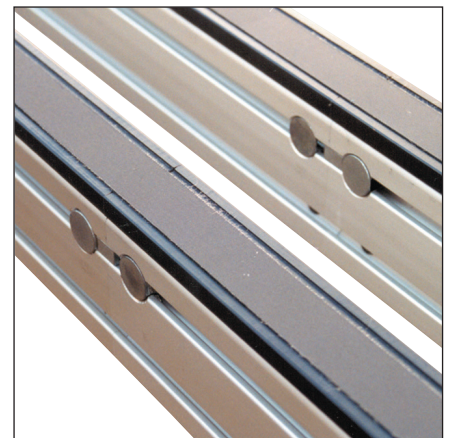

Conveyor's cut profile butted end to end



## Workpiece carriers

The workpiece carriers allow the mounting of holders which ensure an accurate positioning of the assembly during the process.

The workpiece carrier consists of two plates.

The upper aluminium plate allows the fastening of the workpieces, ensures the geometrical behaviour of workpiece carrier as well as the positioning accuracy. Machining (drillings and tappings) can be made according to the customer's wish.

Stainless steel bushes located in the aluminium plate guarantee

resistance to wear and a perfect accuracy. The PA base has an extremely low friction coefficient and lays on the conveying belts. This base hosts 4 guiding pins (specific to **elcom**) and has the necessary shape to ensure stoppers proper functioning.

Metalic bars are located on each side of the workpiece carrier in order to detect them at several workstations. The characteristics of stoppers, guiding pins with springs can be found in the next pages.

### Variable length of **elcom's** workpiece carriers and specific workpiece carriers

Standard workpiece carriers are available to install the workpieces that will be conveyed. In many cases, the surface area of workpiece carrier is not sufficient. Specific workpiece carriers can be supplied. The use of 4 guiding pins makes it possible to vary the workpiece carrier's length and to optimize cycle times. The guiding pins remain in the

position of the nearest standard workpiece carrier. So, all the standard elements such as cams are usable without modification. The following variants for a TLM 1000 system clearly show the possibilities:

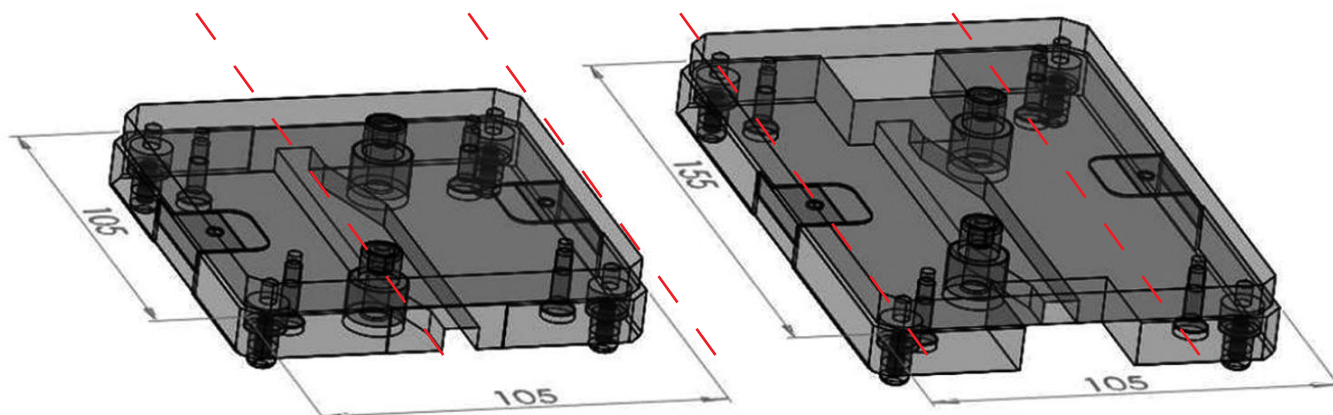

The lay-out of guide pins is identical in width. However, in the length direction, the guide pins of a 105x155 workpiece carrier have a larger gap than the 105x105 workpiece carriers. In case of use of workpiece

carriers of several dimensions on the same transfer unit, the lay-out of guiding pins must be alike.

## Workpiece carriers U and M

Workpiece carriers are used to support and position the components during the process.

The upper plate (made of aluminium) is used to fix the components and perform an accurate positioning of the workpiece carrier.

The PA base (which has a very low friction coefficient) is used to shelter the pins and to stop the workpiece carrier on the stopper.

Steel bushes located in the aluminium plate ensure a perfect accuracy and resistance against deterioration.

On each side of workpiece carrier, small metallic bars allow detection of workpiece carriers in various positions.

### Unidirectional workpiece carriers

They are perfectly compatible with a 180° swivelling.

Possibility of adding shock absorbers to limit the shock between the workpiece carriers and to reduce the noise (T).

### Multidirectional workpiece carriers

For square workpiece carriers only.

They are perfectly compatible with 90°, 180° and 270° swivellings, delivered with 2 bushes and 2 additional detection bars.

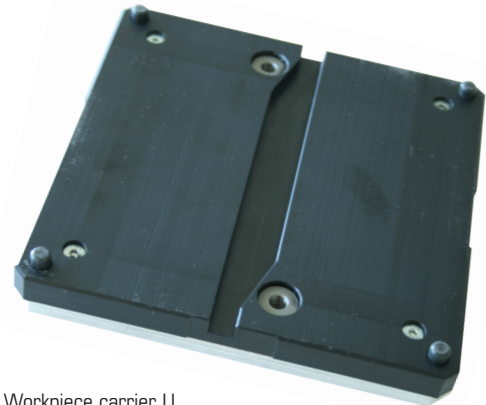

Workpiece carrier U



Workpiece carrier M

## Workpiece carriers with shock absorber T

The PA base is provided with two drills on the side in the direction of motion. Shock absorbers are inserted in these drills.

These damp the impact between two workpiece carriers and therefore reduce noise pollution.

The workpiece carrier with shock absorber T corresponds to the standard U-type workpiece carrier.



**The use of workpiece carrier with shock absorbers requires the installation of a stopper before each positioning unit.**

**This avoids the shearing of shock absorbers.**



Workpiece carrier with shock absorber

## Grinded workpiece carriers (G)

The upper aluminium plate of the grinded workpiece carrier ensures a great dimensional stability and a positioning accuracy. It has a better flatness than a standard workpiece carrier. These workpiece carriers

are recommended if large openings are carried out in the aluminium plate. Their structure correspond to the standard workpiece carriers.

## Workpiece carriers U and M Width 100

### Technical data

#### Unidirectional workpiece carrier U

- ✘ Plate Al (grinded with option G)
- ✘ Base, PA black
- ✘ 2 steel bushes
- ✘ 4 pins PA
- ✘ 4 springs
- ✘ 4 countersunk screws M4x16
- ✘ 2 detection bars
- ✘ 2 plugs

Add T at the end of reference to mention shock absorber option

Add G at the end of reference to mention grinded option

#### Multidirectional workpiece carrier M

- ✘ Plate Al
- ✘ Base, PA black
- ✘ 4 steel bushes
- ✘ 4 pins PA
- ✘ 4 springs
- ✘ 4 countersunk screws M4x16
- ✘ 4 detection bars
- ✘ 4 plugs

Add G at the end of reference to mention grinded option.



Maximum load: 2 daN

Unidirectional workpiece carrier

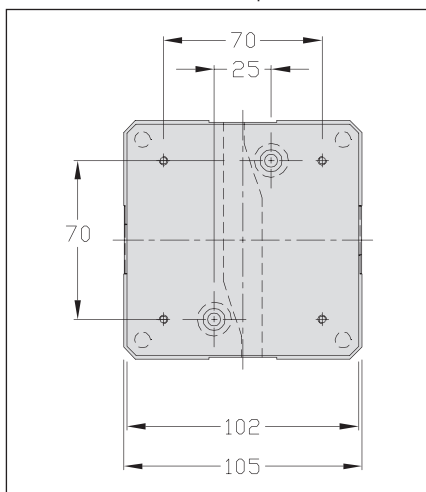

Multidirectional workpiece carrier

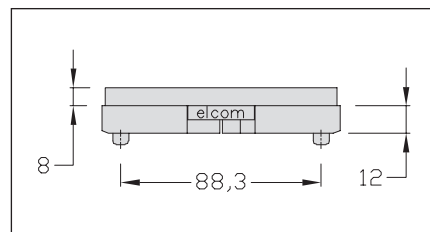
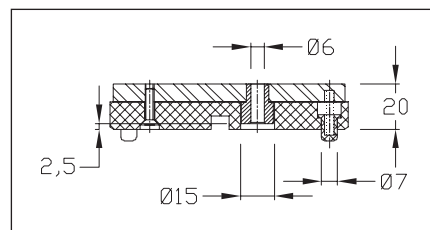
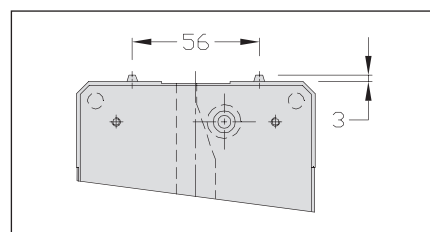
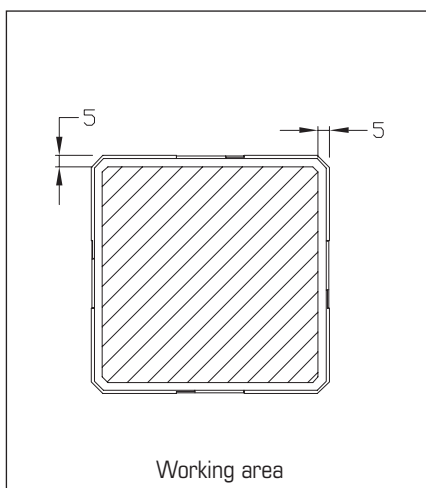
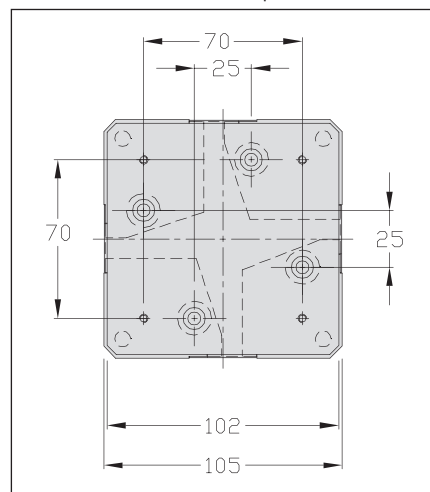

Weight: 0,41 daN

Designation / Dimensions	Order unit	Reference
Workpiece carrier U 100x100	1 pce	110.62.000
Workpiece carrier U 100x100 T	1 pce	110.62.000.T
Workpiece carrier U 100x100 grinded	1 pce	110.62.000.G
Workpiece carrier U 100x100 T grinded	1 pce	110.62.000.TG
Workpiece carrier M 100x100	1 pce	110.64.000
Workpiece carrier M 100x100 grinded	1 pce	110.64.000.G

# Workpiece carriers U Width 100 Length 150

## Technical data

- ✘ Plate Al (grinded with option G)
- ✘ Base, PA black
- ✘ 2 steel bushes
- ✘ 4 pins PA
- ✘ 4 springs
- ✘ 4 countersunk screws M4x16
- ✘ 2 detection bars
- ✘ 2 plugs

Add T at the end to mention shock absorber option.

Add G at the end of reference to mention grinded option

 Maximum load: 2 daN

Weight: 0,53 daN

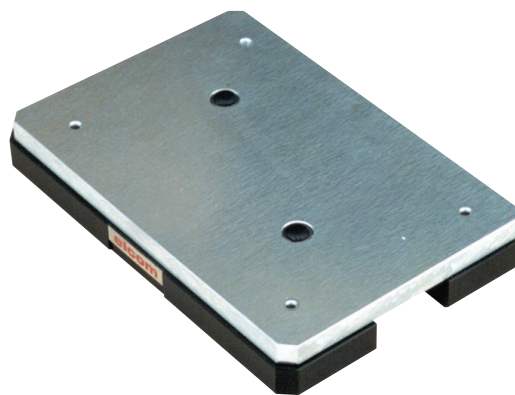
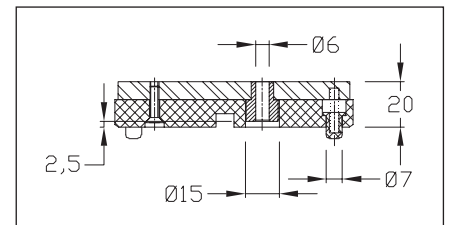
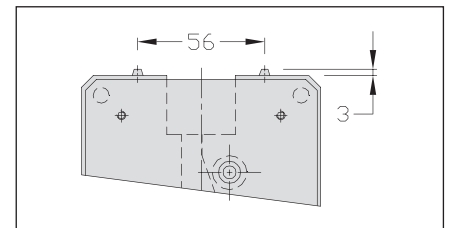
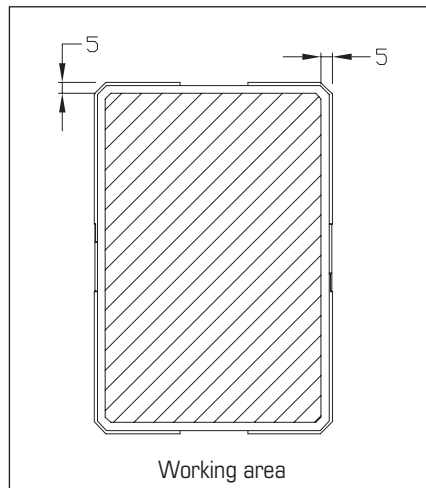
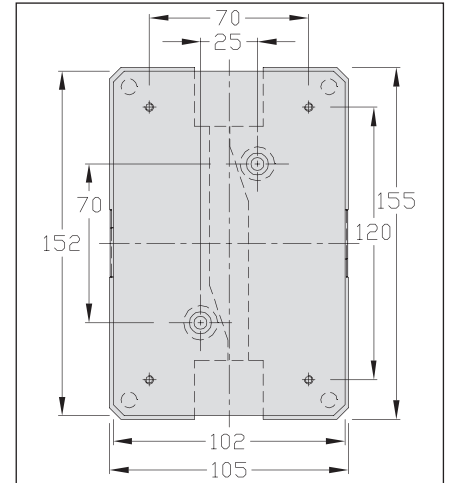
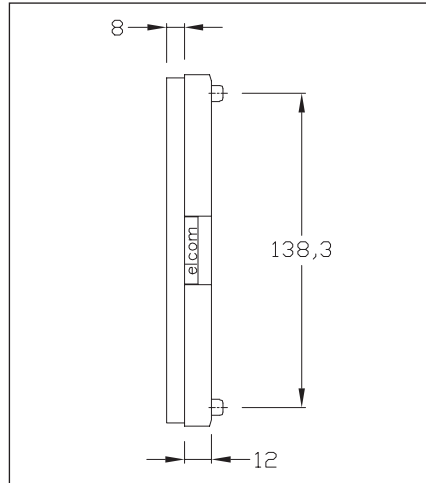

Designation / Dimensions	Order unit	Reference
Workpiece carrier U 100x150	1 pce	115.62.000
Workpiece carrier U 100x150 T	1 pce	115.62.000.T
Workpiece carrier U 100x150 grinded	1 pce	115.62.000.G
Workpiece carrier U 100x150 T grinded	1 pce	115.62.000.TG

## Conveying unit flat belt

### APPLICATIONS

Ensures the motion and accumulation of workpiece carriers 100x100 and 100x150.

The motor can be fitted either vertically or horizontally, on the right or left side.

According to the load, longer spans can be butted end to end by straight joinings.

The cuttings of the conveyors allow division of the length, making transport and installation of the lines easier.

They also allow to make important lengths for reduced loads.

Spacers have to be fitted between the profiles every meter to ensure a perfect parallelism of the profiles.

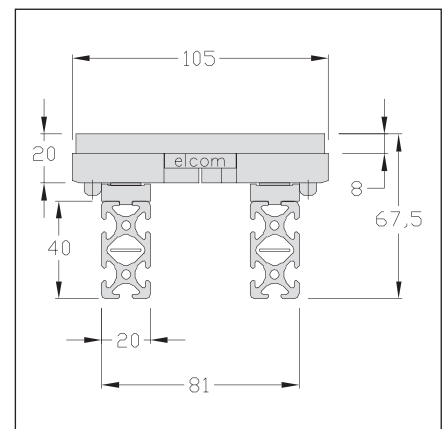



## Conveying unit timing belt

### APPLICATIONS

Ensures the motion and accumulation of workpiece carriers 100x100 and 100x150.

The motor can be fitted either vertically or horizontally, on the right or left side.

The use of timing belts enables to increase the carried load and facilitates the maintenance when changing belts. Belt guides are pressed into aluminium profile housing.

According to the load, longer spans can be joined end to end by straight joinings.

The cuttings of conveyors allow division of the lengths, making transport and installation of the lines easier. The installation is facilitated thanks to the use of timing belts.

Spacers have to be fitted between the profiles every 1 meter to ensure a perfect parallelism of the profiles.

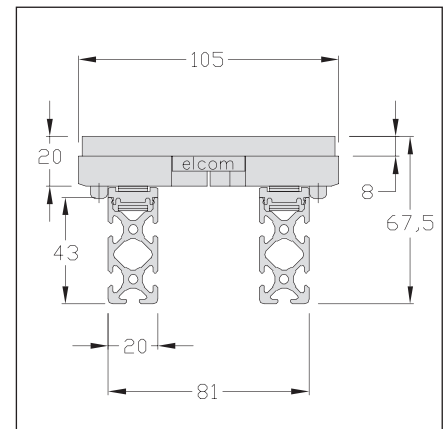

## Conveying unit 24 V timing belt

### APPLICATIONS

Moving and accumulating of workpiece carriers width 100 mm.

The use of timing belts increases the load being transported and facilitates the maintenance when changing belts. Belt guides are pressed into aluminium profile housings.

According to the load, longer spans can be

joined end to end by straight joinings. The cuttings of conveyors allow division of the lengths, making transport and installation lines easier.

The reassembly is greatly facilitated thanks to the use of timing belts.

Spacers have to be fitted between the profiles

every meter to ensure a perfect parallelism of the two profiles.

The use of a Brushless gear motor facilitates the wiring.

**elcom ITS 24 V**

# Conveying unit flat belt Width 100

## Technical data

Mini length L = 500 mm

Maxi length L = 3160 mm

For longer spans and according to the load, use several conveying units.

## Conveying unit including

- ✘ 1 idling unit
- ✘ 1 driving unit
- ✘ Speeds: 10, 15 or 20 m/min (other speeds on request)
- ✘ 1 motor 380 V three-phase  
0,09 KW I: 0,4 A

## Conveyor length

- ✘ 2 profiles 5 40x20, al anodized
- ✘ 2 belt guides, PA black
- ✘ 2 belts width 12,5 mm thickness 1 mm, welded

Maximum load /3 m: 50 daN

Maximum accumulation load /3 m: 25 daN

## Belt length in mm

L welded =

$$L_c = [(L-160) \times 2 + 490] \times 0,97$$

Weight: 8 kg + 2,07 kg /m

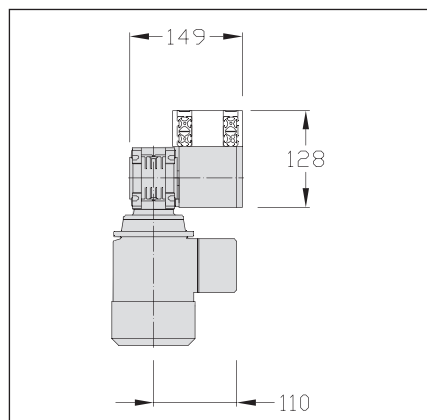
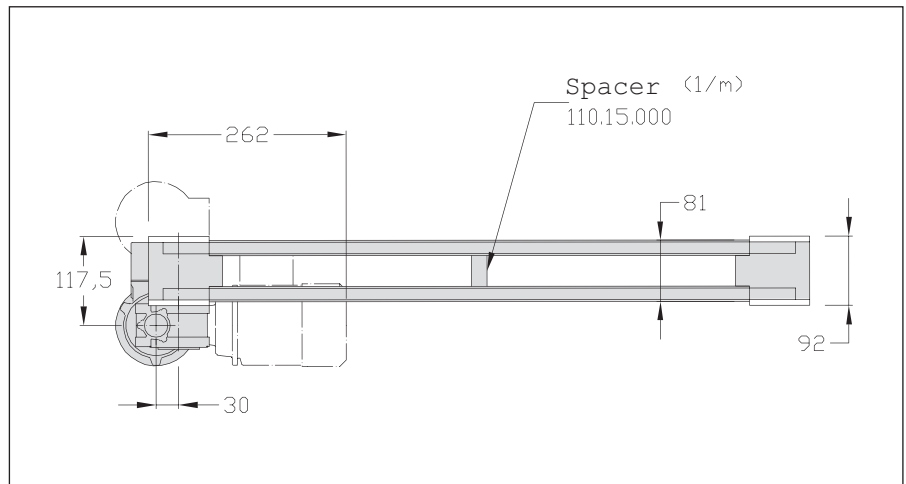
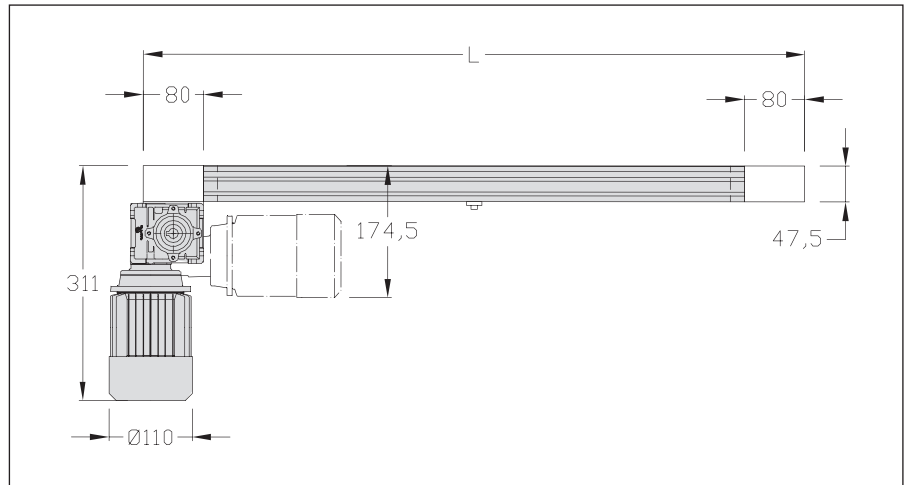

Conveying unit 100

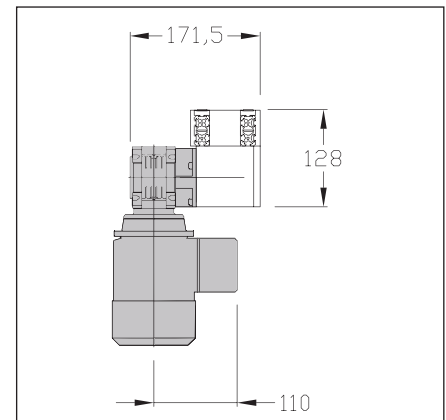

Conveying unit 100 fixed motor

Designation / Dimensions	Order unit	Reference
Conveying unit 100	1 pce	110.05.000.**
Conveying unit 100 fixed motor	1 pce	110.41.000.**
Conveying length	m	110.05.000.A

(\*\* = speed of motor m/min : 10 - 15 and 20 eg: 110.05.000.10)

## Conveying unit timing belt Width 100

### Technical data

Mini length L = 500 mm  
 Maxi length L = 3160 mm

For longer spans and according to the load,  
 use several conveying units.

### Conveying unit

- ✘ 1 idling unit
- ✘ 1 driving unit
- ✘ Speeds: 12 or 16 m/min  
 (other speeds on request)
- ✘ 1 motor 380 V three-phase  
 0,09 KW I: 0,4 A

### Conveyor length

- ✘ 2 profiles 5 43x20, al anodized
- ✘ 2 belt guides, PA black
- ✘ 2 antistatic timing belts  
 width 12 mm, 5 mm step

Maximum load /3 m: 70 daN  
 Maximum accumulation load /3 m: 35 daN

### Belt length in mm

$$L_c = [(L-160) \times 2 + 526] \times 0,9995$$

Weight: 7,5 kg + 2,07 kg /m

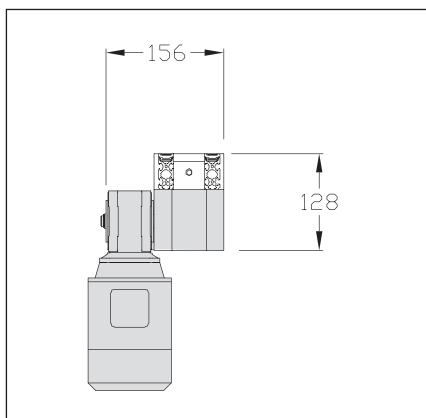
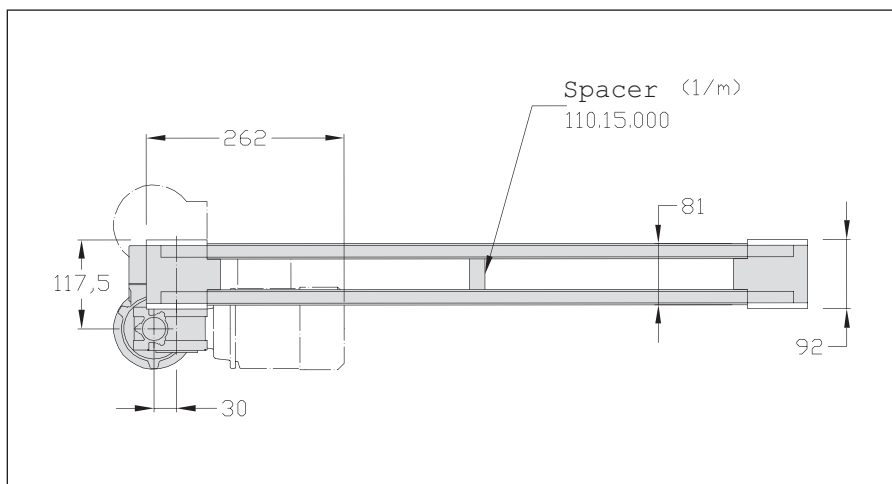
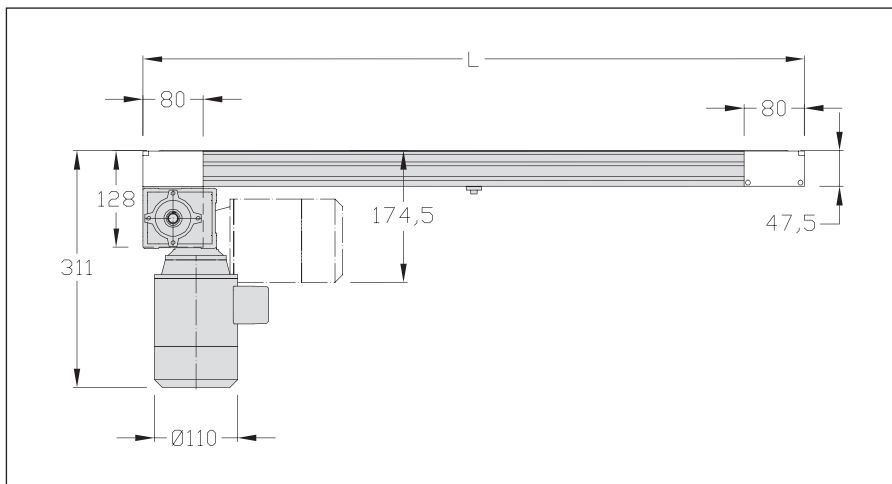

Designation / Dimensions	Order unit	Reference
Conveying unit 100 timing belt	1 pce	110.50.000.**
Conveying length	m	110.50.000.A

(\*\* = speed of motor m/min: 12 and 16 eg: 110.50.000.12)

# Conveying unit 24 V timing belt Width 100

## Technical data

Length mini L= 500 mm

Length maxi L= 3 160 mm

For longer spans and according to loads, use several conveying units.

## Conveying unit including

- ✘ 1 idling unit
- ✘ 1 driving unit  
Speed: 9 to 19 m/min,  
factory-programmed  
Possible stop in case of accumulation
- ✘ 1 gear motor 24 V  
0,09 KW  
I: minimum supply voltage 10 A

## Conveyor length

- ✘ 2 profiles 5 43x20, al anodized
- ✘ 2 belt guides, PA black
- ✘ 2 antistatic timing belts width 12 mm,  
5 mm pitch

Maximum load / 3 m: 35 daN

Maximum accumulation load / 3 m: 18 daN

Power supply: 24VDC

Supply current: 5.2 A

Control voltage: 24 VDC

Control current: 10 mA

2 control outputs, 2 status inputs.

Weight: 7 kg + 2.07 kg /m

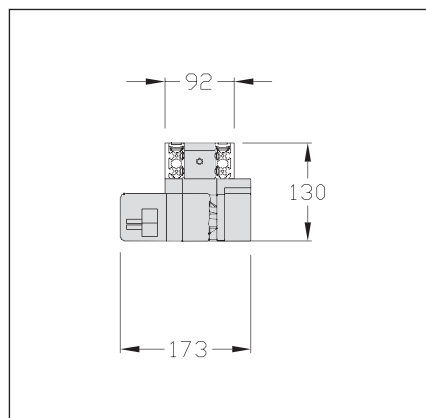
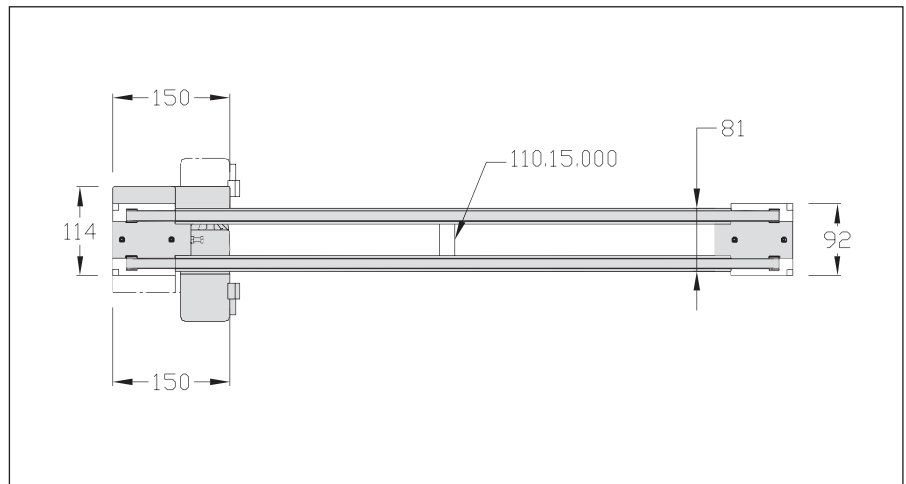
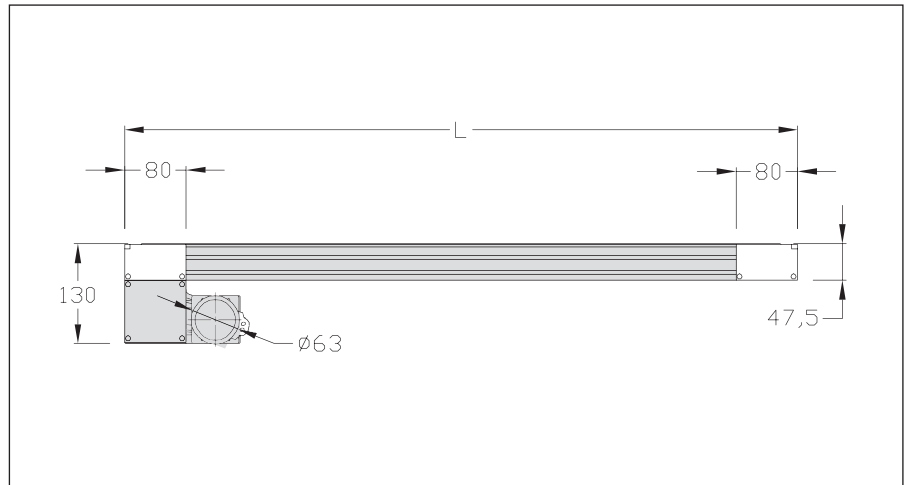

**elcom ITS 24 V**

Designation / Dimensions	Order unit	Reference
Conveying unit 24 V 100 t. belt motor Crouzet right	1 pce	110.50.000.EDC
Conveying unit 24 V 100 t. belt motor Crouzet left	1 pce	110.50.000.EGC
Conveying unit 24 V 100 t. belt motor Papst right	1 pce	110.50.000.EDP
Conveying unit 24 V 100 t. belt motor Papst left	1 pce	110.50.000.EGP
Conveying length	m	110.50.000.A



## Multiple units

### Multiple unit L 100

The use of L unit 100 enables to drive two conveyors with only one motor.  
Less electrical wiring and removal of a contactor.

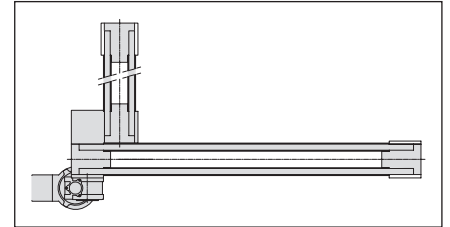

### Multiple unit U 100

The use of U unit 100 enables to drive three conveyors with only one motor and thus to make a derivation.  
Less electrical wiring and removal of two contactors.  
Space saving.

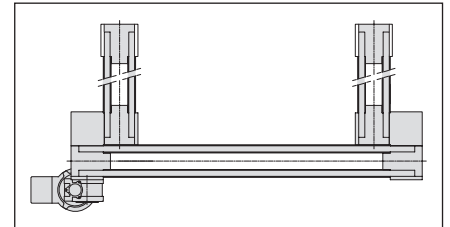

### Multiple unit C 100

The use of C unit 100 enables to drive three conveyors with only one motor and thus to make a derivation.  
Less electrical wiring and removal of two contactors.  
Space saving.

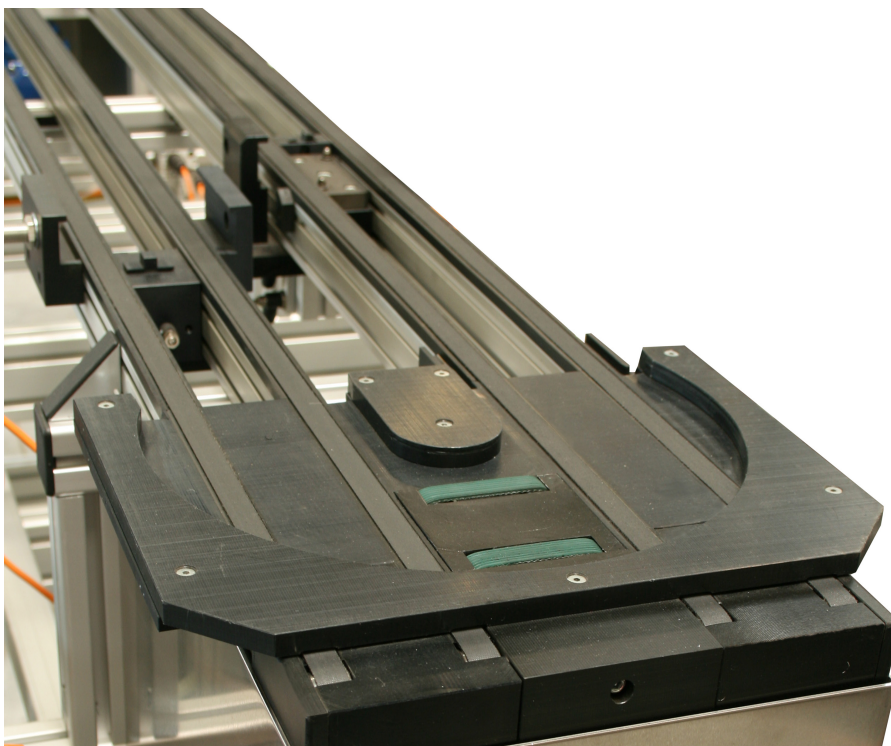
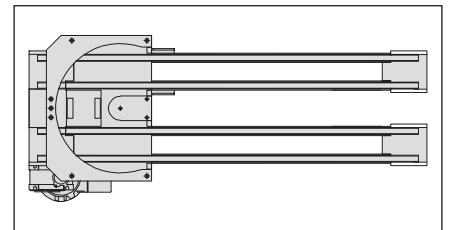

## Multiple unit L Width 100

### Technical data

- ✘ Maximum accumulation load:  
Pulling conveyor: 25 daN  
Pushing conveyor: +10 daN
- ✘ Maxi length:  
Pulling conveyor: 3 160 mm  
Pushing conveyor: 1 000 mm

### Conveying unit

- ✘ 2 idling units
- ✘ 2 driving units  
Speed: 10,15 or 20 m/min
- ✘ 1 conical torque
- ✘ 1 motor 380 V three-phase  
0,09 KW I: 0,4 A

### Conveyor length

- ✘ 2 profiles 5 40x20, al anodized
- ✘ 2 belt guides, PA black
- ✘ 2 flat belts width 12,5 mm  
thickness 1 mm

Mention lengths L1 and L2 in meter.

### Belt length in mm

$L_{\text{welded}} = [(L-160) \times 2 + 490] \times 0,97$

Weight: 13,4 kg + (L1+ L2) x 2,07 kg/m

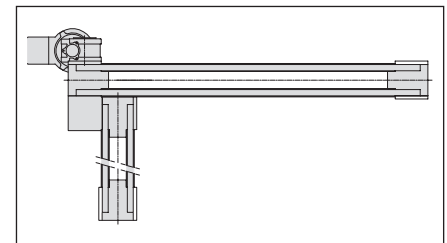
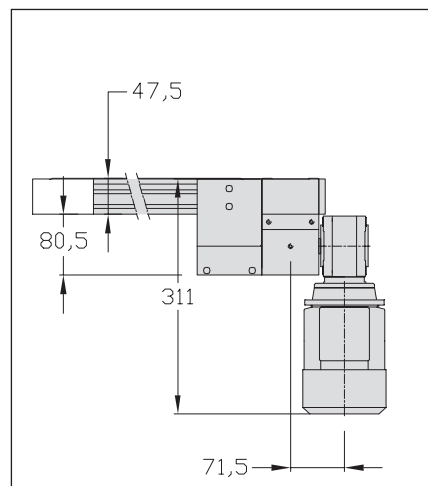
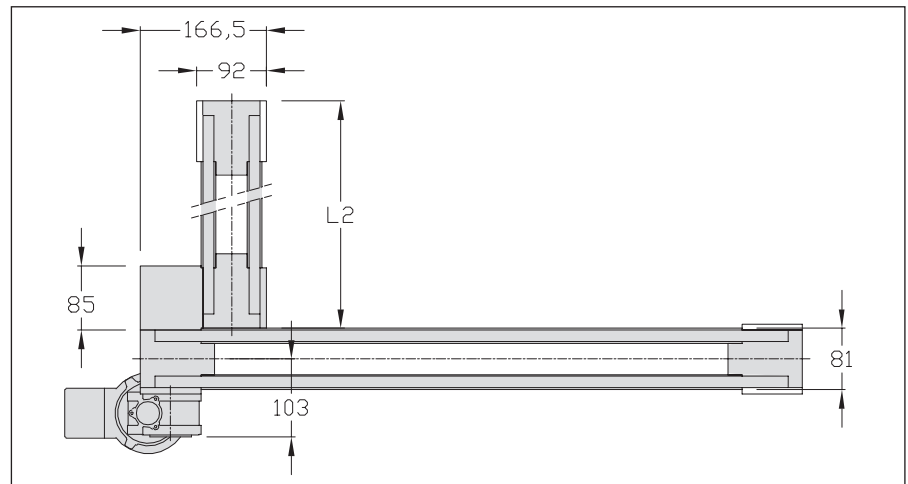
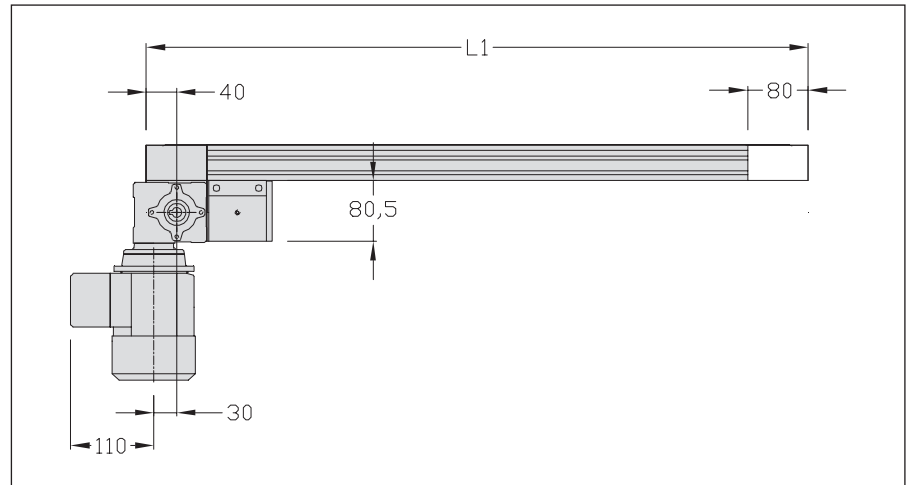

Designation / Dimensions	Order unit	Reference
Multiple unit L 100	1 pce	110.39.000.**

(\*\* = speed of motor m/min: 10, 15 or 20 eg: 110.39.000.10)

## Multiple unit U Width 100

### Technical data

- ✘ Maximum accumulation load:  
Pulling conveyor: 20 daN  
+5 daN on each perpendicular conveyor
- ✘ Maxi length:  
Pulling conveyor: 2 000 mm  
Perpendicular conveyors: 600 mm

### Conveying unit

- ✘ 2 idling units
- ✘ 4 driving units  
Speed: 10, 15 or 20 m/min
- ✘ 2 conical torques
- ✘ 1 motor 380 V three-phase  
0,09 KW I: 0,4 A

### Conveyor length

- ✘ 2 profiles 5 40x20, al anodized
- ✘ 2 belt guides, PA black
- ✘ 2 flat belts width 12,5 mm  
thickness 1 mm

Mention lengths L1, L2 and L3 in meter.

### Belt length in mm

For length L1:

$$L \text{ welded} = [(L-160) \times 2 + 678] \times 0,97$$

For lengths L2 et L3:

$$L \text{ welded} = [(L-160) \times 2 + 490] \times 0,97$$

Weight:  $18,8 + (L1 + L2 + L3) \times 2,07$  kg/m

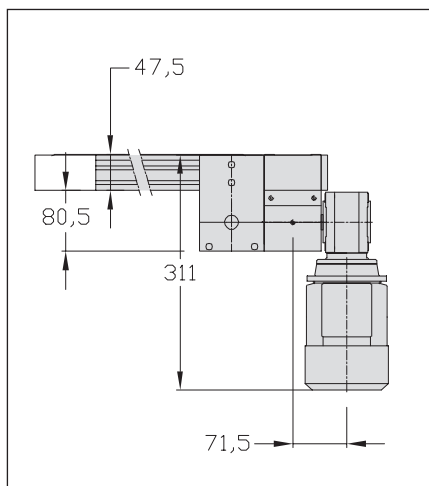
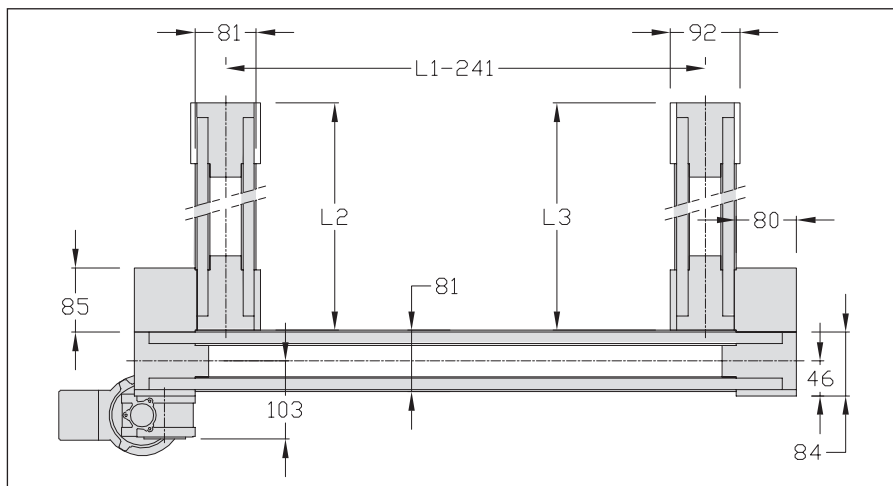
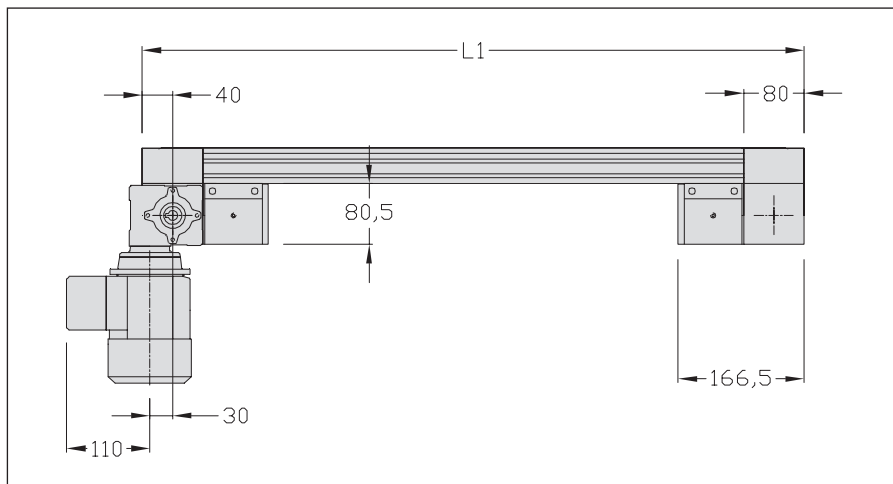

**Designation / Dimensions**

**Multiple unit U 100**

**Order unit**

**1 pce**

**Reference**

**110.38.000.\*\***

(\*\* = speed of motor m/min: 10, 15 or 20 eg: 110.38.000.10)

## Multiple unit C Width 100

### Technical data

- ✘ Maximum accumulation load:  
Pulling conveyor: 20 daN  
Pushing conveyor: +10 daN
- ✘ Maxi length: 2 000 mm

### Conveying unit

- ✘ 2 idling units
- ✘ 2 driving units  
speed: 10, 15 or 20 m/min
- ✘ 1 180° swivelling 100
- ✘ 2 conical torques
- ✘ 1 motor 380 V three-phase  
0,09 KW I: 0,4 A

### Conveyor length

- ✘ 2 profiles 5 40x20, al anodized
- ✘ 2 belt guides, PA black
- ✘ 2 flat belts width 12,5 mm  
thickness 1 mm

Mention length L in meter.

### Belt length in mm

$L_{\text{welded}} = [(L-160) \times 2 + 490] \times 0,97$

⚠ Minimum load on workpiece carrier:  
0,3 daN

⚠ Do not accumulate in the unit

Weight:  $20,2 + L \times 4,14$  kg/m

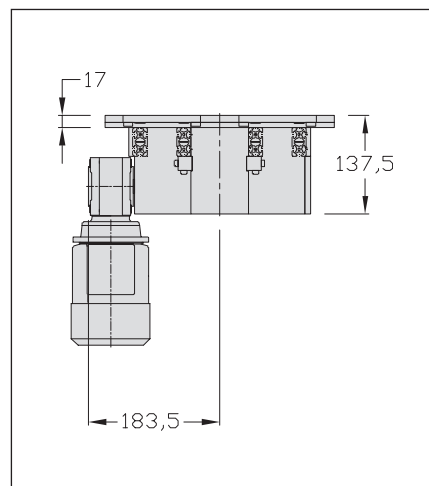
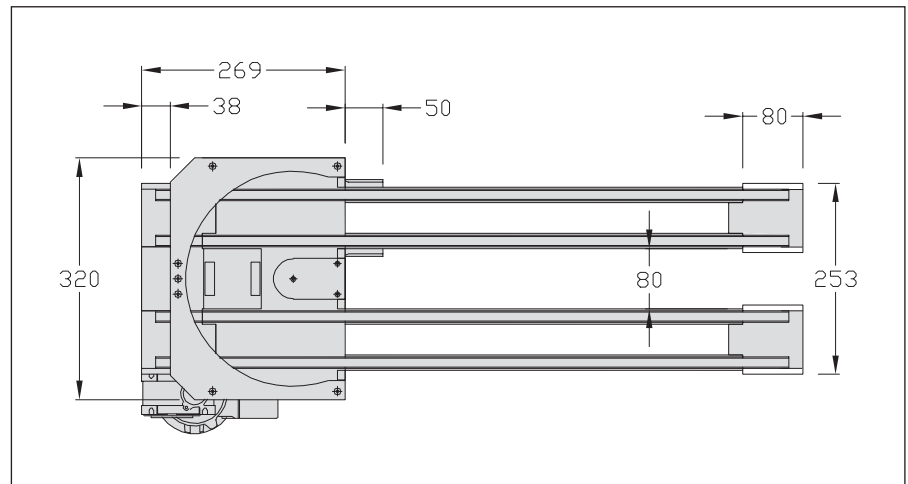
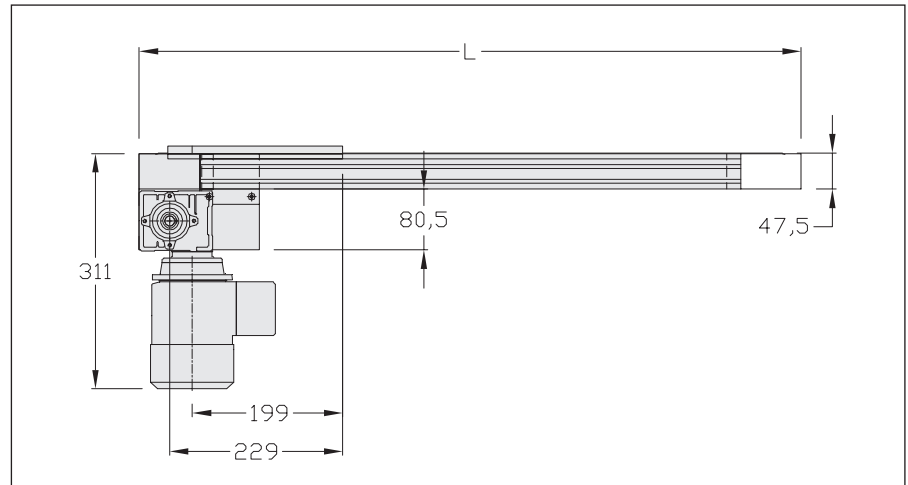

**Designation / Dimensions**

**Multiple unit C 100**

**Order unit**

**1 pce**

**Reference**

**110.35.000.\*\***

(\*\* = speed of motor m/min: 10, 15 or 20 eg: 110.35.000.10)

## Return 180° Width 100 Length 100

### APPLICATIONS

Allows the return of the workpiece carrier on a parallel conveyor with a reduced space between the two conveyors.

The workpiece carrier is conveyed always keeping the same side towards the outside of the line.

For square workpiece carriers only.

2 parallel belts driven by a bevel gear pair on a conveyor unit

### Technical data

- x Aluminium housing
- x Conical torque

(No additional motor)



Minimum load on the workpiece carrier: 0,3 daN



Do not accumulate workpiece carriers in the returns.

Weight: 8 kg

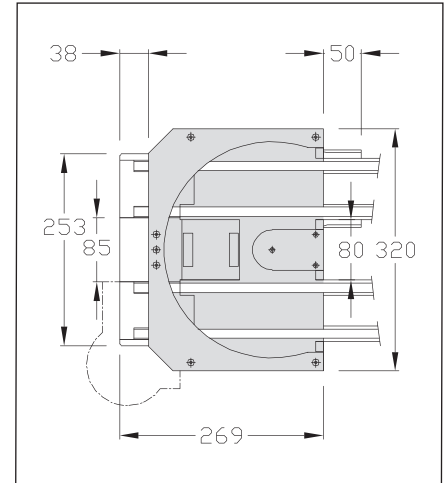
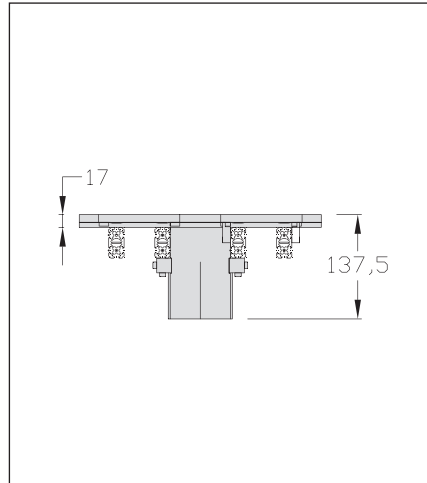

**Designation / Dimensions**

**Return 180° 100**

**Order unit**

**1 pce**

**Reference**

**110.34.000**



# Return 180° Width 100 Length 150

## APPLICATIONS

Allows the return of the workpiece carrier on a parallel conveyor with a reduced space between the two conveyors.

The workpiece carrier is conveyed always keeping the same side towards the outside of the line.

For rectangular workpiece carriers 100x150 only.

2 parallel belts driven by a bevel gear pair on a conveyor unit

## Technical data

- ✘ Aluminium housing
- ✘ Conical torque

(No additional motor)

- ⚠ Minimum load on the workpiece carrier: 0,3 daN
- ⚠ Do not accumulate workpiece carriers in the returns

Weight: 8,3 kg

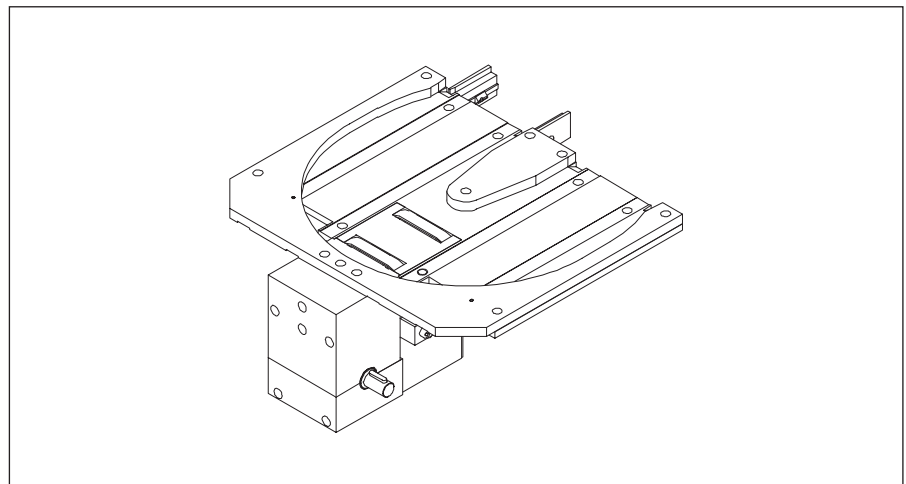
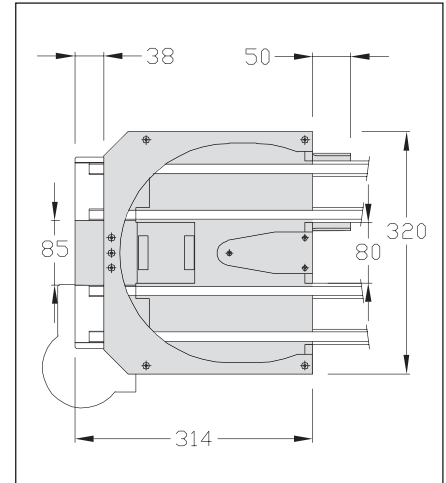
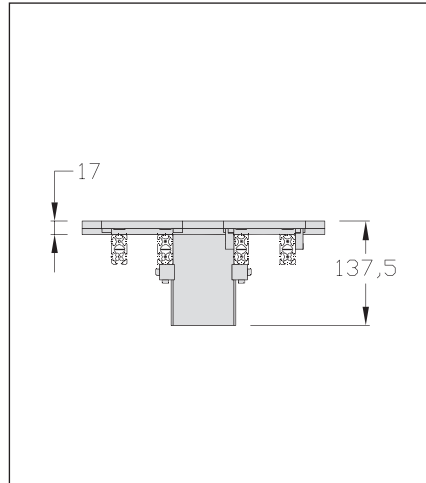

**Designation / Dimensions**

**Return 180° 100x150**

**Order unit**

**1 pce**

**Reference**

**115.34.000**

## Conveyor cut

### APPLICATIONS

The cut allows division of conveyor lengths to make the transport and installation easier.

It also enables the making of important lengths when the load is limited.

#### Technical data

**x** Maximum length: 5 m

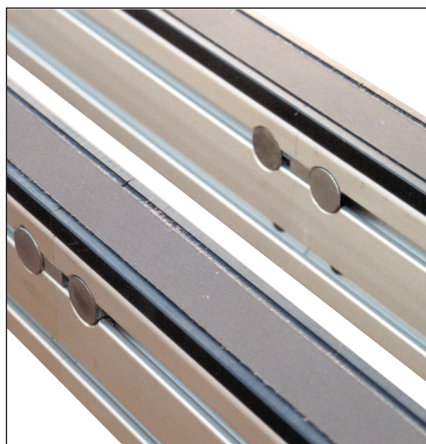

Lengths	Data	
	Maximum load daN	Maximum load in accumulation daN Flat belt
3,16 m	50	25
4 m	40	20
5 m	30	15

Designation / Dimensions	Order unit	Reference
Conveyor cut 100	1 cut	110.05.000B

## Spacer Width 100

### APPLICATIONS

Spacers have to be fitted every 1 meter to ensure a perfect parallelism of profiles

#### Technical data

**x** 1 aluminium part + fastening parts

Weight: 0,042 kg

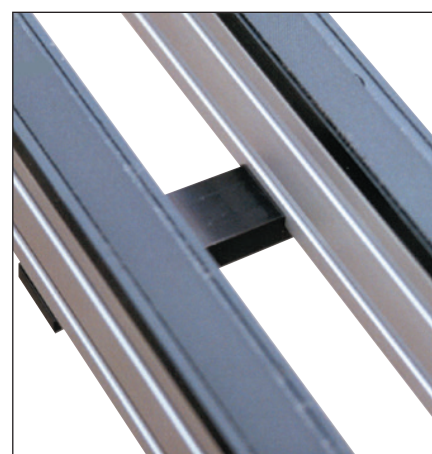
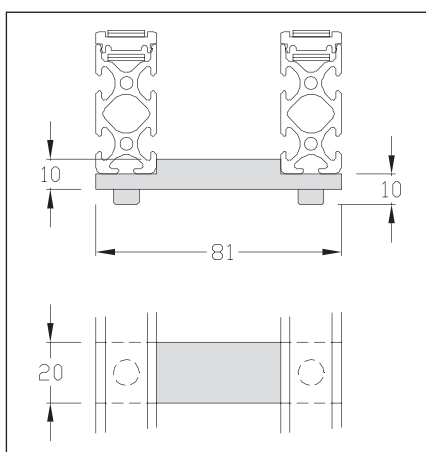

Designation / Dimensions	Order unit	Reference
Spacer 100	1 pce	110.15.000

## Caps Width 100

### APPLICATIONS

Allow to protect the direct driving and the idling unit. When using a cam, the opposite cap is delivered with the cam set.

#### Technical data

##### Cap 100 flat belt

- ✗ 2 parts, PE black
- + fastening parts

##### Cap for motorization 100 timing belt

- ✗ 1 part and 1 symmetrical part, PA black
- + fastening parts

##### Cap for idling unit 100 timing belt

- ✗ 1 part and 1 symmetrical part, PA black
- + fastening parts

Weight: 0,07 kg

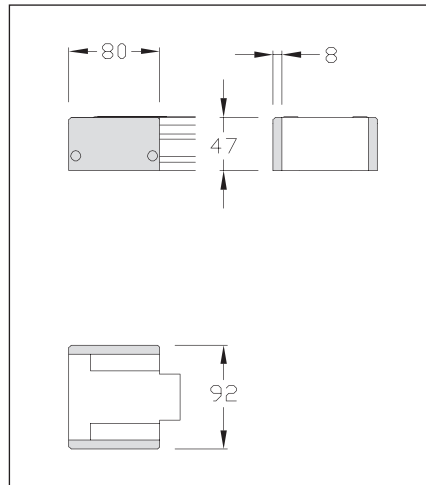

Flat belt

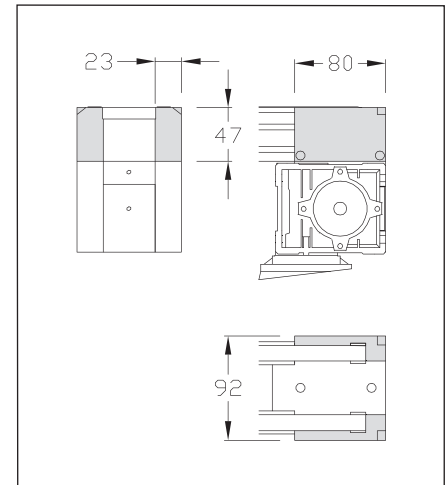

Timing belt

Designation / Dimensions	Order unit	Reference
Cap for motorization and idling unit 100	1 set	110.05.100
Cap for motorization 100 timing belt	1 set	110.50.100
Cap for idling unit 100 timing belt	1 set	110.50.200

## Straight joinings Width 100

### APPLICATIONS

Allow to join end to end two conveying units.

#### Technical data

- ✗ Guide PA black
- ✗ Joining set aluminium

Weight: 0,16 kg

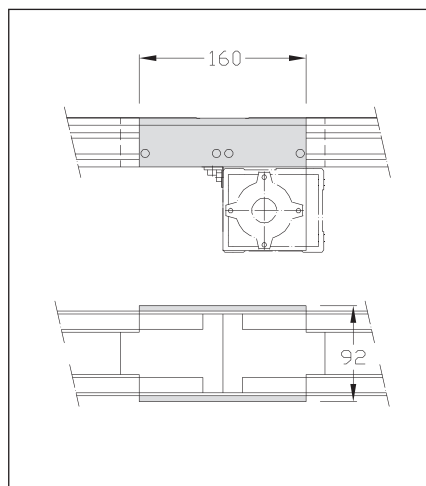

Flat belt

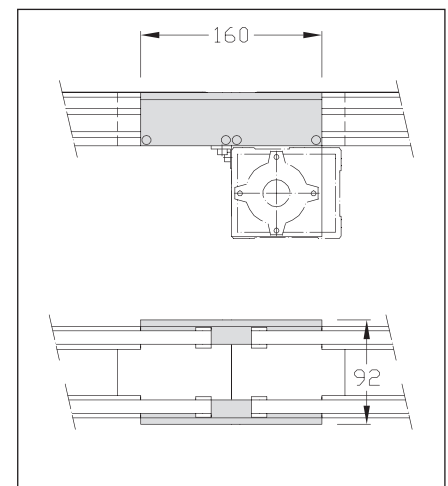

Timing belt

Designation / Dimensions	Order unit	Reference
Straight joining 100	1 set	110.18.000
Straight joining 100 timing belt	1 set	110.52.000

## Half junction driving unit flat belt Width 100

### APPLICATIONS

It allows a workpiece carrier to go out of the transfer line on the driving side.

#### Technical data

- ✘ 2 parts, PE black
- ✘ Fastening parts

Weight: 0,08 kg

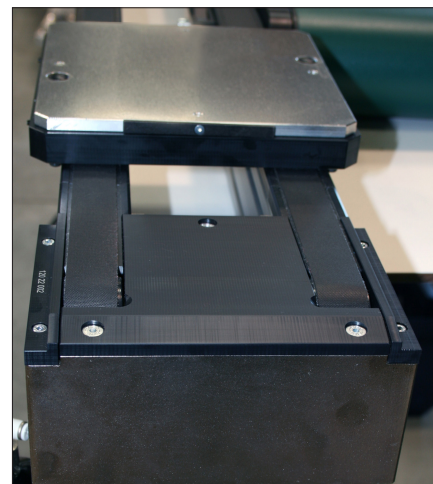
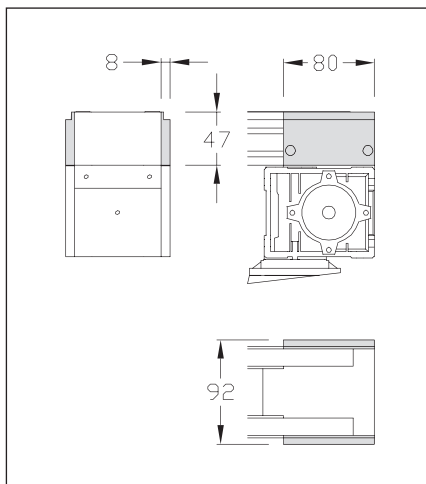

Designation / Dimensions	Order unit	Reference
Half junction driving unit flat belt 100	1 set	110.40.100

## Half junction idling unit flat belt Width 100

### APPLICATIONS

It allows a workpiece carrier to go out of the transfer line on the idling side.

#### Technical data

- ✘ 2 parts, PE black
- ✘ Fastening parts

Weight: 0,08 kg

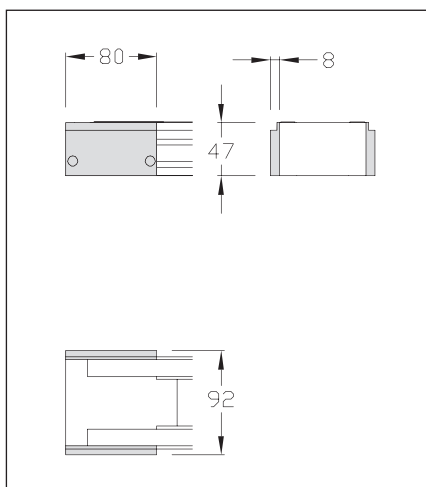

Designation / Dimensions	Order unit	Reference
Half junction idling unit flat belt 100	1 set	110.40.200

# Conveying unit stand Width 100

## APPLICATIONS

Support to fit conveying units on table or frame.

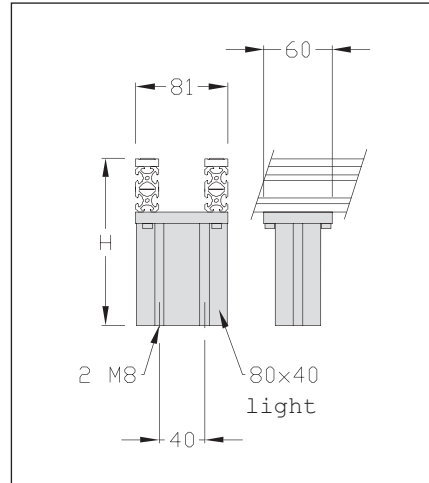

Designation / Dimensions	Order unit	Reference
Conveying unit stand 100	1 set	110.16.000



Example of an application of conveying unit stands



## Cams 90°

### APPLICATIONS

**Cams ED, EG, SD, SG** allow a perpendicular transfer of workpiece carriers from one conveying unit to the other without automatism. The principle is the same for conveying units with flat belts and timing belts. It's not possible as standard features, to set a cam between two different units.

The workpiece carrier is guided by the two inner pins, the outside pins are retracted. They are also used for derivations. For a good operating, the workpiece carrier which is coming in the cam mustn't be pushed by other workpiece carriers.

 **Do not accumulate the workpiece carriers in the cams.**

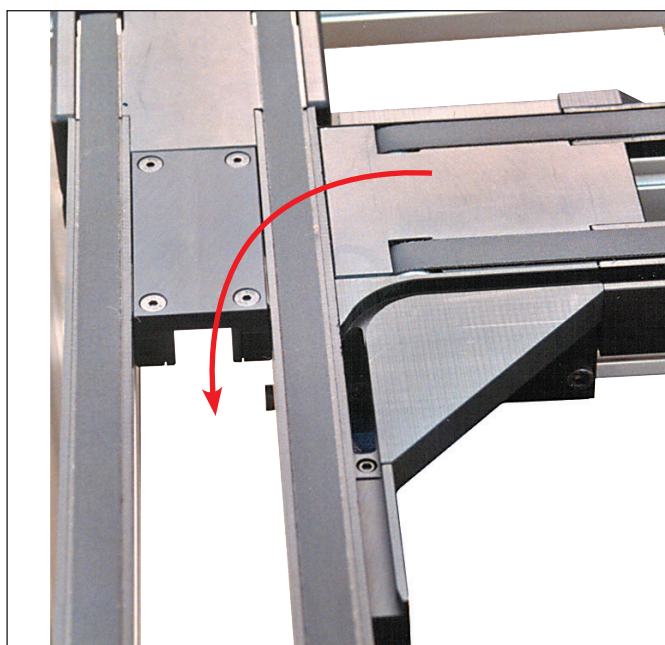

Cam 90° EG

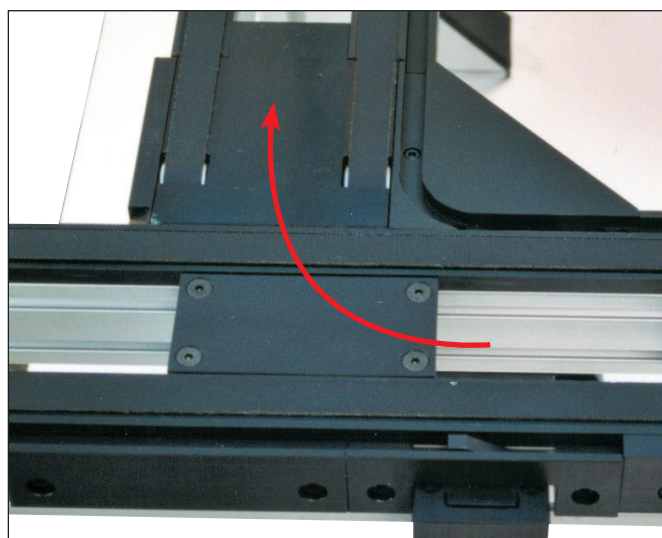

Cam 90° SD

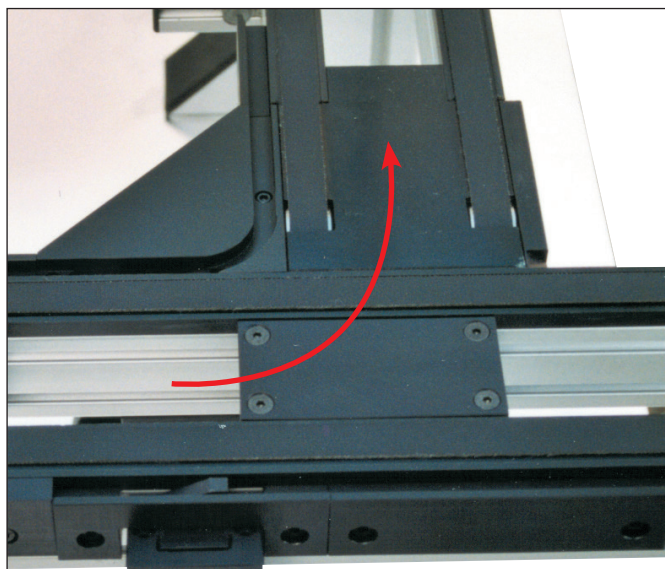

Cam 90° SG

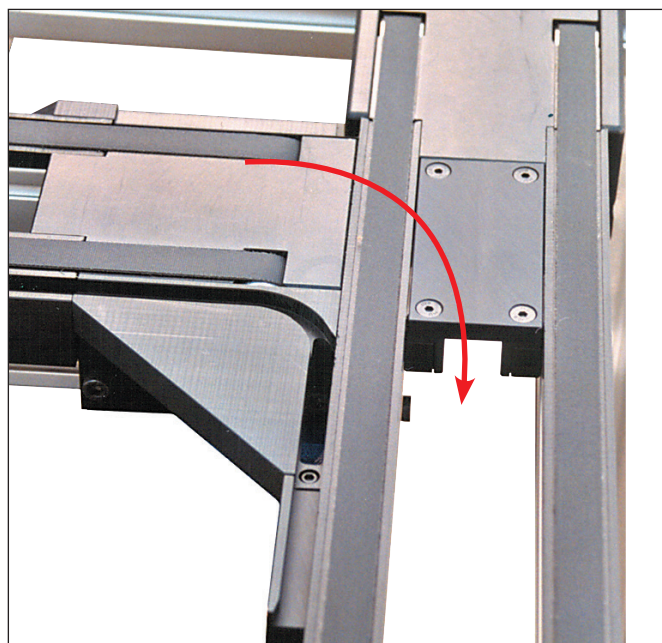

Cam 90° ED

## Cams 90° Width 100

### Technical data

- ✗ Guiding cam and pin retracting plates, PA black
- ✗ Fastening parts
- ✗ Joining parts
- ✗ A cap for motorization or for idling unit

Various cams according to the length of workpiece carriers.

$L_p$  = length of workpiece carriers

If a selection is necessary (derivation or not), add the derivation set.

Weight:

Cam 90° 100: 0,42 kg

Cam 90° 150: 0,45 kg

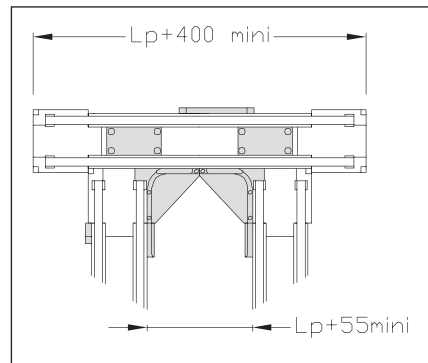
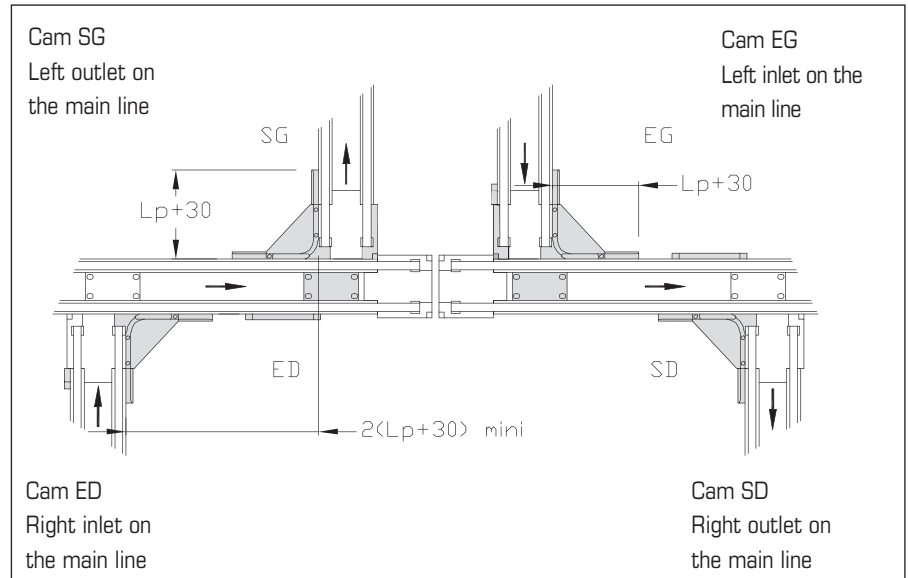

Designation / Dimensions	Order unit	Reference
Cam 90° ED 100	1 set	110.04.100
Cam 90° EG 100	1 set	110.04.200
Cam 90° SD 100	1 set	110.04.300
Cam 90° SG 100	1 set	110.04.400
Cam 90° ED 150	1 set	115.04.100
Cam 90° EG 150	1 set	115.04.200
Cam 90° SD 150	1 set	115.04.300
Cam 90° SG 150	1 set	115.04.400
Cam 90° ED 100 timing belt	1 set	110.53.100
Cam 90° EG 100 timing belt	1 set	110.53.200
Cam 90° SD 100 timing belt	1 set	110.53.300
Cam 90° SG 100 timing belt	1 set	110.53.400
Cam 90° ED 150 timing belt	1 set	115.53.100
Cam 90° EG 150 timing belt	1 set	115.53.200
Cam 90° SD 150 timing belt	1 set	115.53.300
Cam 90° SG 150 timing belt	1 set	115.53.400

## Derivations Width 100

### APPLICATIONS

Derivations have to be used with a cam. They allow derivation or not of the workpiece carrier by retraction of the pins on one side or the other of the conveyor.

The two cylinders are controlled by only one solenoid valve.

#### Technical data

- ✗ 2 plates Al
- ✗ 2 nuts 5 St M4
- ✗ 2 screws M4x10
- ✗ Body, levers and guides PA
- ✗ 2 cylinders  $\varnothing$  16-5 M5, detectable positions



Cams are not included (to be ordered separately).

Weight: 0,4 kg

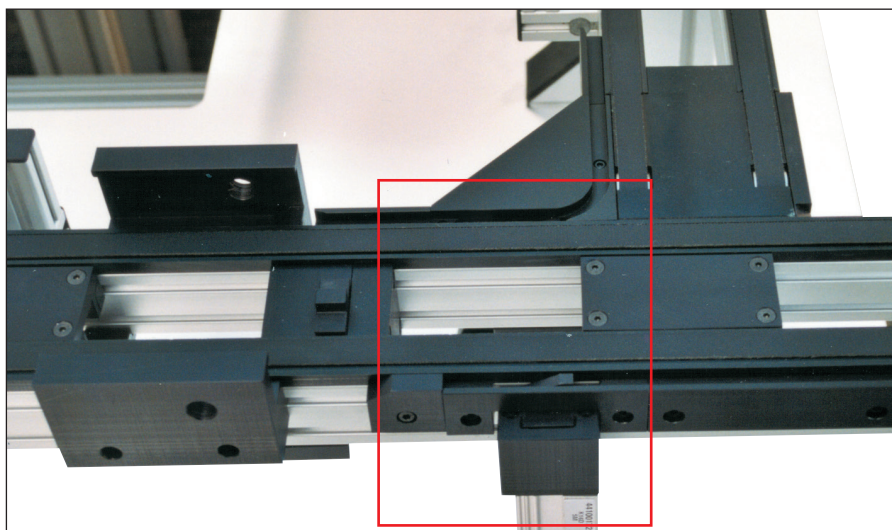
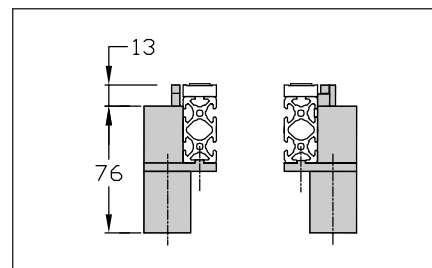
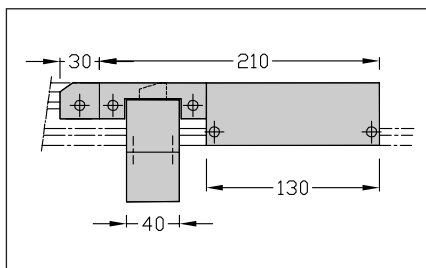
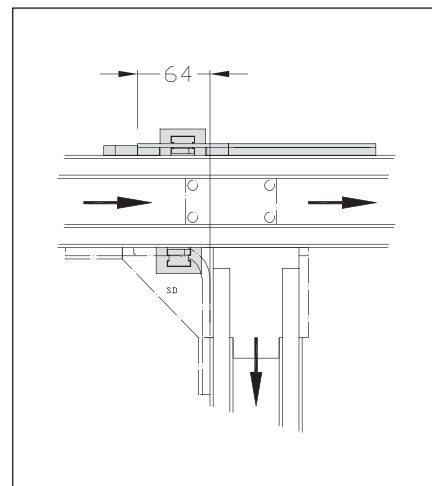
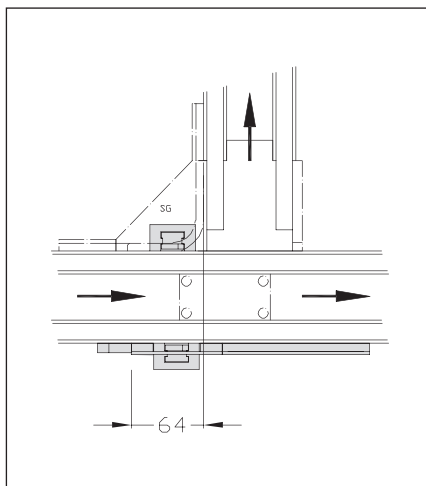

Designation / Dimensions	Order unit	Reference
Derivation 100 SD	1 set	110.07.000
Derivation 100 SG	1 set	110.13.000

## Derivations 24 V Width 100

### APPLICATIONS

Necessarily combined with a cam, they allow the deviation of workpiece carriers, or not, by retracting the pins on one side or the other of the conveyor.

2 Brushless gear motors controlled by a control box ensure the movement.

A single output for logic controller is necessary. Cams are not included.

Control module 24v output: automation, bus module, splitter,...

Standard connectors M12.

An extension for connection M8 male/female 3 pins between the motor and the control box is required.

### Technical data

Complete set including:

- ✘ 2 plates Al
- ✘ 2 nuts 5 St M4
- ✘ 2 screws M4x10
- ✘ Body, levers and guides PA
- ✘ 2 gear motors 24 V

 Cams are not included (must be ordered separately).

Supply voltage of the control box:

24 volt +/- 15%

Maximum power supply: 1,6 A

Control voltage: 24 volt +/- 10 %

Control current: 5 mA maxi

Weight: 0.8 kg

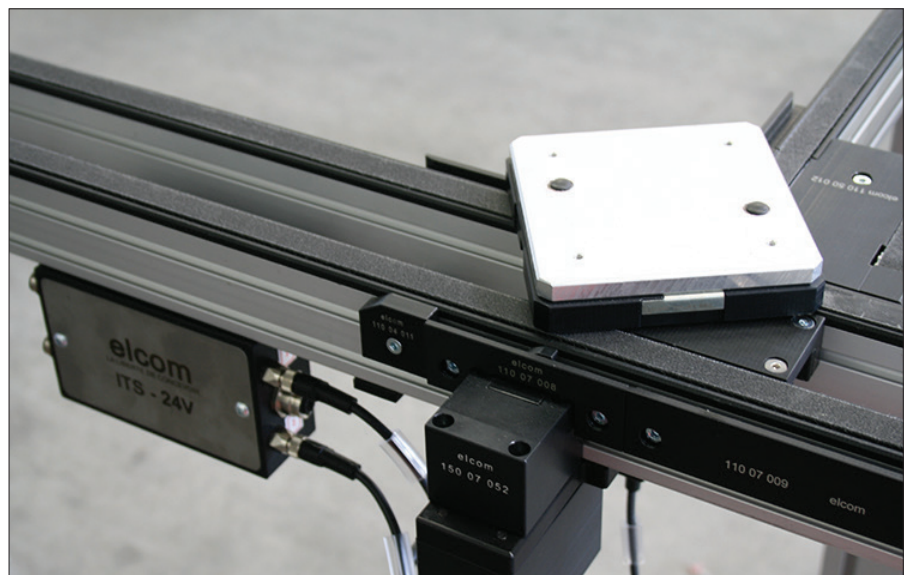
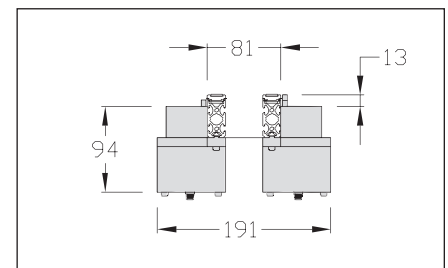
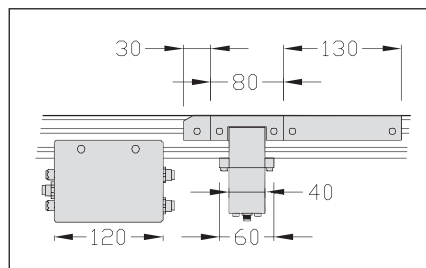
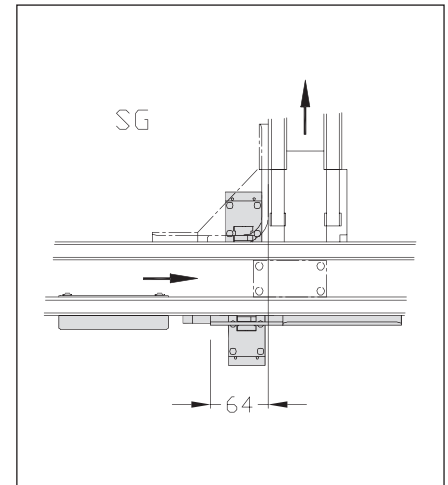
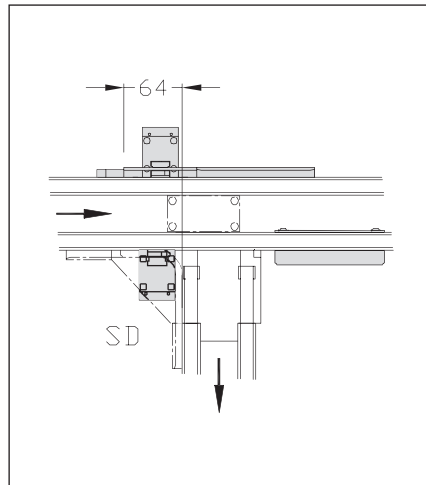

elcom ITS 24 V

Designation / Dimensions	Order unit	Reference
Derivation 24 V 100 SD	1 kit	110.07.000.E
Derivation 24 V 100 SG	1 kit	110.13.000.E



## Stoppers simple effect - double effect Width 100

### APPLICATIONS

Stopping workpiece carriers during processing requiring no accuracy.

Stopping the workpiece carriers in order to respect conveying priorities at the end of the derivation.

Stopper simple or double effect, supplied with lateral guides, sensor bracket for detection of workpiece carriers.

The anti bouncing back is integrated in the lateral guides.

### Technical data

- ✘ Plate, al black
- ✘ Body and stopper PA
- ✘ Nuts 5 St M5 + screws
- ✘ Hole for shielded mounting sensor M12x100
- ✘ Detection range: 4 mm

Maximum load: 10 daN  
(in accumulation)



Flow rate controller M5 should be adapted

Weight: 0,14 kg

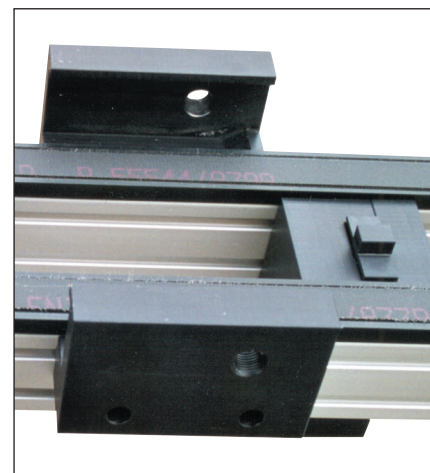
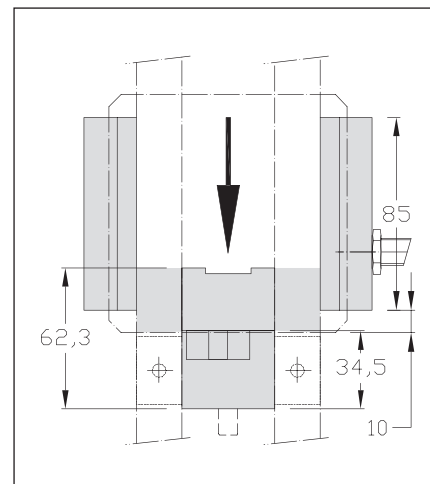
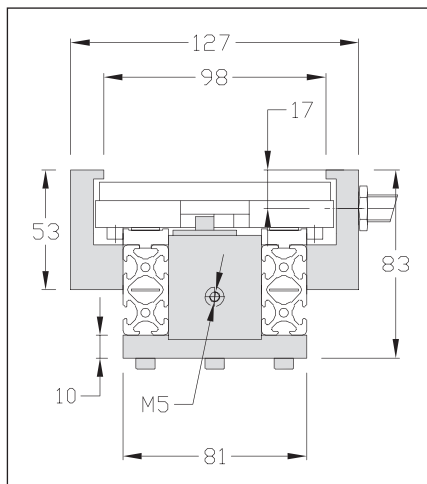

Designation / Dimensions	Order unit	Reference
Stopper 100 simple effect	1 pce	110.02.000
Stopper 100 double effect	1 pce	110.22.000



# Damped stopper, pneumatic Width 100

## APPLICATIONS

Stops workpiece carriers requiring no positioning accuracy.

Shock reduction between the workpiece carrier and the stopper thanks to the adjustable damped function.

Pneumatic control of the stopper, spring return.

Supplied with lateral guides and sensor bracket for workpiece carriers.

### Technical data

Complete set including:

- ✗ Stopper
- ✗ Stopper bracket
- ✗ Sensor bracket
- ✗ Screws and nuts

Maximum load /workpiece carrier  
(workpiece carrier included):

- 10 m/min: 9,5 kg
- 12 m/min: 9 kg
- 15 m/min: 8 kg
- 16 m/min: 7,5 kg
- 20 m/min: 6,5 kg

Air consumption: 0.036 l to 6 bars.  
Operating pressure: 4 to 8 bars.  
Longitudinal damping stroke: 7 mm

 1 connection M5 for the stopper is required.

Weight: 0.82 kg

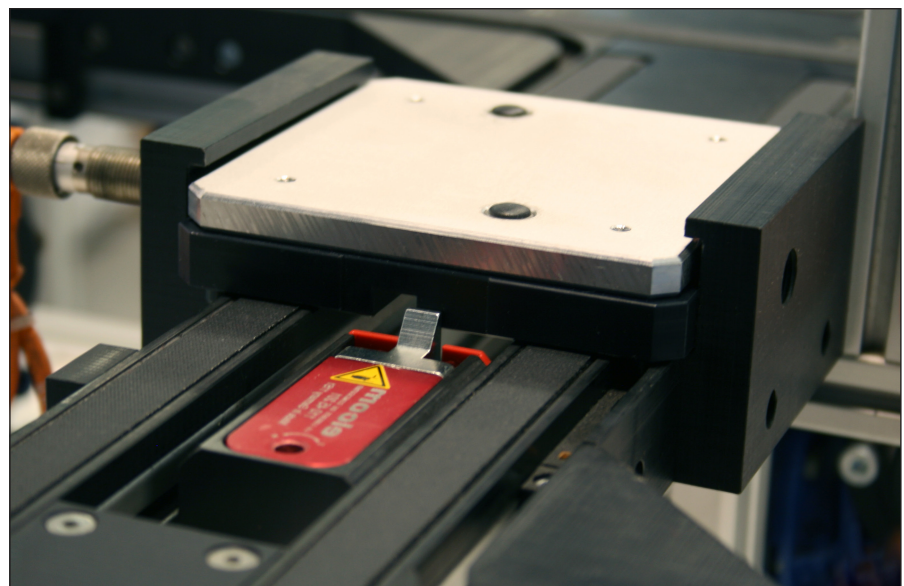
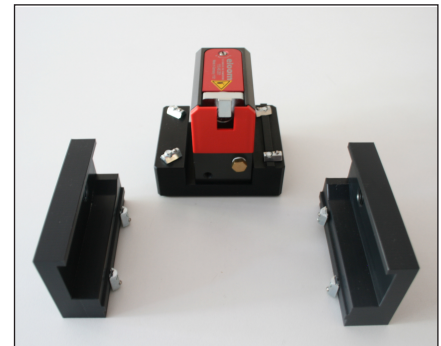
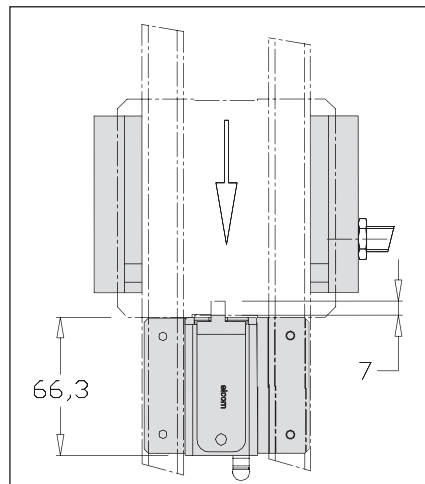
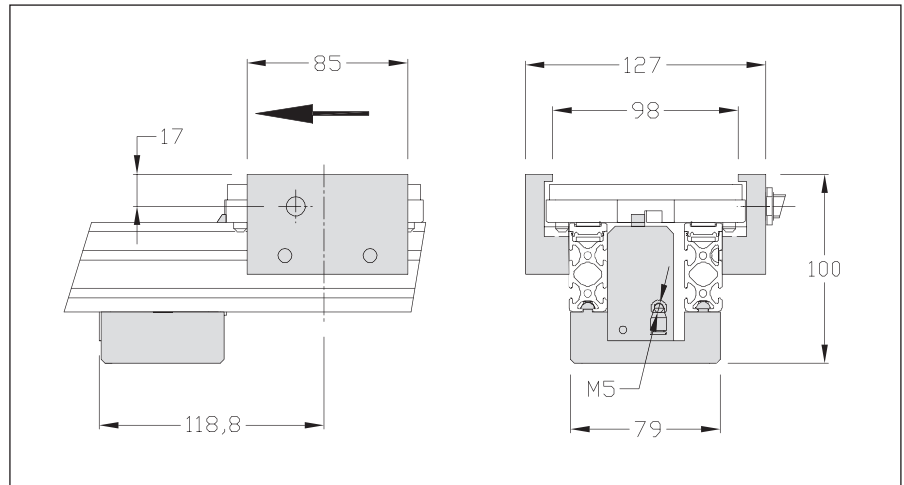

Designation / Dimensions	Order unit	Reference
Damped stopper 100 pneumatic	1 pce	110.45.000.RAP

## Stopper 24 V Width 100

### APPLICATIONS

It stops workpiece carriers requiring no accuracy during processing, perfectly adapted to manual work stations. Workpiece carriers are stopped to respect conveying priorities at the end of the derivation.

Simple effect stopper with spring return. Supplied with lateral guides and sensor bracket for the detection of workpiece carriers.

A Brushless gear motor controlled by a control box ensures the change in position. A single output for logic controller is necessary.

Control module 24 V output: automation, bus module, splitter, ...  
Standard connectors M12.

An extension for connection M8 male/female 3 pins between the motor and the control box is required.

The anti-bouncing back part is integrated into the lateral guides.

### Technical data

- ✗ Plate, stainless steel
- ✗ Body and stopper PA
- ✗ Nuts 5 St M5 + screws
- ✗ Hole for shielded sensor M12x100
- ✗ Detection range: 4 mm

Supply voltage of the control box:

24 VDC +/- 15%

Maximum power supply: 0.9 A

Control voltage: 24 VDC +/- 10 %

Control current: 5 mA maxi

Maximum load: 15 daN

(in accumulation)

Weight: 0.6 kg

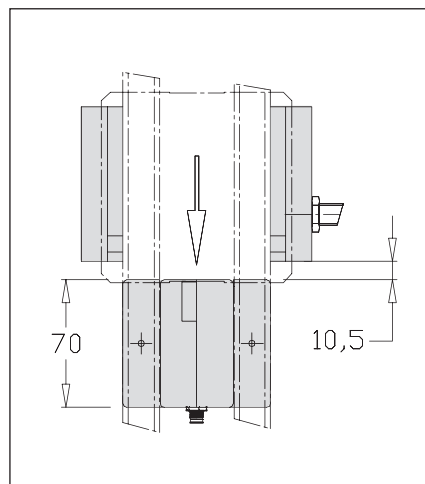
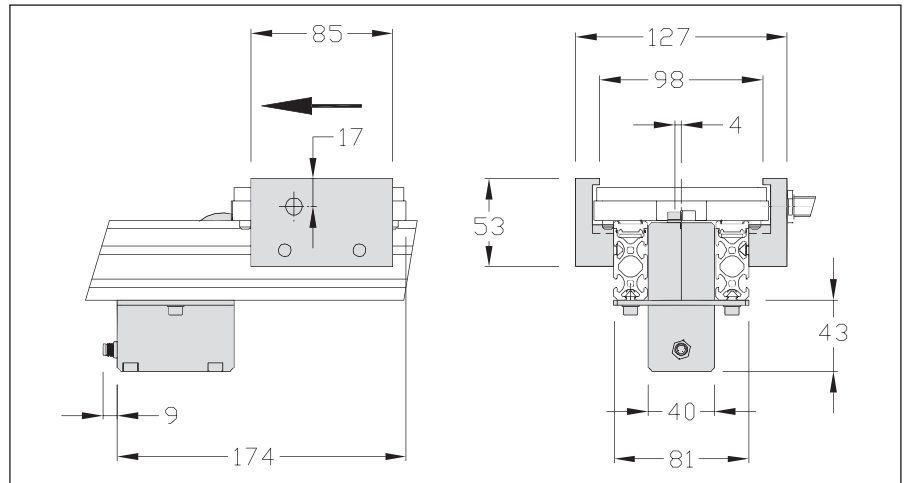

elcom ITS 24 V

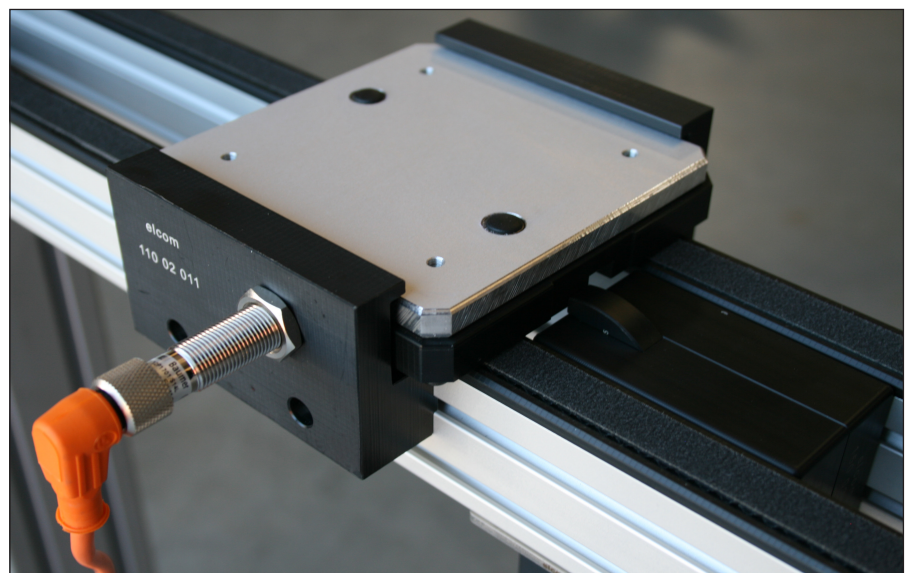

**Designation / Dimensions**

**Stopper 24 V 100**

**Order unit**

**1 pce**

**Reference**

**110.02.000.E**



## Applications TLM 1000

TLM 1000



## Positioning units

Stopping and positioning workpiece carriers for operations requiring accuracy.

The workpiece carrier is stopped, then lifted off the belts and positioned by a pin / locating system.

An automatic stopper is available for some positioning units. The vertical movement of the positioning unit plate unlocks the stopper.

All workpiece carriers must be stopped and the positioning unit plate must go up every cycle to liberate the workpiece carrier.

## Positioning units

The positioning unit is directly fitted on the conveying units.

3 possibilities: automatic stopper, simple effect stopper and double effect stopper.

Depending on the application, it is possible to choose the type of required control.

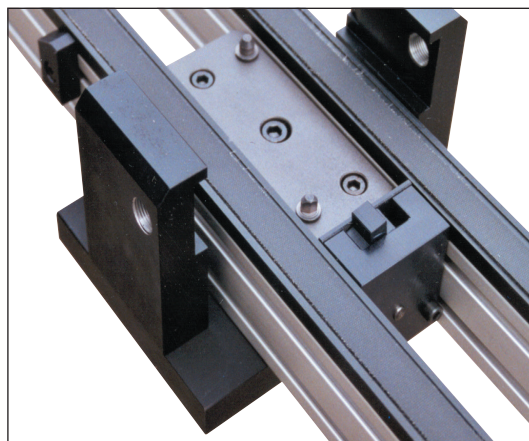

## Positioning units for station

They are fixed to a table or a frame to assure accuracy with the other surrounding elements.

A positioning set is necessary for operations requiring accuracy.

3 possibilities: automatic stopper, simple effect stopper and double effect stopper.

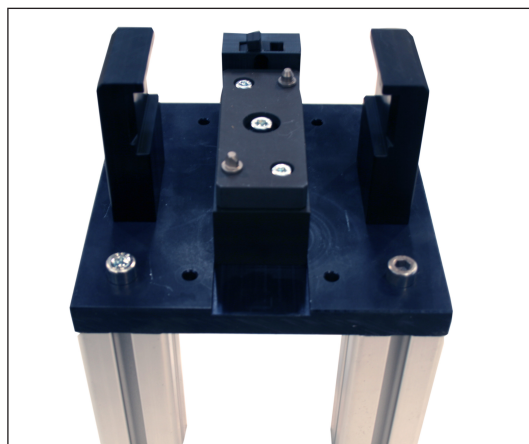

## Positioning unit for station 24 V Automatic stopper



It is fixed to a table or a frame to ensure accuracy with the other peripheral elements. A positioning kit is required for accurate operations.

The stopper of workpiece carriers is positioned by the vertical movement (unnecessary stopper control). A Brushless gear motor ensures the control of the stopper and the positioning unit.

Irreversible system.

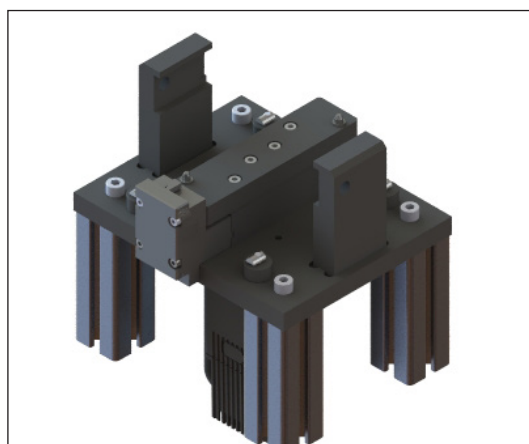

## Heavy positioning units

For operations requiring accuracy and involving important strain (up to 500 daN) at the centre of the workpiece carrier.

The positioning unit must be fixed on a frame capable of supporting the strain applied.

3 possibilities: automatic stopper, simple effect stopper and double effect stopper.

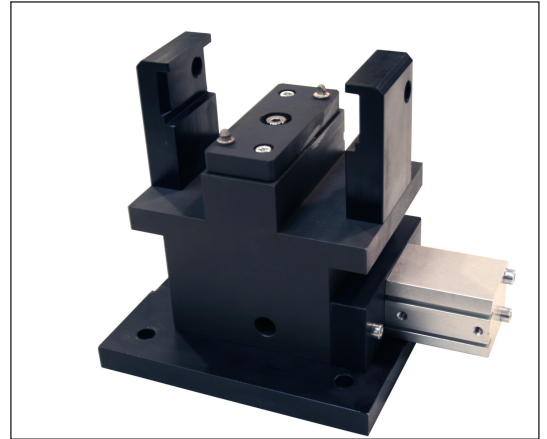

## Lift positioning units

Stop and positioning of workpiece carriers at a significant height above the conveyor.

The workpiece carrier is stopped, then elevated to a specific height, while being held by two centering pieces.

An upstream stopper is required.

2 possibilities: simple effect stopper, double effect stopper.

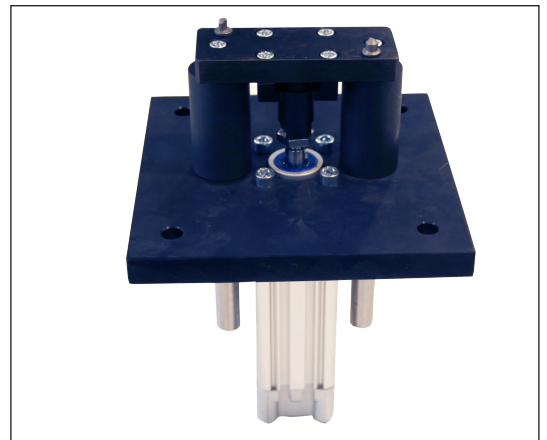

## Multi-positioning unit

Allow two accurate positionings of the workpiece carrier at the same station.

An upstream stopper is required.

1 possibility: automatic stopper.

On request: possibility to make a positioning unit with more positions.

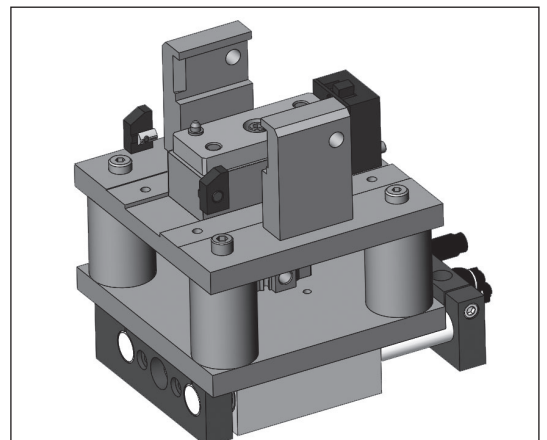



## Positioning units Width 100

### Technical data

Complete set including:

- ✘ Stopper
- ✘ Positioning unit
- ✘ 1 double effect cylinder  $\varnothing 32$ , detectable positions
- ✘ Holes for shielded mounting sensor M12x 100
- ✘ Detection range: 4 mm

Maximum vertical strain: 40 daN for a pressure of 6 bars

Repeatability: +/- 0,03 mm



2 flow rate controllers G 1/8 for positioning unit cylinder and controllers for the stopper should be adapted.

Weight: 2 kg

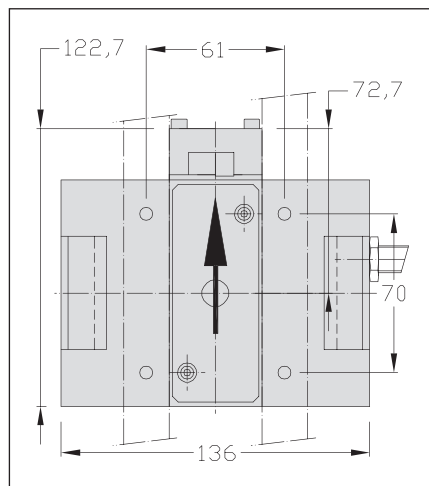
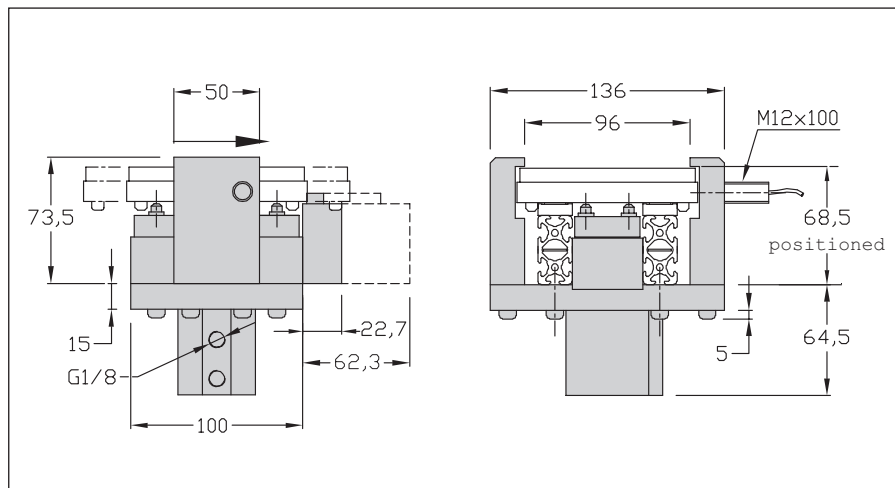

Positioning unit 100 with automatic stopper

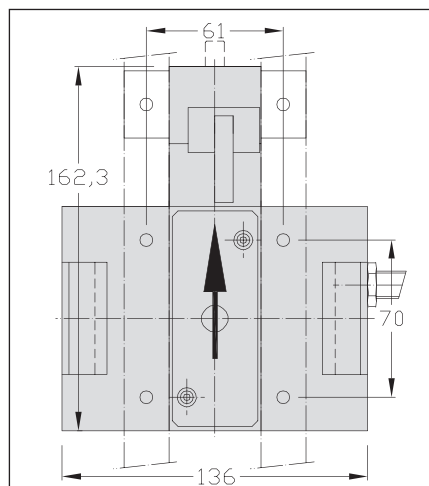

Positioning unit 100 with simple effect or double effect stopper

Designation / Dimensions	Order unit	Reference
Positioning unit 100	1 pce	110.09.000
Positioning unit 100 simple effect stopper	1 pce	110.24.000
Positioning unit 100 double effect stopper	1 pce	110.25.000

# Positioning unit, damped pneumatic stopper Width 100

## Technical data

Complete set including:

- ✘ Stopper
- ✘ Positioning unit
- ✘ 1 double effect cylinder  $\varnothing$  32, detectable positions
- ✘ Holes for shielding mounting sensors M12x100
- ✘ Detection range: 4 mm
- ✘ Fastening parts

Maximum vertical strain: 40 daN to 6 bars

Repeatability: +/- 0.03 mm



2 flow rate controllers G 1/8 for the cylinder of the positioning unit  
+ 1 connection M5 for the stopper  
are required.

Weight: 2.5 kg

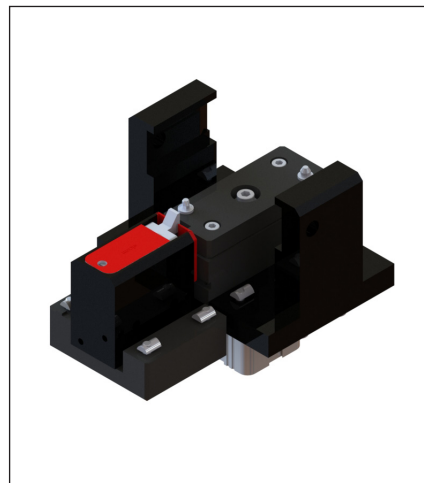
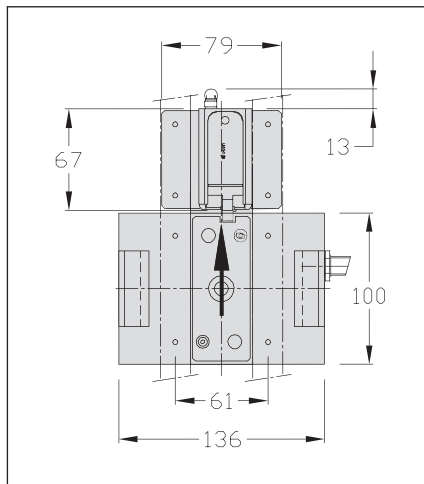
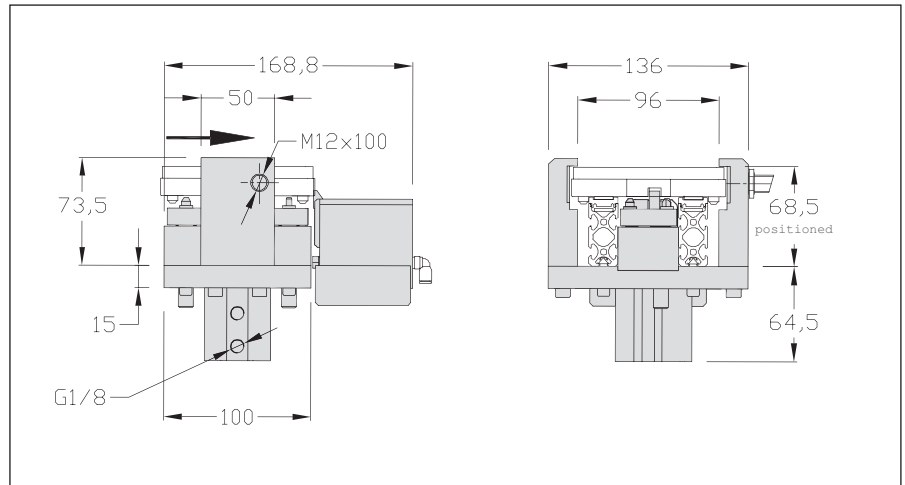

Designation / Dimensions	Order unit	Reference
Positioning unit 100 damped pneumatic stopper	1 pce	110.24.000.RAP

## Positioning units for station Width 100

### Technical data

Complete set including:

- ✘ Stopper
- ✘ Positioning unit
- ✘ 1 double effect cylinder ø 32, detectable positions
- ✘ Holes for shielded mounting sensor M12x100
- ✘ Detection range: 4 mm
- ✘ 4 supports in profile 40x40
- ✘ Fastening elements

Maximum vertical strain: 40 daN for a pressure of 6 bars.

Repeatability: +/- 0,03 mm



2 flow rate controllers G 1/8 for positioning unit cylinder and controllers for the stopper should be adapted.

Weight: 3,4 kg

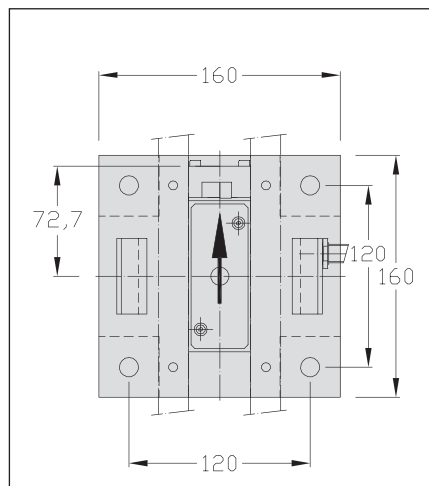
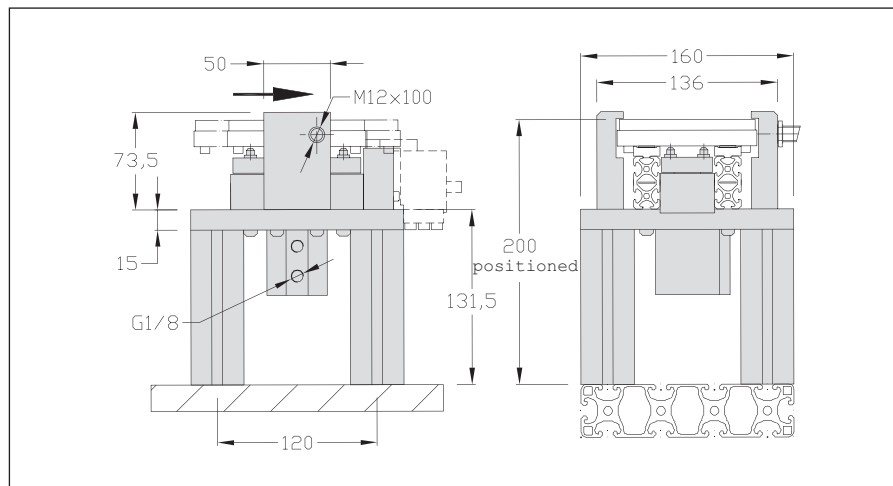

Positioning unit 100 with automatic stopper

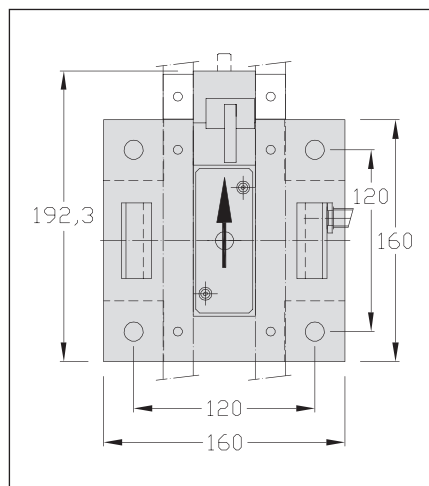

Positioning unit 100 with simple effect or double effect stopper

Designation / Dimensions	Order unit	Reference
Positioning unit for station 100	1 pce	110.10.000
Positioning unit for station 100 simple effect	1 pce	110.26.000
Positioning unit for station 100 double effect	1 pce	110.27.000

# Positioning unit for station, damped pneumatic stopper Width 100

## Technical data

Complete set including:

- ✘ Stopper
- ✘ Positioning unit
- ✘ 1 double effect cylinder  $\varnothing$  32, detectable positions
- ✘ Holes for shielding mounting sensors M12x100
- ✘ Detection range: 4 mm
- ✘ 4 profile stand 8 40x40
- ✘ Fastening parts

Maximum vertical strain: 40 daN to 6 bars

Repeatability: +/- 0.03 mm



2 flow rate controllers G 1/8 for the cylinder of the positioning unit + 1 connection M5 for the stopper are required.

Weight: 3.7 kg

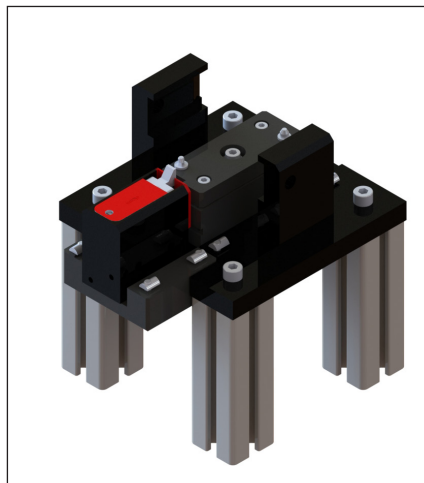
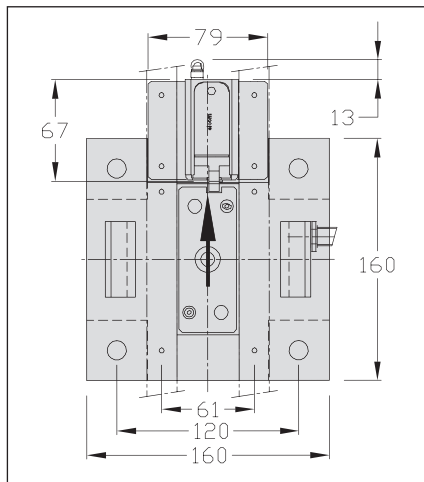
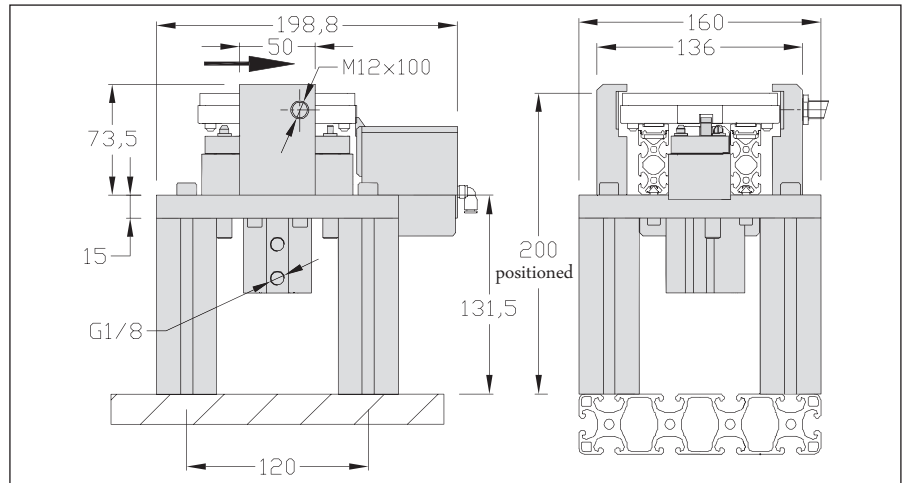

Designation / Dimensions	Order unit	Reference
Positioning unit for station 100 damped pneumatic stopper	1 pce	110.26.000. RAP

## Positioning unit for station 24 V Automatic stopper Width 100

### Technical data

Complete set including:

- ✘ 1 gear motor 24 V
- ✘ Vertical movement provided by an irreversible screw-nut system
- ✘ Vertical position controlled by encoder
- ✘ Housing for shielded mounting sensors M12x100
- ✘ Detection range: 4 mm
- ✘ 4 profile stands 8 40x40
- ✘ Fastening parts

Maximum vertical strain: 100 daN.

Repeatability: +/- 0.03 mm

Motor supply voltage: 24 VDC

Motor supply current: 5 A

Control voltage: 24 VDC

Control current: 10 mA

5 positioning input status

4 output status

The stopper of workpiece carriers is positioned by the vertical movement (unnecessary stopper control).

A Brushless gear motor ensures the control of the stopper and the positioning unit.

Irreversible system.

Weight: 7 kg

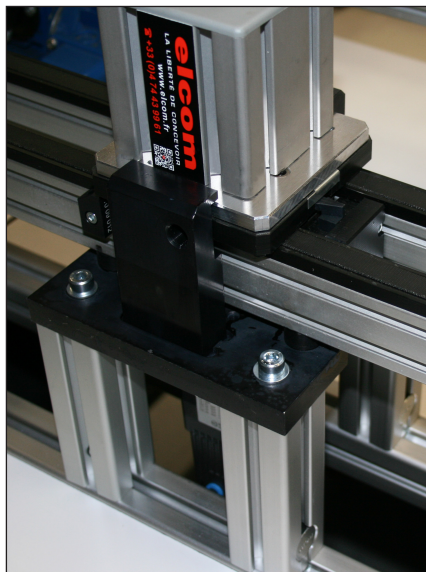
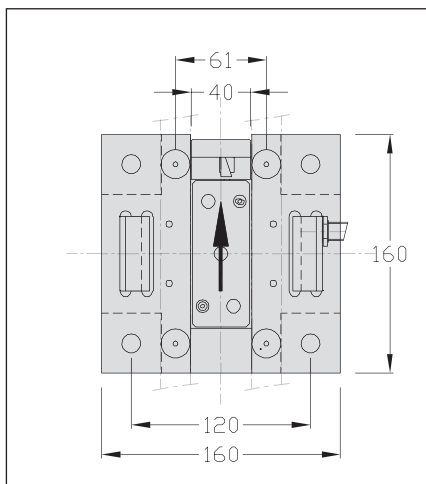
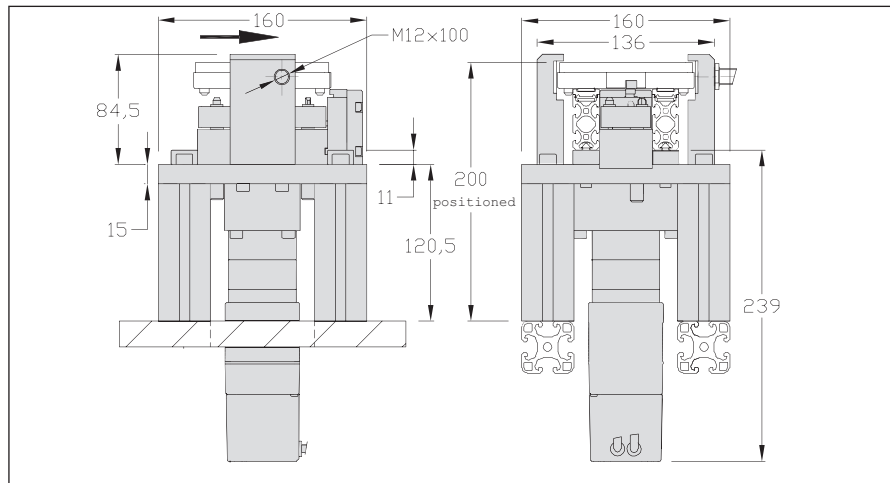

elcom ITS 24 V

Designation / Dimensions	Order unit	Reference
Positioning unit for station 24 V 100 Automatic stopper	1 pce	110.10.000.E



# Heavy positioning units Width 100

## Technical data

Complete set including:

- ✘ Stopper
- ✘ Positioning unit
- ✘ 1 double effect cylinder  $\varnothing 25$ , detectable positions
- ✘ Holes for shielded mounting sensor M12x100
- ✘ Detection range: 4 mm

Maximum vertical strain: 500 daN at the centre of the workpiece carrier.

Repeatability: +/- 0,03 mm



2 flow rate controllers M5 for positioning unit cylinder and controllers for the stopper should be adapted.

Weight: 8,7 kg

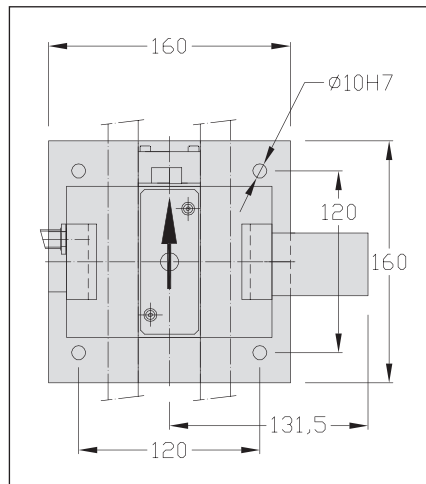
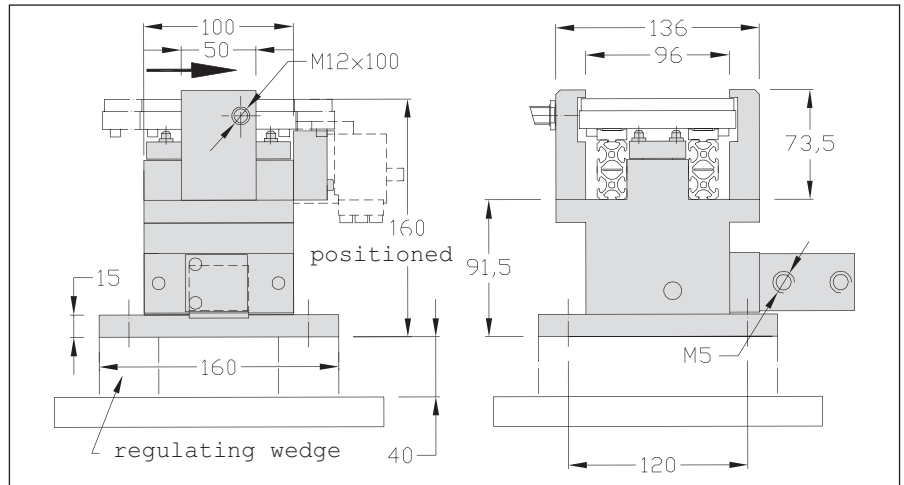

Positioning unit 100 with automatic stopper

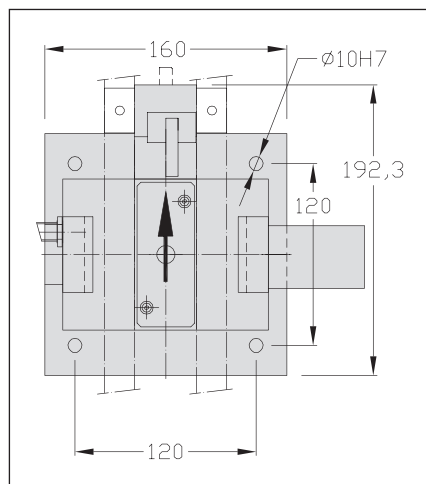

Positioning unit 100 with simple effect or double effect stopper

Designation / Dimensions	Order unit	Reference
Heavy positioning unit 100	1 pce	110.11.000
Heavy positioning unit 100 simple effect	1 pce	110.28.000
Heavy positioning unit 100 double effect	1 pce	110.29.000

## Heavy positioning unit, damped pneumatic stopper Width 100

### Technical data

Complete set including:

- ✘ Stopper
- ✘ Positioning unit
- ✘ 1 pneumatic cylinder double effect  $\varnothing 25$ , detectable positions
- ✘ Holes for shielding mounting sensors M12x100
- ✘ Detection range: 4 mm

Maximum vertical strain: 500 daN  
at the center of the workpiece carrier.

Repeatability: +/- 0,03 mm



2 flow rate controllers G 1/8 for the cylinder of the positioning unit + 1 connection M5 for the stopper are required.

Weight: 9 kg

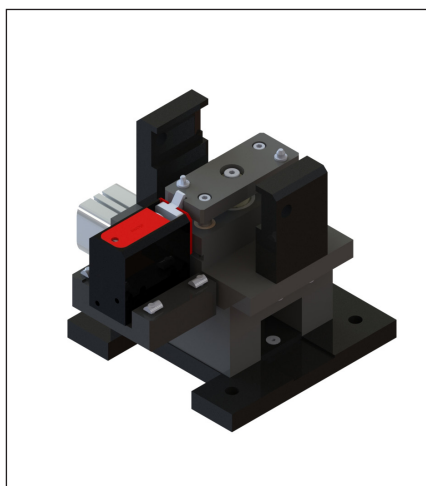
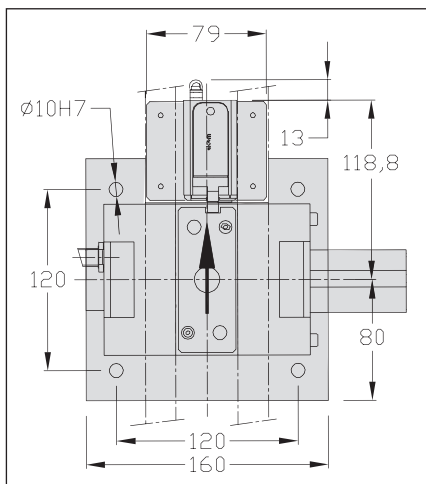
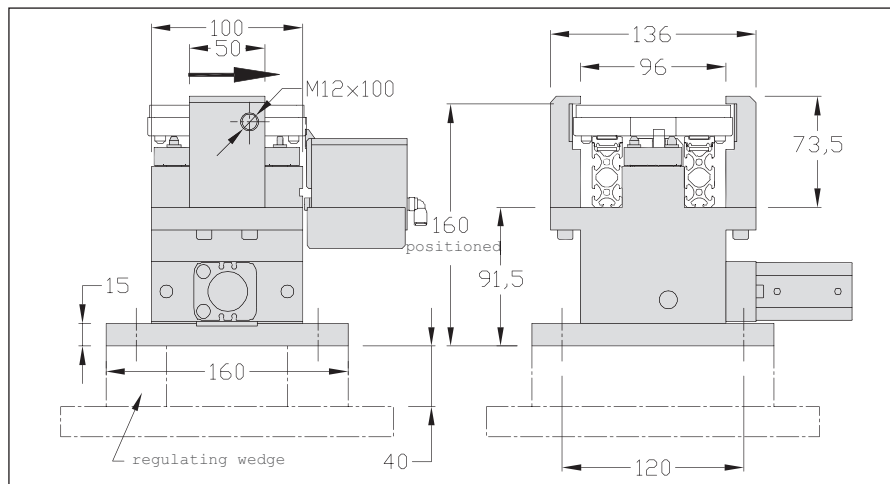

**Designation / Dimensions**

**Heavy positioning unit 100 damped pneumatic stopper**

**Order unit**

**1 pce**

**Reference**

**110.28.000.RAP**

## Lift positioning units Width 100

### Technical data

Complete set including:

- ✘ Impulse controlled stopper and anti bouncing back devices
- ✘ 1 double effect cylinder  $\varnothing$  32
- ✘ Ball bearing guide bush  $\varnothing$  14
- ✘ 1 bracket support for shielded mounting sensor M12x100
- ✘ Detection range: 4 mm

Available cylinder strokes:  
25-50-100-160-200 mm

Maximum vertical strain: 40 daN

Repeatability: +/- 0,06 mm

A stopper located before the lift unit is generally necessary to avoid the arrival of another workpiece carrier during lifting.



2 flow rate controllers G 1/8 for positioning unit cylinder and controllers M5 for the stopper should be adapted.

Weight: 3,4 kg

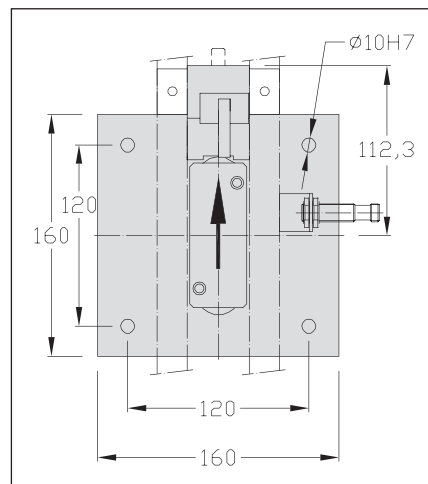
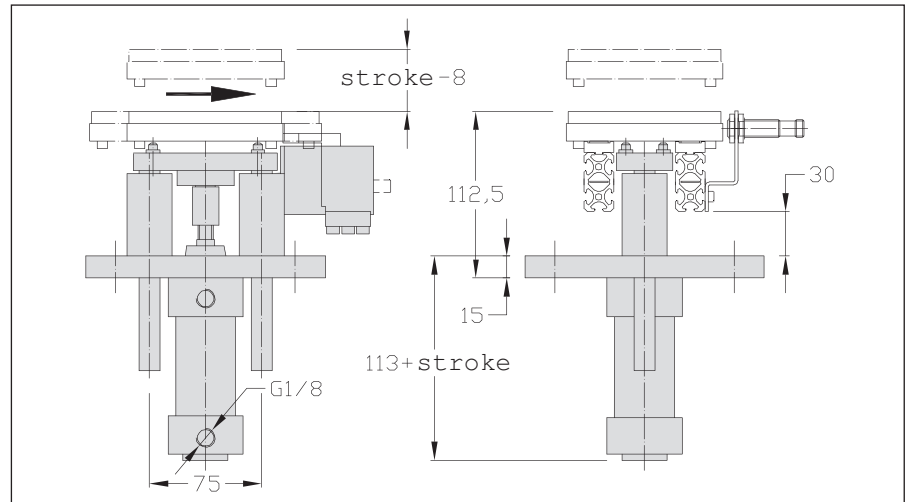

Designation / Dimensions	Order unit	Reference
Lift positioning unit 100 simple effect	1 pce	110.12.000
Lift positioning unit 100 double effect	1 pce	110.31.000

## Lift positioning unit, damped pneumatic stopper Width 100

### Technical data

Complete set including:

- ✘ Stopper
- ✘ 1 double effect cylinder  $\varnothing$  32
- ✘ 1 ball bearing guide bush  $\varnothing$  14
- ✘ 1 bracket for shielded mounting sensor M12x10
- ✘ Detection range: 4 mm

Available cylinder strokes:

25 - 50 - 100 - 160 - 200 mm

Maximum vertical strain: 40 daN

Repeatability:  $\pm$  0,06 mm



An upstream stopper is required to prevent the inlet of a workpiece carrier during the lifting.



2 flow rate controllers G 1/8 for the cylinder of the positioning unit  
+ 1 connection M5 for the stopper are required.

Weight: 3.7 kg

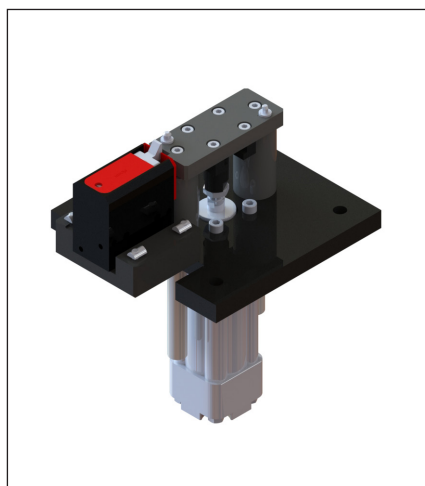
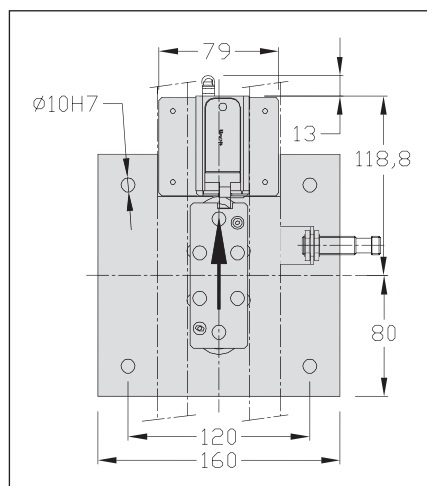
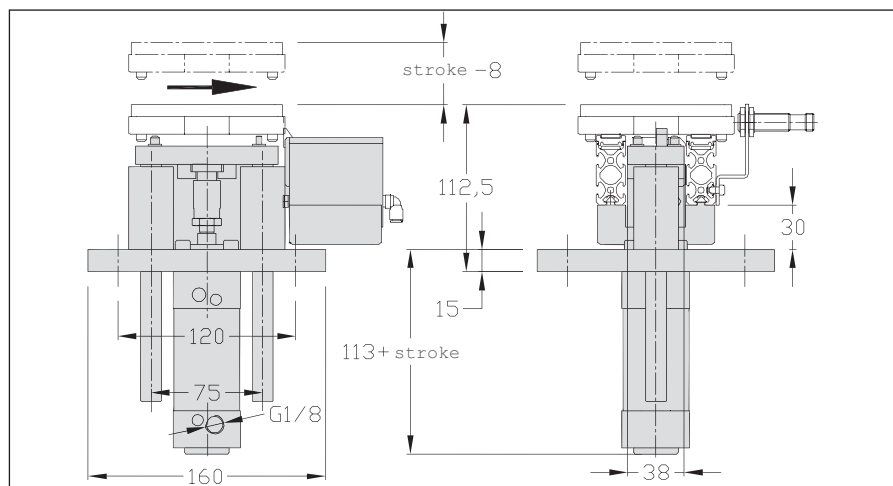

**Designation / Dimensions**

**Lift positioning unit 100 damped pneumatic stopper**

**Order unit**

**1 pce**

**Reference**

**110.12.000.RAP**

## Dead man option, lift positioning units Width 100

This option is available for all lift positioning units width 100 (references 110.12.000 - 110.12.000.RAP - 110.31.000).

The dead man option is used to lock the lift positioning unit in case of air cut-off and therefore avoid the lowering of the load.

Locking by springs.

Retaining force: 600 N

Useful pressure range: 6 bars.



2 flow rate controllers G 1/8  
+ 1 connection M5 are required.

Weight: 1.25 kg (stroke 200).

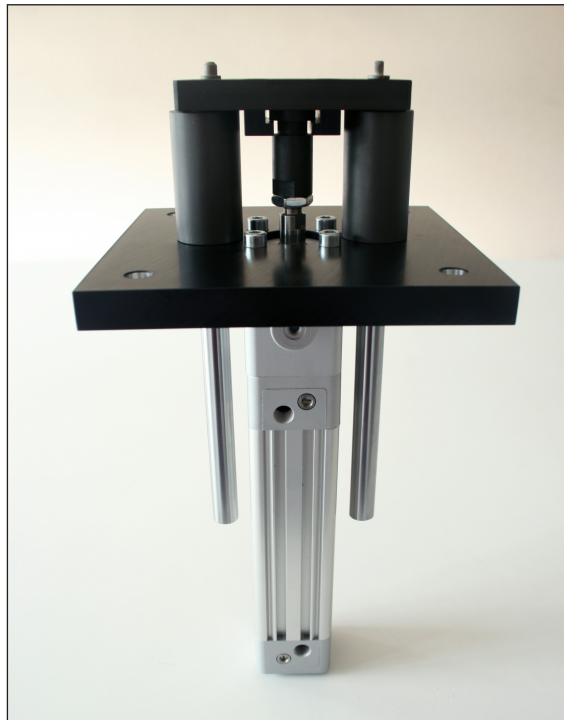
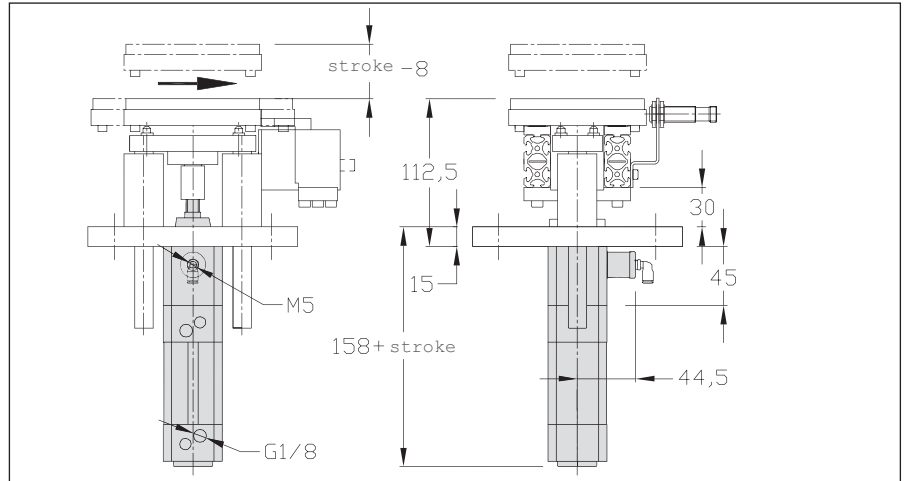

Designation / Dimensions	Order unit	Reference
Dead man option, Lift positioning units 100	1 pce	110.75.000



## Multi-positioning unit Width 100

### Technical data

Complete set including:

- ✘ Automatic stopper
- ✘ Positioning unit 100
- ✘ Slide PS 20
- ✘ Strokes: 50-100 or 200

The slide is fitted with shock absorbers and stop screws with integrated sensors.

Maximum vertical strain:

stroke 50 or 100: 40 daN

stroke 200: 20 daN

Repeatability: +/- 0,04 mm

A stopper located before the lift unit is generally necessary to avoid the arrival of another workpiece carriers during the slide moving.

Different multi-positioning units on request



2 flow rate controllers G 1/8 for positioning unit cylinder should be adapted

Weight: 7,4 kg

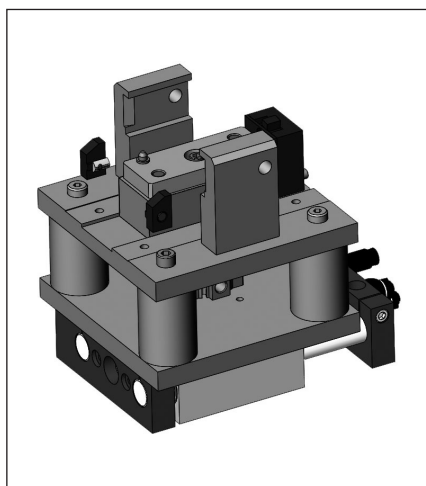
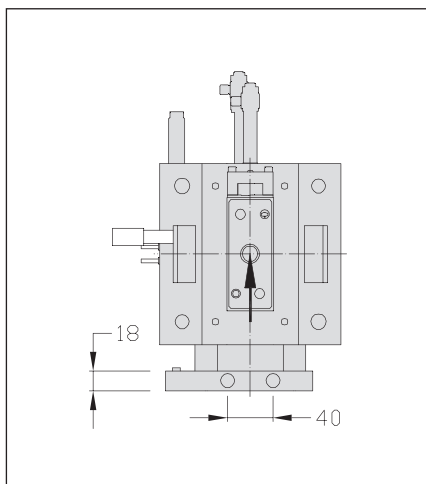
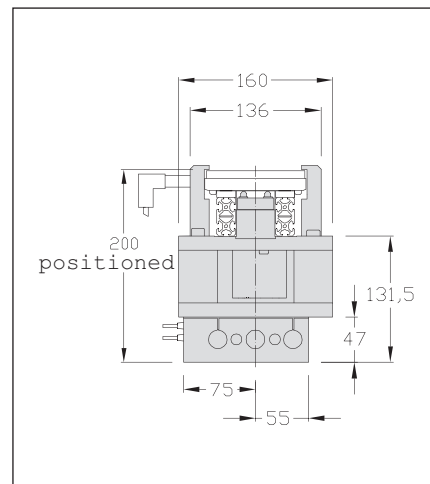
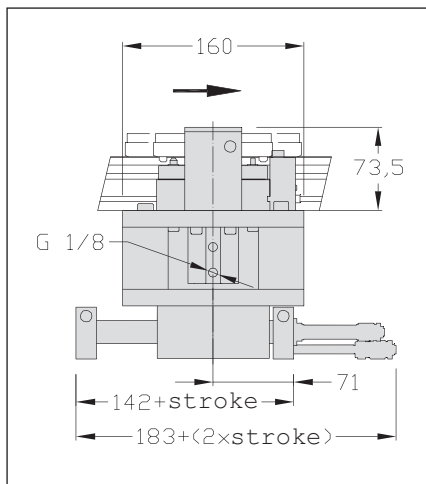

**Designation / Dimensions**

**Multi-positioning unit 100**

**Order unit**

**1 pce**

**Reference**

**110.19.000.\*\*\***

(\*\*\* = Strokes 50-100-200 eg: Stroke 50 110.19.000.050)

## 90° swivelling Width 100

### APPLICATIONS

90° swivelling of workpiece carriers by blocking and retracting the pins.

It is necessary to associate two 90° swivellings to have a 180° swivelling

#### Technical data

- ✘ Plates and guides, PA black
- ✘ 2 cylinders ø 16-5 (M5)
- ✘ 2 bracket supports for shielded mounting sensor M12x100
- ✘ 1 cylinder ø 12-10 M5

Minimum load on the workpiece carrier:  
0,3 daN

A stopper located before the swivelling unit is generally necessary to avoid the arrival of another workpiece carrier during swivelling.

Weight: 1,8 kg

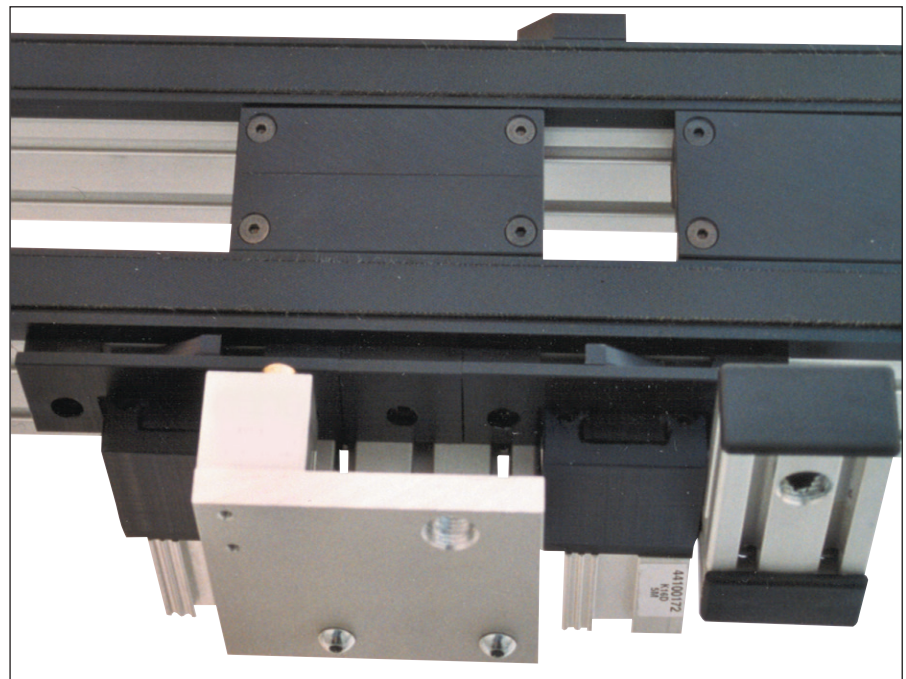
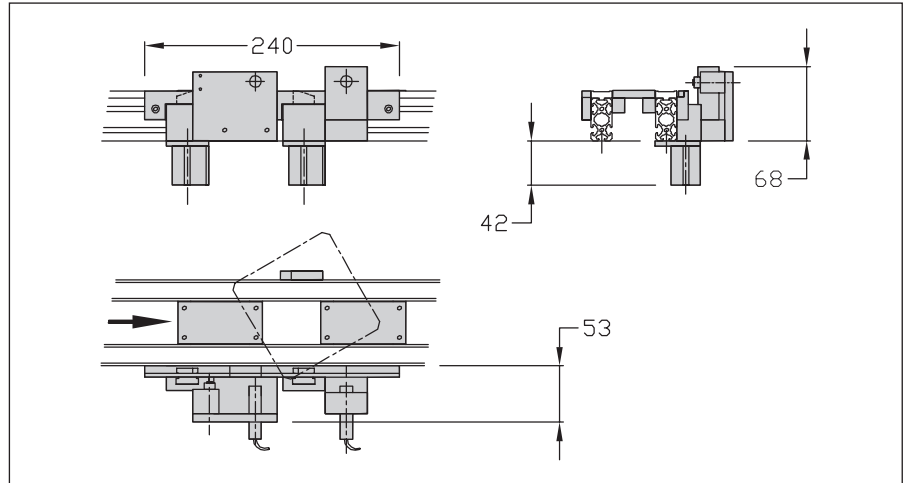

Designation / Dimensions	Order unit	Reference
90° swivelling 100	1 set	110.14.000

## Sensor bracket M 12x100

### APPLICATIONS

Bracket for workpiece carrier M12x100 sensor.

#### Technical data

- ✘ Stainless steel 2 mm
- ✘ Nut 5 St M4 + screws
- ✘ Detection range: 4 mm

Weight: 0,035 kg

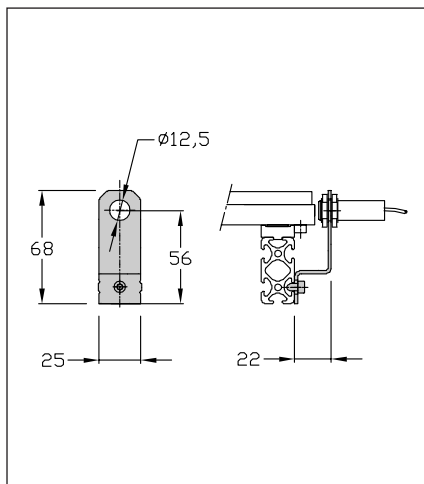

Designation / Dimensions	Order unit	Reference
Sensor bracket 100	1 pce	110.17.000

## Anti bouncing back

### APPLICATIONS

Avoids workpiece carrier bouncing back on stoppers or positioning units in case of high speed.

Allows to reduce the changing time of workpiece carrier in the positioning unit.

#### Technical data

- ✘ Parts, PA black
- ✘ Fastening parts

Weight: 0,1 kg

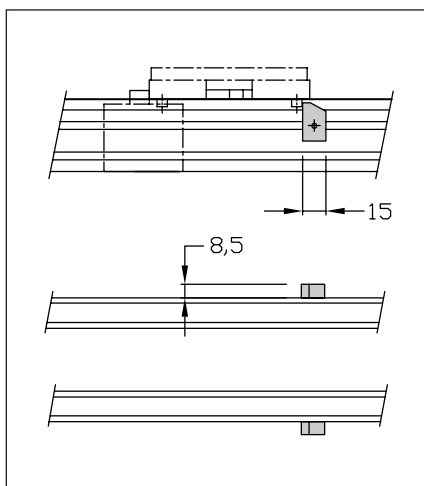

Designation / Dimensions	Order unit	Reference
Anti bouncing back 100	1 set	110.30.000

## Positioning kit

### APPLICATIONS

Allows accurate positioning unit on station.

#### Technical data

- x 2 axis screws M8
- x 2 hexagonal socket head cap screws M8

Weight: 0,08 kg

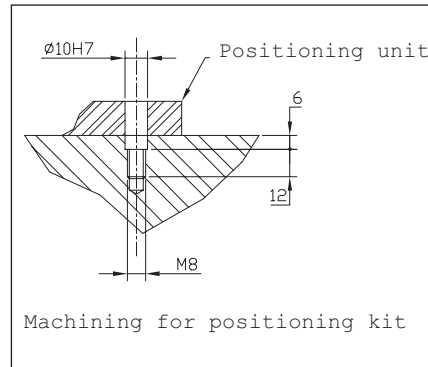

Designation / Dimensions	Order unit	Reference
Positioning kit	1 kit	120.62.000

## Inductive sensor M 12x100

### APPLICATIONS

Detection for the workpiece carrier.

#### Technical data

- x Shielded mounting sensor M12x100
- x LED control display
- x PNP-10-30 VDC
- x Screwed connection
- x Cable 5 m



Designation / Dimensions	Order unit	Reference
Inductive sensor M 12x100	1 set	200.10.200

## Cylinder sensors

### APPLICATIONS

Detection the position of cylinders, stoppers or positioning units.

#### Technical data

- x 12-27 V-LED control display

Designation / Dimensions	Order unit	Reference
Cylinder sensor, positioning unit	1 set	200.10.201
Cylinder sensor, lift positioning unit	1 set	200.10.202

Conveying unit 24 V  
p 71



elcom ITS 24 V

Positioning unit for station  
24 V automatic stopper  
p 91

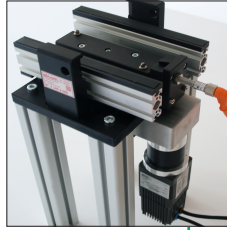

elcom ITS 24 V

Lift positioning  
p 92

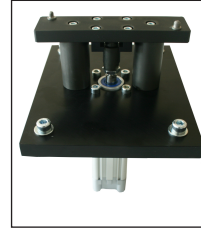

Workpiece carrier  
p 66

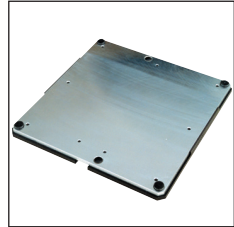

Conveying unit  
p70

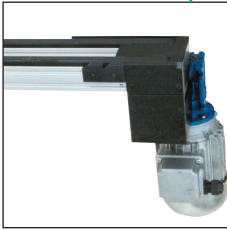

Positioning unit  
for station  
p 89

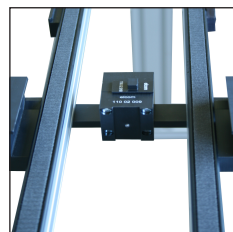
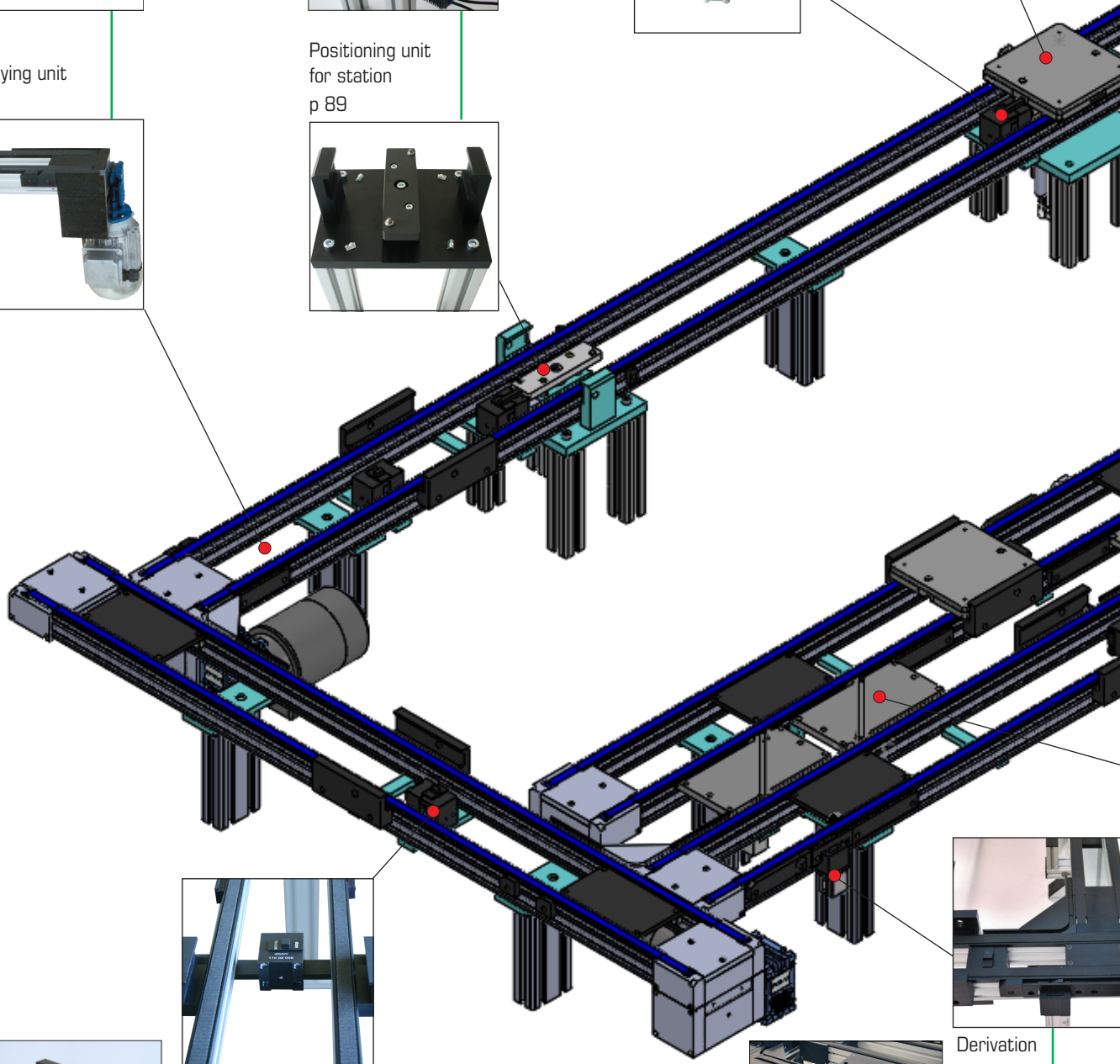
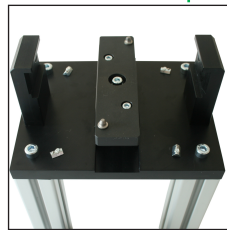

Stopper  
p 80

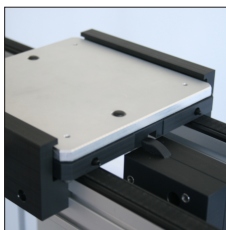

Stopper 24 V  
p 82



elcom ITS 24 V

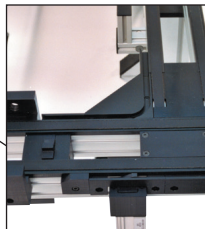

Derivation  
p 78

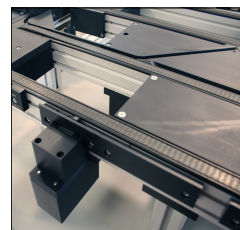

Derivation 24 V  
p 79



elcom ITS 24 V



Cap for motorization  
p 74

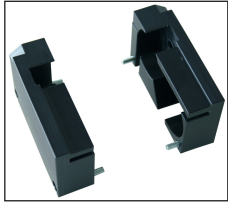

Cam  
p 76

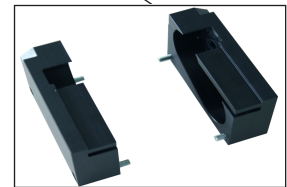
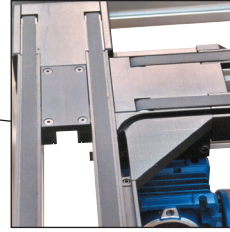

Cap for idling unit  
p 74

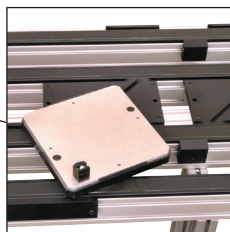

Short cam  
p 98

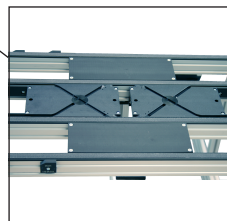

Double cam  
p 99



Conveying unit stand  
p 75

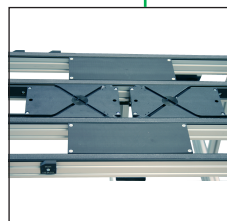

Double cam 24 V  
p 100





## Index TLM 1500

Designation	Page
Data.....	65
Workpiece carriers .....	66
Workpiece carriers U, grinded Width 150.....	68
Workpiece carriers M, grinded Width 150.....	69
Conveying unit timing belt .....	70
Conveying unit 24 V timing belt .....	71
Conveying unit timing belt Width 150 .....	72
Conveying unit 24 V timing belt Width 150.....	73
Spacer Width 150 .....	74
Caps Width 150 .....	74
Straight joining Width 150.....	75
Conveying unit stand .....	75
Cams 90° .....	76
Cams 90° Width 150.....	77
Derivations Width 150 .....	78
Derivations 24 V Width 150 .....	79
Stoppers, simple-double effect Width 150.....	80
Damped stopper, pneumatic Width 150 .....	81
Stopper 24 V Width 150 .....	82
Positioning units .....	84
Positioning units Width 150.....	87
Positioning unit, damped pneumatic stopper Width 150.....	88
Positioning units for station Width 150 .....	89
Positioning unit for station, damped pneumatic stopper 150.....	90
Positioning unit for station 24 V Automatic stopper Width 150 ..	91
Lift positioning units Width 150.....	92
Lift positioning unit, damped pneumatic stopper Width 150 .....	93
Dead man option, lift positioning units Width 150.....	94
Sensor bracket M12x100 .....	95
Anti bouncing back.....	95
Short cams .....	96
Double cams - double cams 24 V .....	97
Short cams SD-EG, SG-ED Width 150.....	98
Double cam Width 150.....	99
Double cam 24 V Width 150 .....	100
Positioning kit.....	101
Inductive sensor M12x100 .....	101
Cylinder sensors.....	101

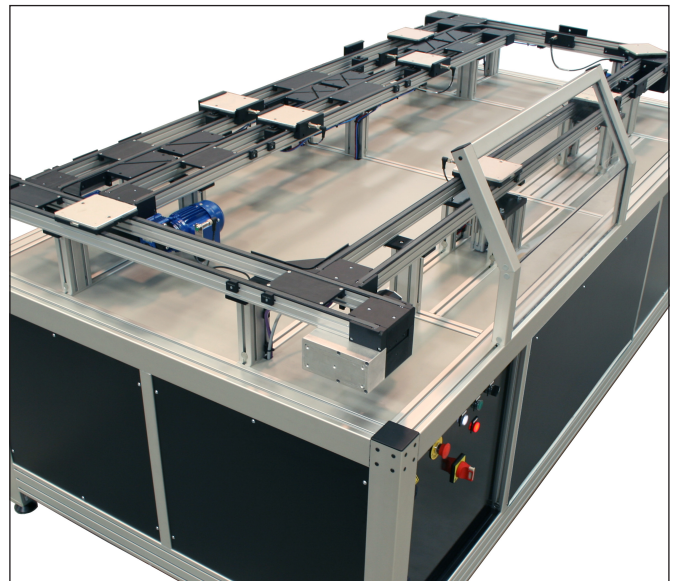
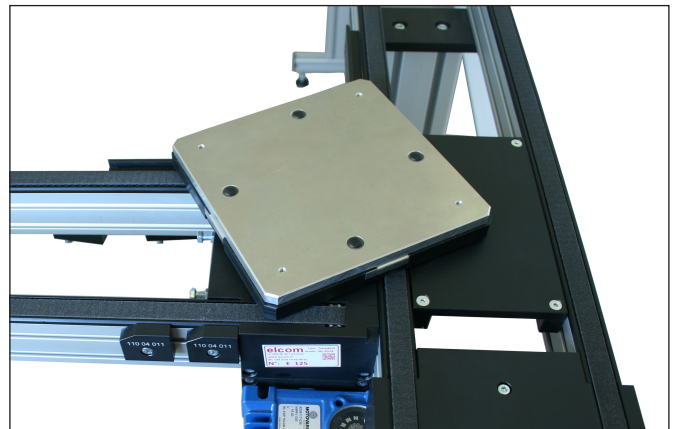

## Data

	<b>TLM 1500</b>
Workpiece carriers (mm)	155x155
Load/workpiece carrier (daN)	4
Speed (m/min) Timing belt	12-16
Length of conveying unit Mini Maxi	500 3160
Maxi accumulation load per motor (daN) Timing belt	35
Absolute maximum load (daN) Timing belt	70 daN / 3m
Motor power (380 V three-phase)	0,09 KW-0,4 A

The maximum length of the conveying units is: 3160 mm.

For long spans, several elements can be butted end to end.

For important accumulations, the length of the conveying units must be adapted to the load.

It is recommended to place sensors in order to control accumulation of the load.

Pneumatic cylinders must be equipped with flow rate controllers.

It is possible for long spans to have conveyor's cut done in order to facilitate the dismantling of the machines.

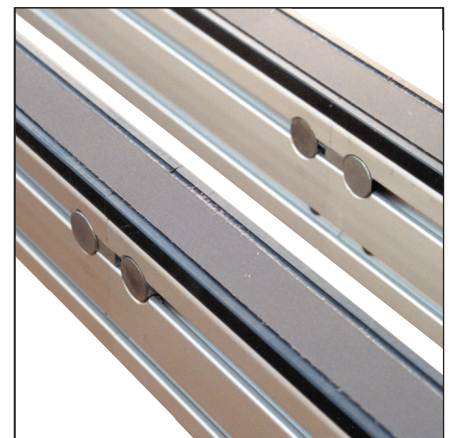

Conveyor's cut profile butted end to end

Download all CAD 3D files



**on our website**  
**www.elcom-automation.**  
**com/transfers**

## Workpiece carriers

The workpiece carriers allow the mounting of holders which ensure an accurate positioning of the assembly during the process.

The workpiece carriers consists of two plates.

The upper aluminium plate allows the fastening of workpieces, ensures the geometrical behaviour workpiece carrier as well as the positioning accuracy. Machining (drillings and tappings) can be made according to the customer's wish.

Stainless steel bushes located in the aluminium plate guarantee

resistance to wear and a perfect accuracy. The PA base has an extremely low friction coefficient and lays on the conveying belts. This base hosts 4 guiding pins (specific to **elcom**) and has the necessary shape to ensure stoppers proper functioning.

Metallic bars are located on each side of the workpiece carrier in order to detect them at several workstations. The characteristics of stoppers, guiding pins with springs can be found in the next pages.

### Variable length of **elcom's** workpiece carriers and specific workpiece carriers

Standard workpiece carriers are available to install the workpieces that will be conveyed. In many cases, the surface area of workpiece carrier is not sufficient. Specific workpiece carriers can be supplied. The use of 4 guiding pins makes it possible to vary the length of workpiece carrier and to optimize cycle times. The guiding pins remain in the

position of the nearest standard workpiece carrier. So, all the standard elements such as cams are usable without modification.

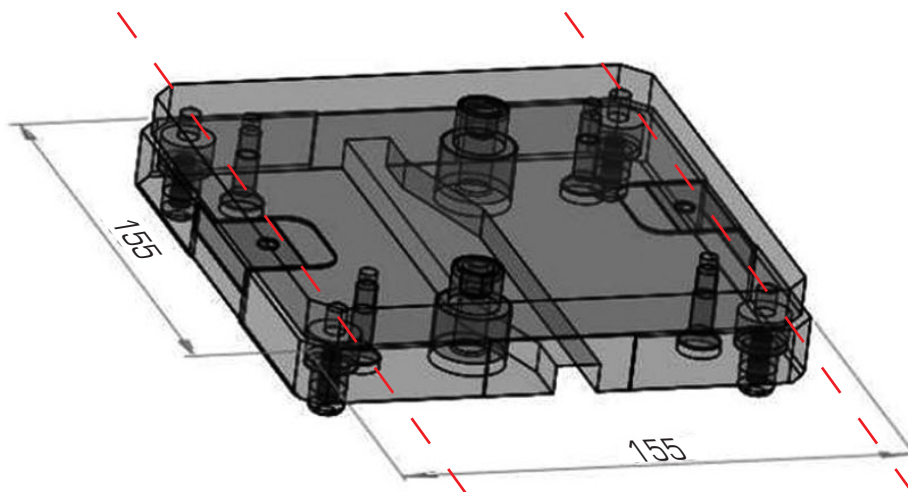

## Workpiece carriers U and M

Workpiece carriers are used to support and position the components during the process.

The upper plate (made of aluminium) is used to fix the components and perform an accurate positioning of the workpiece carrier.

The PA base (which has a very low friction coefficient) is used to shelter the pins and to stop the workpiece carrier on the stopper.

Steel bushes ensure perfect accuracy and resistance against deterioration.

On each side of workpiece carrier, small metallic bars allow detection of workpiece carriers at various positions.

### Unidirectional workpiece carriers

They are perfectly compatible with a 180° swivelling.

Possibility of adding shock absorbers to limit the shock between the workpiece carriers and to reduce the noise (T).

### Multidirectional workpiece carriers

For square workpiece carriers only.

They are perfectly compatible with 90°, 180° and 270° swivellings, delivered with 2 bushes and 2 additional detection bars.

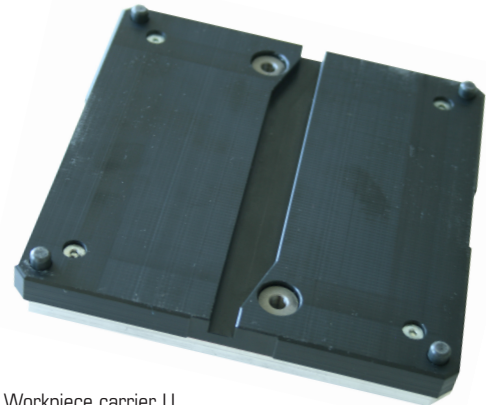

Workpiece carrier U



Workpiece carrier M

## Workpiece carriers with shock absorber T

The PA base is provided with two drills on the side in the direction of motion. Shock absorbers are inserted in these drills.

These damp the impact between two workpiece carriers and therefore reduce noise pollution.

The workpiece carrier with shock absorber T corresponds to the standard U-type workpiece carrier.



**The use of workpiece carrier with shock absorbers requires the installation of a stopper before each positioning unit.**

**This avoids the shearing of shock absorbers.**



Workpiece carrier with shock absorber

## Grinded workpiece carriers (G)

The upper aluminium plate of the grinded workpiece carrier ensures a great dimensional stability and a positioning accuracy. It has a higher flatness than a standard workpiece carrier. These workpiece carriers

are recommended if large openings or millings in the aluminium plate are carried out. Their structure correspond to the standard workpiece carriers.

## Workpiece carriers U, grinded, T Width 150

### Technical data

- ✘ Plate Al (grinded with the option G)
- ✘ Base, PA black
- ✘ 2 steel bushes
- ✘ 4 pins PA
- ✘ 4 springs
- ✘ 4 countersunk screws M4x16
- ✘ 2 detection bars
- ✘ 2 plugs

Add T at the end of reference to mention shock absorber option

Add G at the end of reference to mention grinded option

 Maximum load: 4 daN

Weight: 0,83 kg

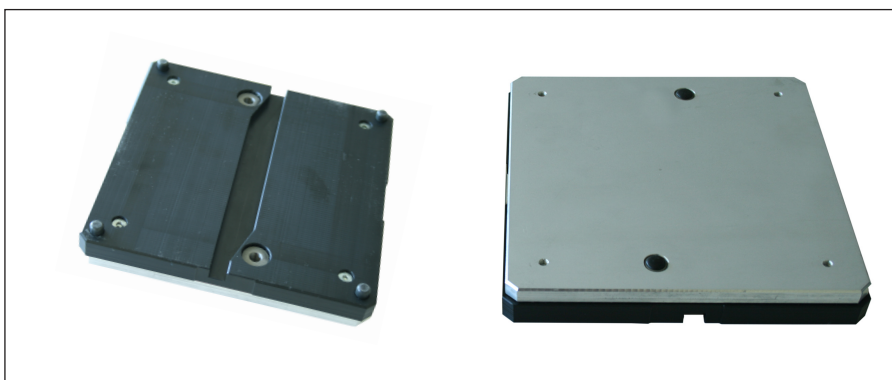
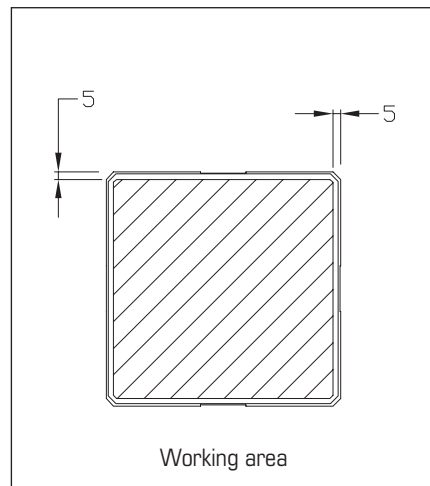
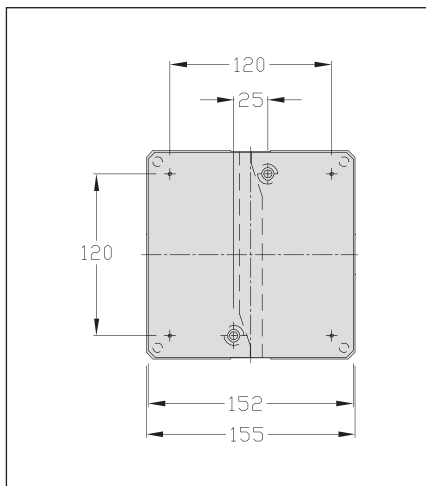
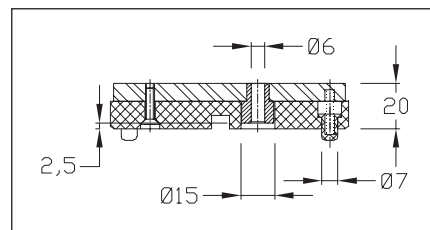
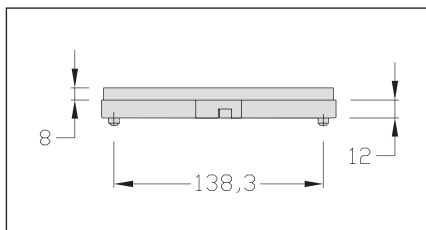

Designation / Dimensions	Order unit	Reference
Workpiece carrier U 150x150	1 pce	150.62.000
Workpiece carrier U 150x150 T	1 pce	150.62.000.T
Workpiece carrier U 150x150 grinded	1 pce	150.62.000.G
Workpiece carrier U 150x150 T grinded	1 pce	150.62.000.TG



# Workpiece carriers M, grinded Width 150

## Technical data

- ✘ Plate Al (grinded with the option G)
- ✘ Base, PA black
- ✘ 4 steel bushes
- ✘ 4 pins PA
- ✘ 4 springs
- ✘ 4 countersunk screws M4x16
- ✘ 4 detection bars
- ✘ 4 plugs

Add G at the end of reference to mention grinded option

 Maximum load: 4 daN

Weight: 0,92 kg

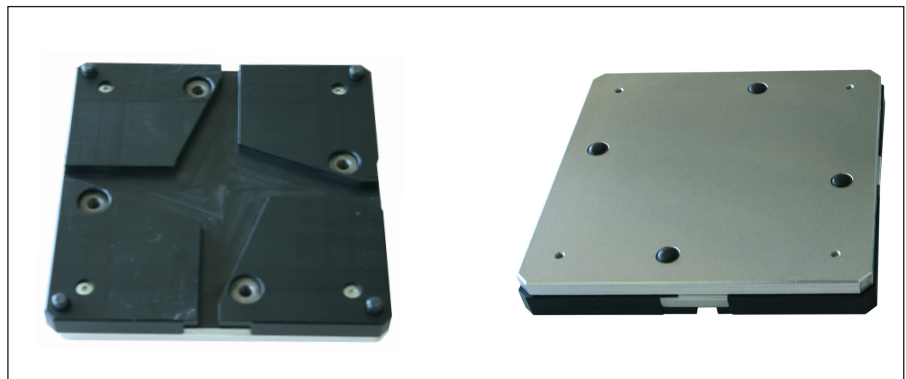
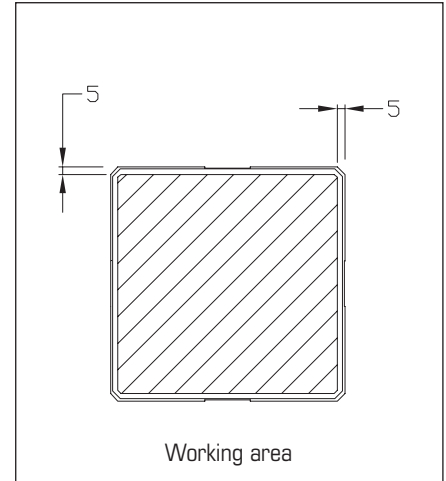
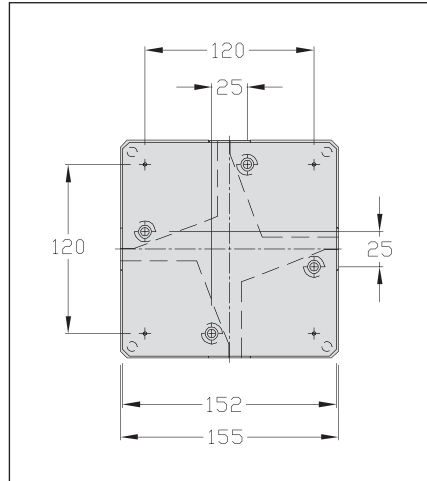
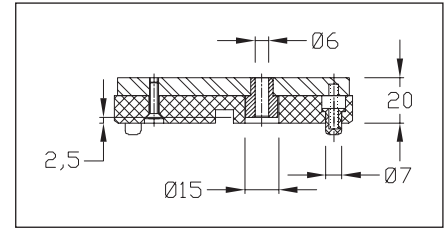
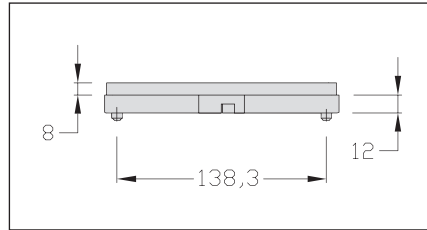

TLM 1500

Designation / Dimensions	Order unit	Reference
Workpiece carrier M 150x150	1 pce	150.64.000
Workpiece carrier M 150x150 grinded	1 pce	150.64.000.G

## Conveying unit timing belt

Moving and accumulating of workpiece carriers 150x150.

The motor can be fitted either vertically or horizontally, on the right or the left side.

The use of timing belts enables to increase the carried load and facilitates the maintenance when changing belts. Belt guides are pressed into aluminium profile housing.

According to the load, longer spans can be joined end to end by straight joinings.

The cuttings of conveyors allow division of the lengths, making transport and installation of the lines easier.

The installation is facilitated thanks to the use of timing belts.

Spacers have to be fitted between the profiles every 1 meter to ensure a perfect parallelism of the profiles.

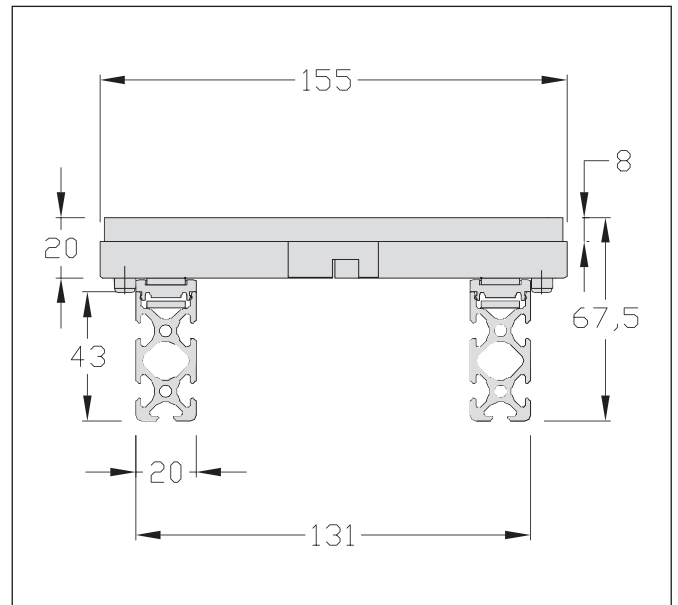

## Conveying unit 24 V, timing belt Width 150

### APPLICATION

Moving and accumulating of workpiece carriers 150x150.

The use of antistatic timing belts increases the load being transported and facilitates the maintenance when changing belts. Belt guides are pressed into aluminium profile housings. According to the load, longer spans can be

joined end to end by straight joinings. The cuttings of conveyors allow division of the lengths, making transport and installation lines easier.

The reassembly is greatly facilitated thanks to the use of timing belts.

Spacers have to be fitted between the profi-

les every meter to ensure a perfect parallelism of the two profiles.

This conveying unit is supplied with a Brushless motor factory-programmed according to your speed and acceleration ramp requirements. The use of a Brushless gear motor facilitates the wiring.

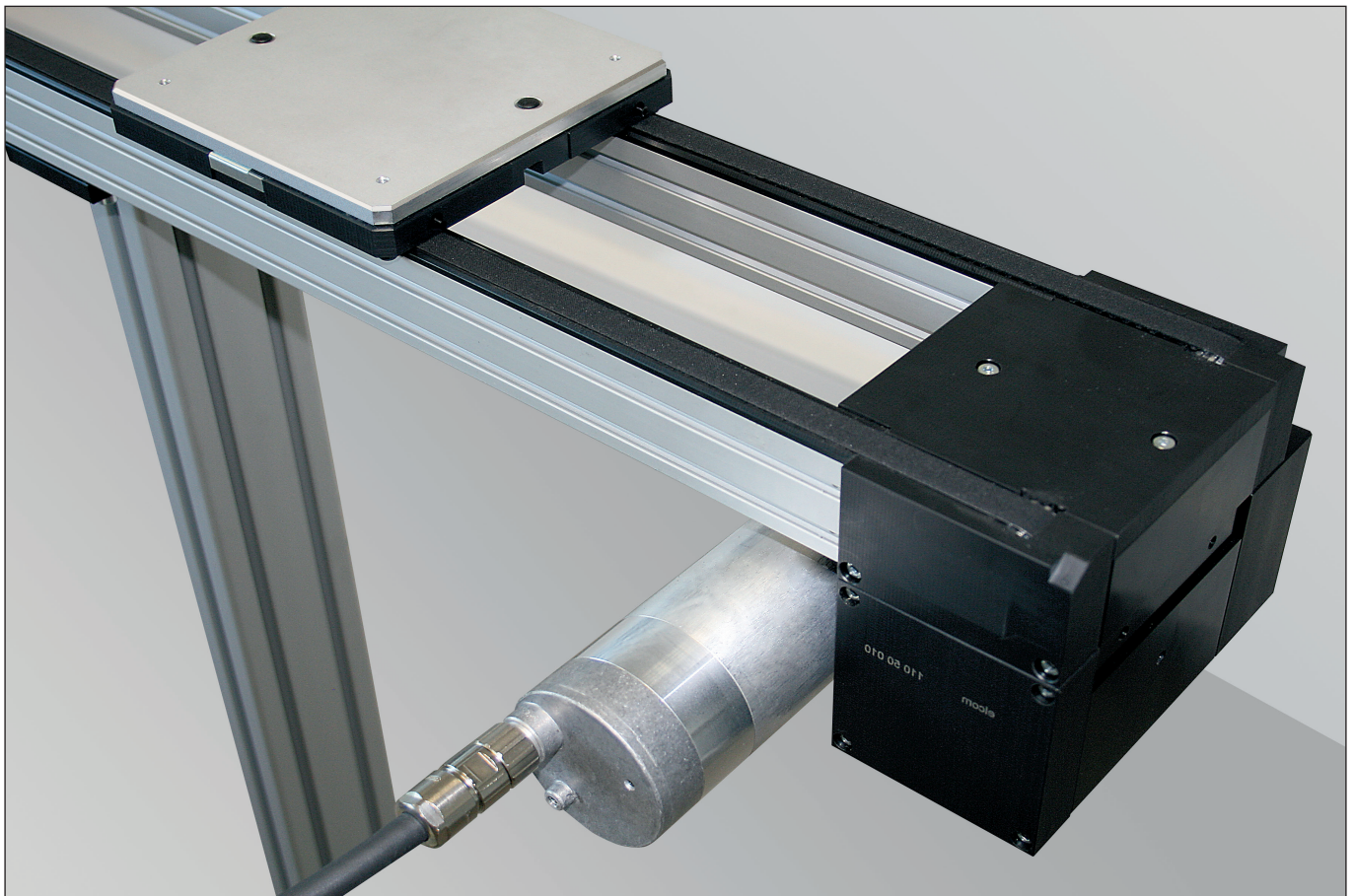

### NEW:

**This process allows to divide the electric consumption by 10 to 15.**



**elcom ITS 24 V**

## Conveying unit timing belt Width 150

### Technical data

Mini length L = 500 mm

Maxi length L = 3160 mm

For longer spans and according to the load, use several conveying units.

### Conveying unit including

- ✘ 1 idling unit
- ✘ 1 driving unit  
speed: 12 or 16 m/min
- ✘ 1 motor 380 V three-phase  
0,09 KW I: 0,4 A

### Conveyor length

- ✘ 2 profiles 5 43x20, al anodized
- ✘ 2 belt guides, PA black
- ✘ 2 antistatic timing belts  
width 12 mm, 5 mm step

Maximum load /3 m: 70 daN

Maximum accumulation load /3 m: 35 daN

### Belt length in mm

$$L_c = [(L-160) \times 2 + 526] \times 0,9995$$

Weight: 9,5 kg + 2,07 kg /m

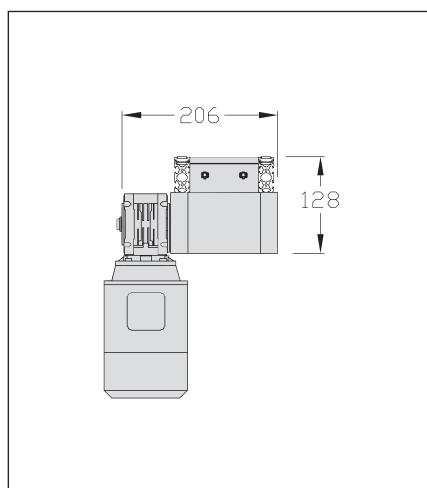
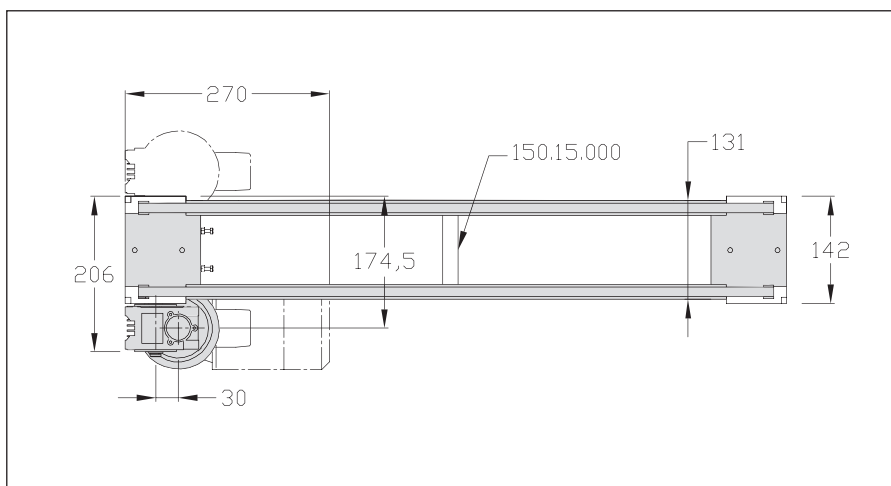
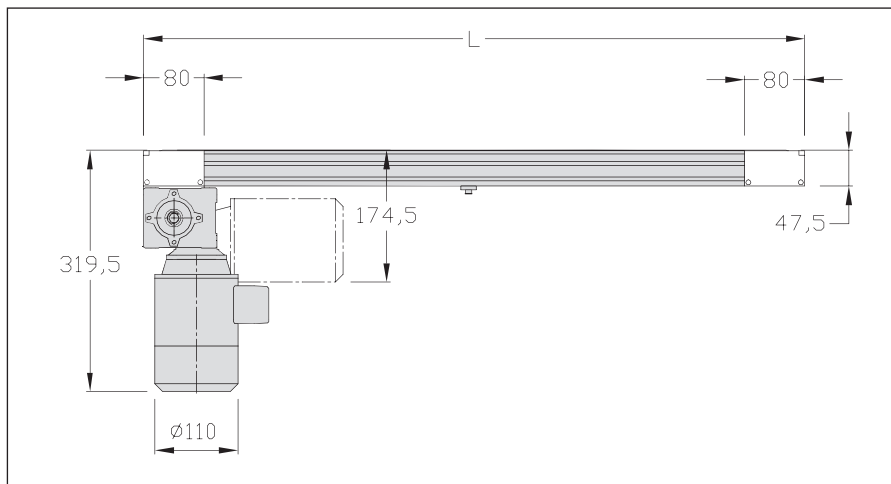

Designation / Dimensions	Order unit	Reference
Conveying unit 150 timing belt	1 pce	150.50.000.**
Conveying length	m	110.50.000.A

(\*\* = speed of motor m/min: 12 or 16 eg: 150.50.000.12)

# Conveying unit 24 V timing belt Width 150

## Technical data

Mini length L = 500 mm

Maxi length L = 3160 mm

For longer spans and according to the load, use several conveying units.

## Conveying unit including

- ✗ 1 idling unit
- ✗ 1 driving unit  
speed: 9 to 19 m/min  
programmable en usine,
- ✗ 1 motor 24 V  
0,09 KW  
I: minimum supply voltage 5 A

## Conveyor length

- ✗ 2 profiles 5 43x20, al anodized
- ✗ 2 belt guides, PA black
- ✗ 2 antistatic timing belts  
width 12 mm, 5 mm step

Maximum load /3 m: 70 daN

Maximum accumulation load /3 m: 35 daN

## Belt length in mm

$$L_c = [(L-160) \times 2 + 526] \times 0,9995$$

Power supply: 24 VDC

Supply current: 8,5 A

Control voltage: 24 VDC

Control current: 10 mA

2 control outputs

2 status inputs

 A straight or angled connector is required

Electrical connection: see detailed specification sheet included with the material.

Weight : 8 kg + 2,07 kg /m

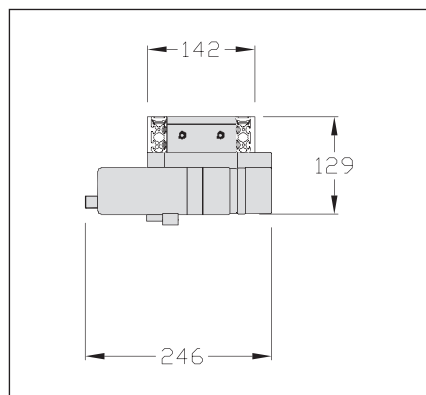
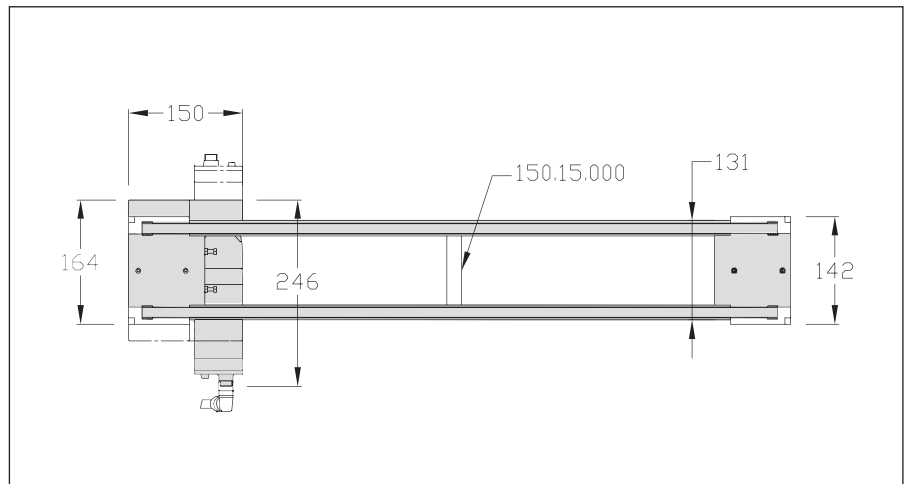
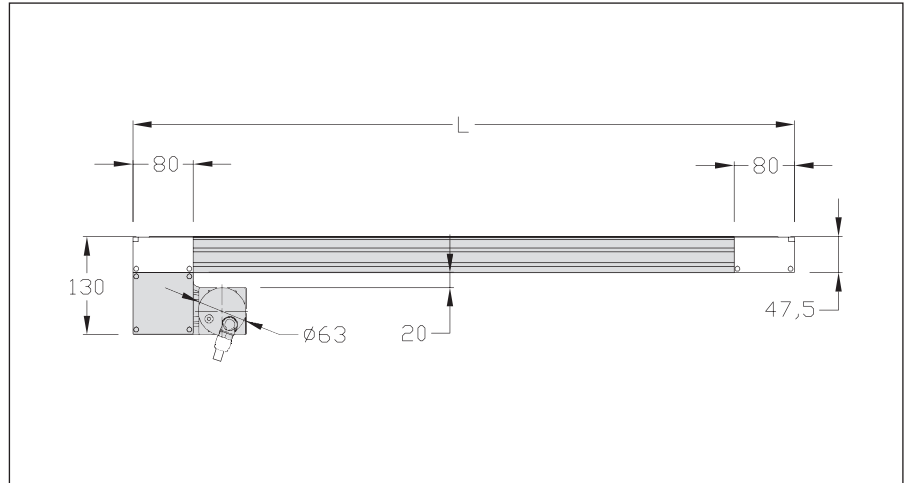

**elcom ITS 24 V**

TLM 1500

Designation / Dimensions	Order unit	Reference
Conveying unit 24 V 150 timing belt Motor Crouzet right	1 pce	150.50.000.EDC
Conveying unit 24 V 150 timing belt Motor Crouzet left	1 pce	150.50.000.EGC
Conveying unit 24 V 150 timing belt Motor Papst right	1 pce	150.50.000.EDP
Conveying unit 24 V 150 timing belt Motor Papst left	1 pce	150.50.000.EGP
Conveying length	m	110.50.000.A



## Spacer Width 150

### APPLICATIONS

Spacers have to be fitted every 1 meter to ensure a perfect parallelism of profiles.

#### Technical data

✘ 1 aluminium part + fastening parts

Weight: 0,065 kg

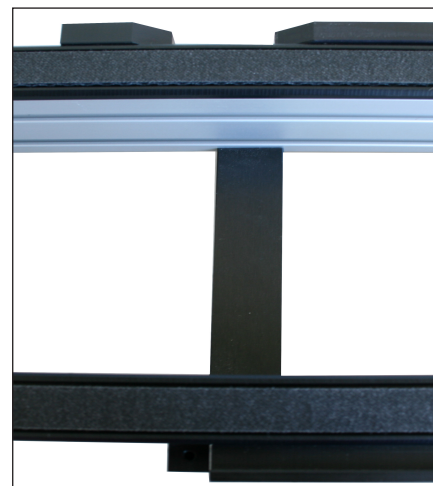
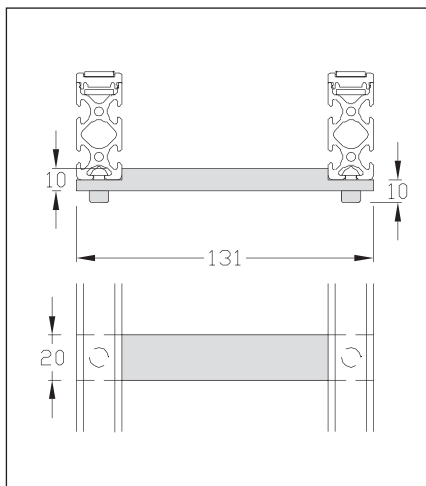

Designation / Dimensions	Order unit	Reference
Spacer 150	1 pce	150.15.000

## Caps Width 150

### APPLICATIONS

Allow to protect the direct driving and the idling unit.

When using a cam, the opposite cap is delivered with the cam set.

#### Technical data

Cap for motorization 100 adapt themselves on the motorization 150.

#### Cap for motorization

✘ 1 part + 1 symmetrical part, PA black + fastening parts

#### Cap for idling unit

✘ 1 part and 1 symmetrical part, PA black + fastening parts

Weight: 0,07 kg

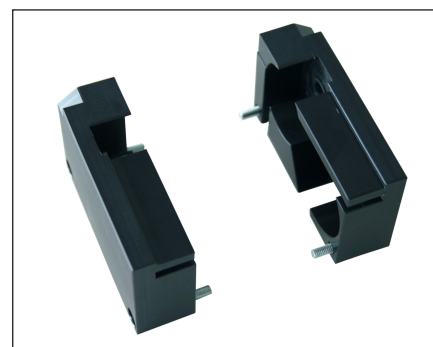
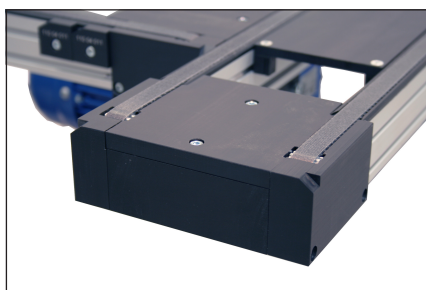
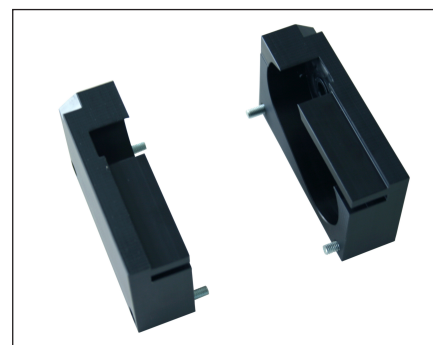
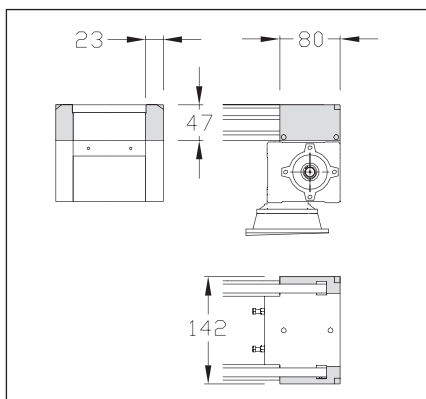

Designation / Dimensions	Order unit	Reference
Cap for motorization 150 timing belt	1 set	110.50.100
Cap for idling unit 150 timing belt	1 set	110.50.200

## Straight joining Width 150

### APPLICATIONS

Allow to butt end to end two conveying units.

#### Technical data

- x** Guide PA black
- x** Joining set aluminium

Weight: 0,16 kg

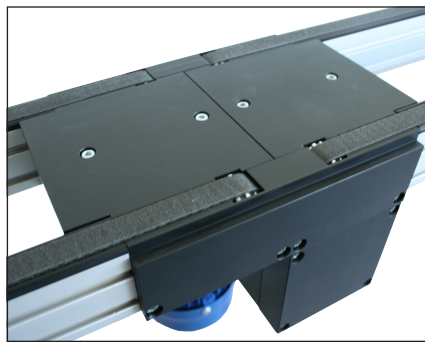
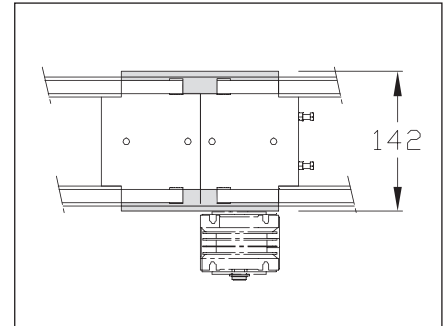
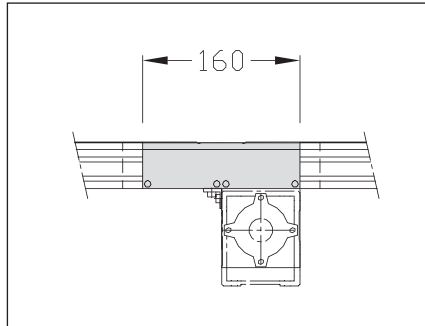

Designation / Dimensions	Order unit	Reference
Straight joining 150 timing belt	1 set	150.52.000

## Conveying unit stand

### APPLICATIONS

Support to fit conveying units on table or frame.

Weight: 0,77 kg

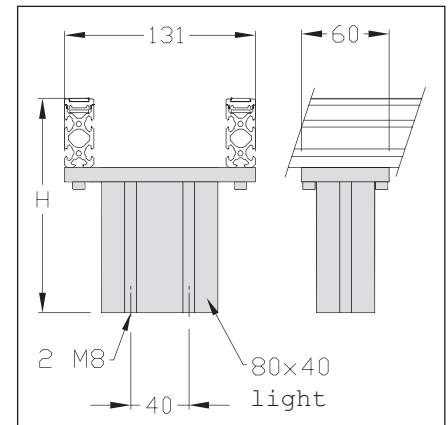

Designation / Dimensions	Order unit	Reference
Conveying unit stand 150	1 set	150.16.000

## Cams 90°

### APPLICATIONS

**The cams ED, EG, SD, SG** allow a perpendicular transfer of workpiece carriers from one conveying unit to the other without automatism.

The workpiece carrier is guided by the two inner pins, the outside pins are retracted.

They are also used for derivations.

Do not accumulate the workpiece carriers in the cams.

For a good operating, the workpiece carrier coming in the cam mustn't be pushed by other workpiece carriers.

#### **Short cams SD-EG SG-ED-Double cams**

The short cams and the double cams allow deviation of workpiece carriers from a main line to a secondary line without additional motorization.

Economical, compact and very easily managed, they are ideal to set up work stations in derivation.

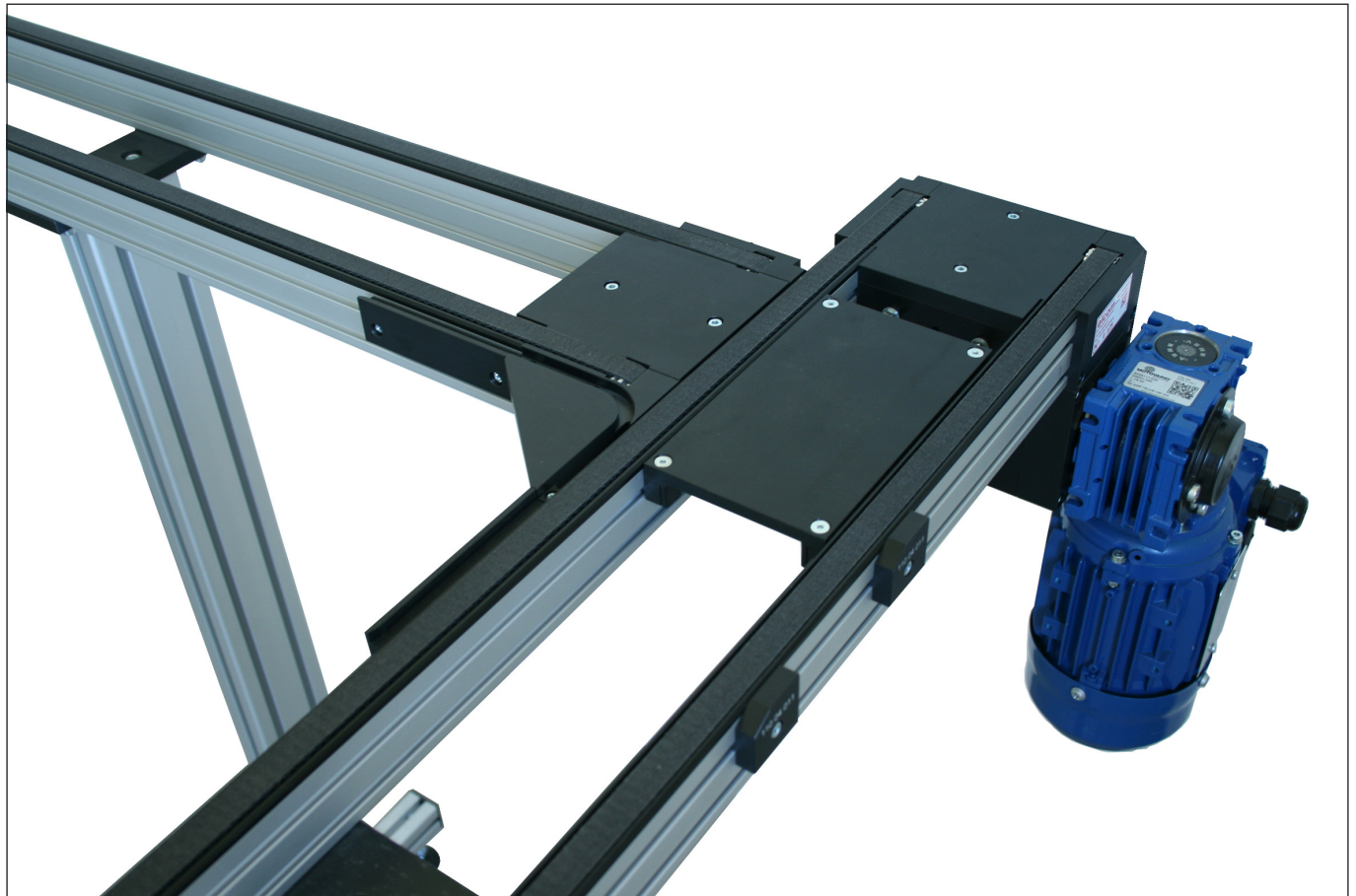

## Cams 90° Width 150

### Technical data

Complete set including:

- ✘ Guiding cam and pin retracting plates, PA black
- ✘ Fastening parts
- ✘ Joining parts
- ✘ A cap for motorization or for idling unit

If a selection is necessary (derivation or not), add the derivation set.

Lp = workpiece carrier length

Weight:

Cams ED and EG: 0,50 kg

Cams SD and SG: 0,44 kg

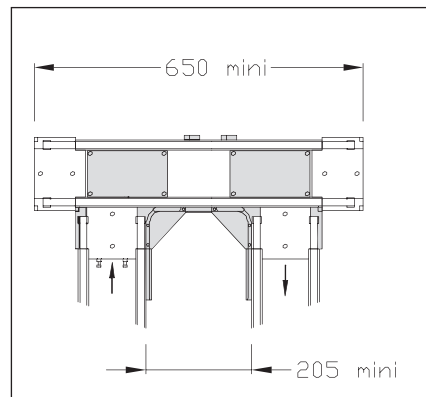
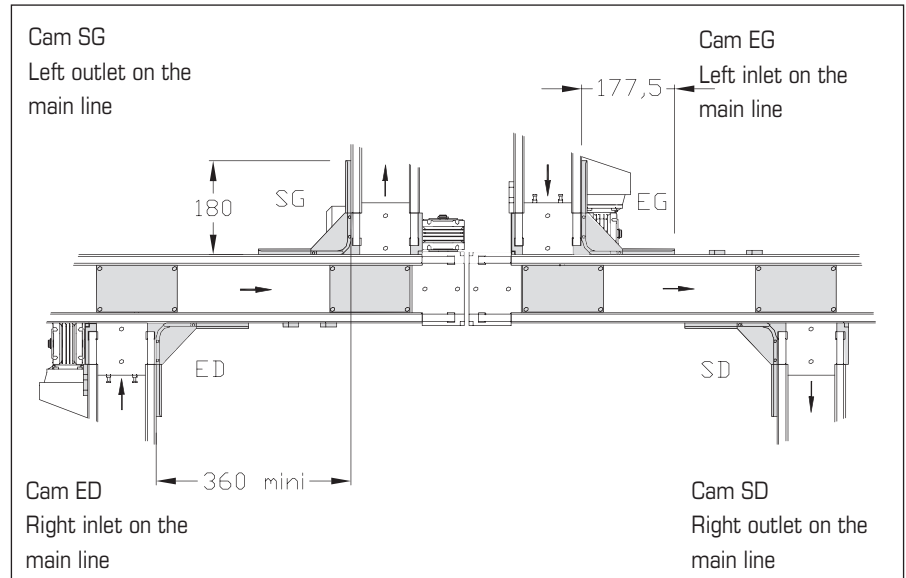

Designation / Dimensions	Order unit	Reference
<b>Cams 90° ED 150</b>	<b>1 set</b>	<b>150.53.100</b>
<b>Cams 90° EG 150</b>	<b>1 set</b>	<b>150.53.200</b>
<b>Cams 90° SD 150</b>	<b>1 set</b>	<b>150.53.300</b>
<b>Cams 90° SG 150</b>	<b>1 set</b>	<b>150.53.400</b>

## Derivations Width 150

### APPLICATIONS

Derivations have to be used with a cam. They allow potential diversion or not of the workpiece carrier by retraction of the pins on one side or the other of the conveyor.

The two cylinders are controlled by only one solenoid valve.

### Technical data

Complete set including:

- ✘ 2 plates Al
- ✘ 2 nuts 5 St M4
- ✘ 2 screws M4x10
- ✘ Body, levers and guides PA
- ✘ 2 cylinders  $\varnothing$  16-5 M5, detectable positions



Cams are not included (must be ordered separately).

Weight: 0,4 kg

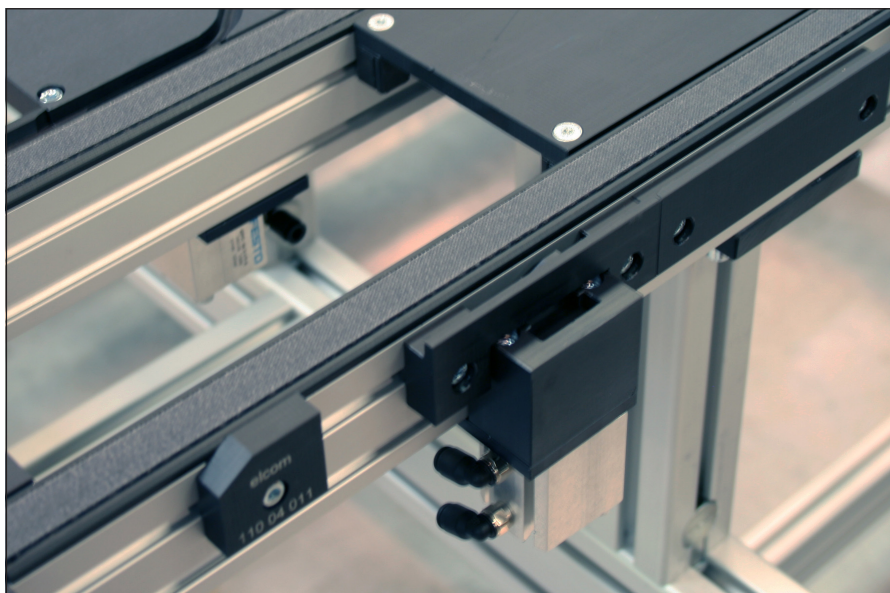
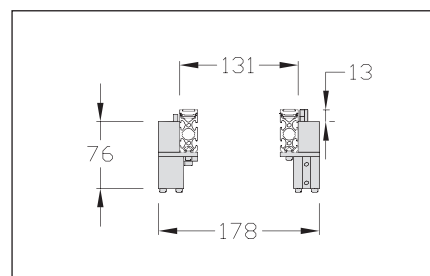
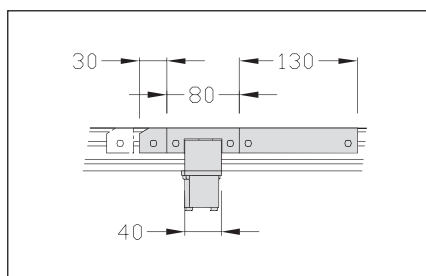
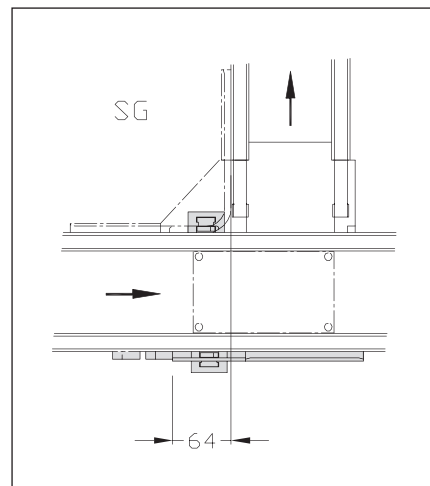
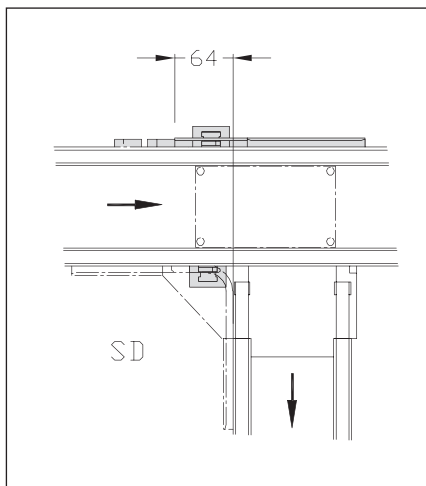

Designation / Dimensions	Order unit	Reference
Derivation 150 SD	1 set	150.07.000
Derivation 150 SG	1 set	150.13.000



## Derivations 24 V Width 150

### APPLICATIONS

Necessarily combined with a cam, they allow the deviation of workpiece carriers, or not, by retracting the pins on one side or the other of the conveyor.

2 Brushless gear motors controlled by a control box ensure the movement.

A single output for logic controller is necessary.

Control module 24 V output: automation, bus module, splitter...

Standard connectors M12.

An extension for connection M8 male/female 3 pins between the motor and the control box is required.

### Technical data

Complete set including:

- ✗ 2 plates Al
- ✗ 2 nuts 5 St M4
- ✗ 2 screws M4x10
- ✗ Body, levers and guides PA
- ✗ 2 servomotors

 Cams are not included (must be ordered separately).

Supply voltage of of the control box:

24 volt +/- 15%

Power supply: 1,6 A maxi

Control voltage: 24 volt +/- 10 %

Control current: 5 mA maxi

Electrical connection: see detailed specification sheet included with the material.

Weight: 0.8 kg

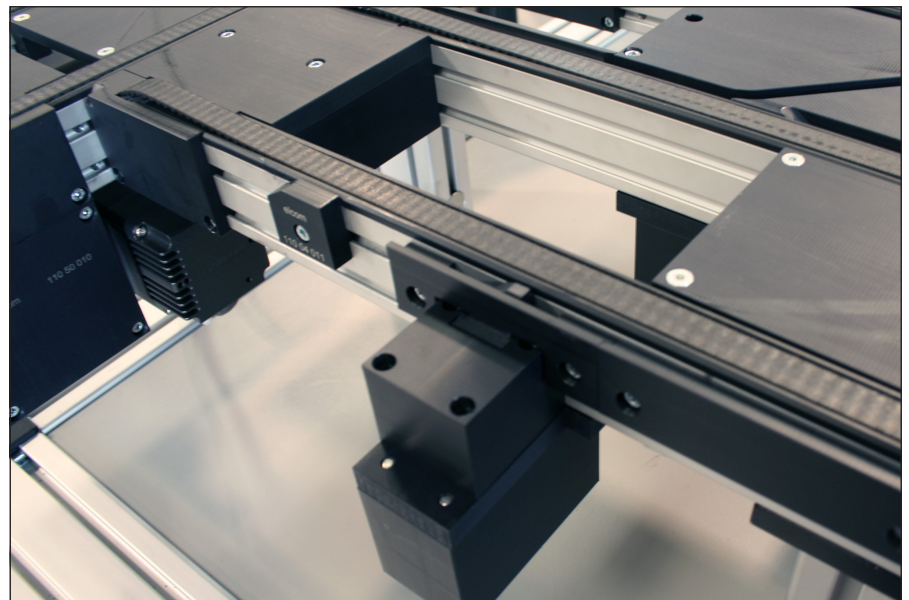
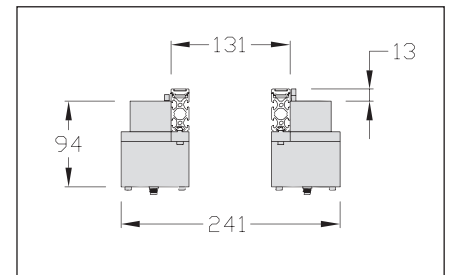
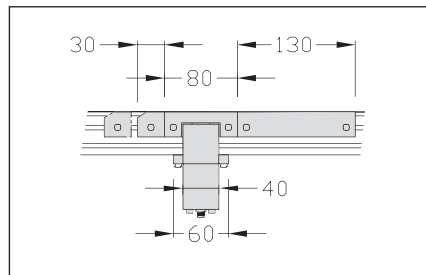
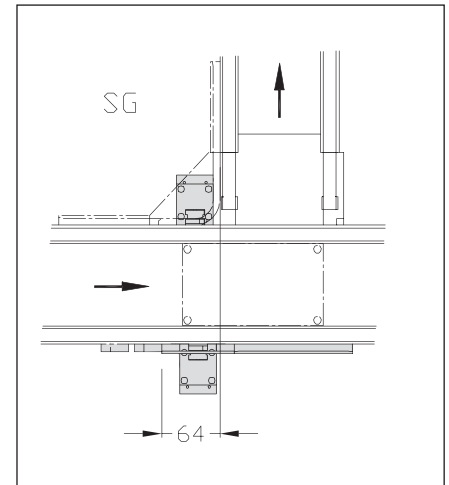
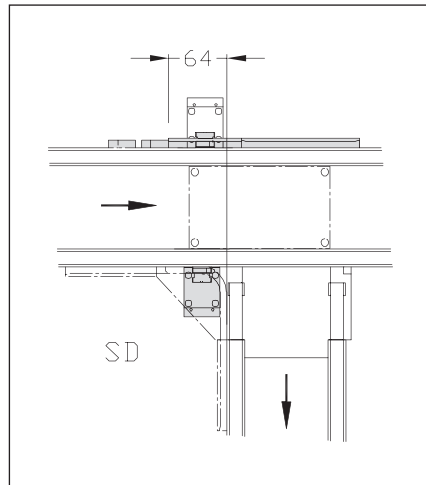

elcom ITS 24 V

Designation / Dimensions	Order unit	Reference
Derivation 24 V 150 SD	1 kit	150.07.000.E
Derivation 24 V 150 SG	1 kit	150.13.000.E

## Stoppers, simple - double effect Width 150

### APPLICATIONS

They stop workpiece carriers during processing requiring no accuracy.

They are perfectly adapted for manual work stations.

Management of workpiece carriers in order to respect conveying priorities at the end of the derivation.

Stopper simple or double effect, supplied with lateral guides, sensor bracket for detection of workpiece carriers.

The anti bouncing back is integrated in the lateral guides.

### Technical data

- ✗ Plate, al black
- ✗ Body and stopper PA
- ✗ Nuts 5 St M5 + screws
- ✗ Hole for shielded mounting sensor M12x100
- ✗ Detection range: 4 mm

Maximum load: 10 daN  
(in accumulation)



Flow rate controller M5 should be adapted.

Weight: 0,5 kg

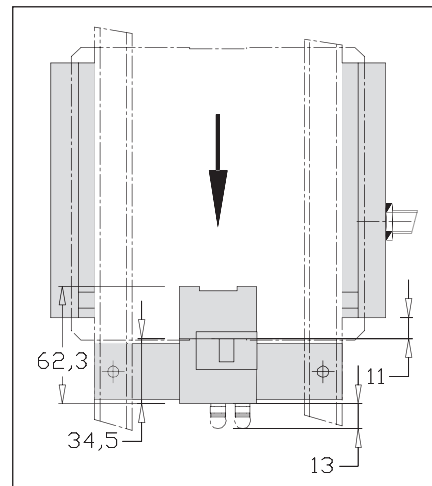
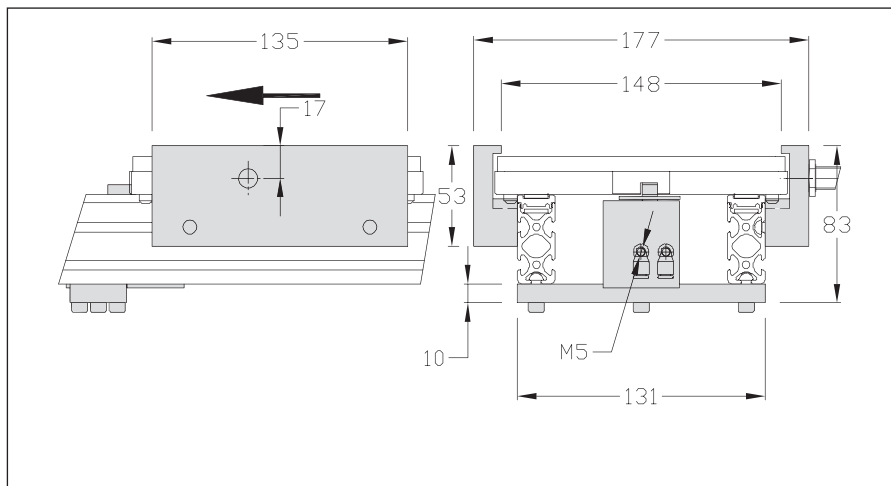

Designation / Dimensions	Order unit	Reference
Stopper 150 simple effect	1 pce	150.02.000
Stopper 150 double effect	1 pce	150.22.000

# Damped stopper, pneumatic Width 150

## APPLICATIONS

Stops workpiece carriers during processing requiring no accuracy.

It allows reducing the shock of workpiece carrier against the stoppers thanks to the adjustable pneumatic damping.

Pneumatic control of the stopper with spring return.

Stopper supplied with sensor bracket.

## Technical data

- ✘ Stopper
- ✘ Stopper bracket
- ✘ Sensor bracket
- ✘ Screws and nuts

Minimum load / workpiece carrier:  
12 - 16 m/min

Maximum load/workpiece carrier (workpiece carrier included):

- 7.5 kg to 16 m/min
- 9 kg to 12 m/min

Air consumption: 0,036 l to 6 bars.  
Operating pressure: 4 to 8 bars.

Longitudinal damping stroke: 7 mm

 1 connection M5 is required.

Weight :1.06 kg

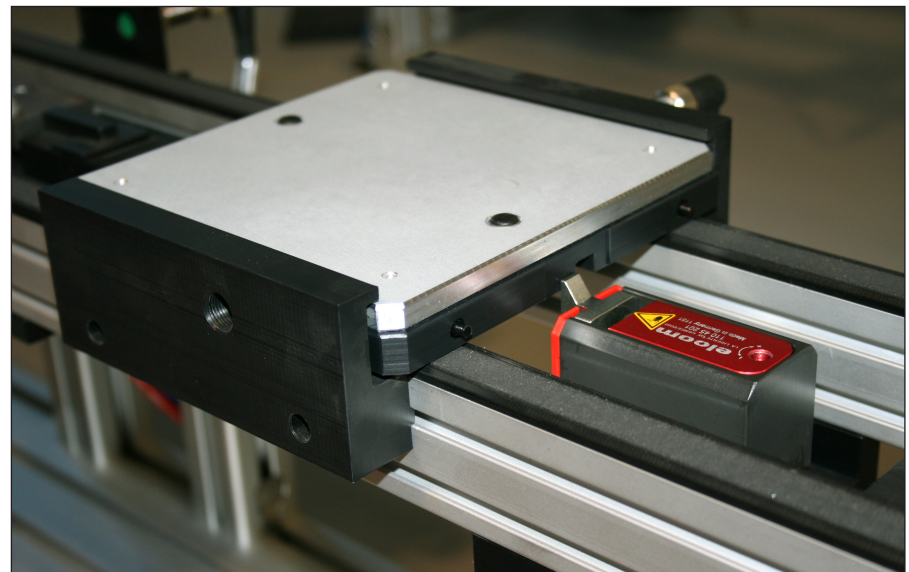
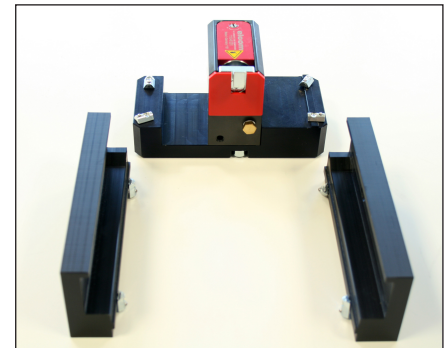
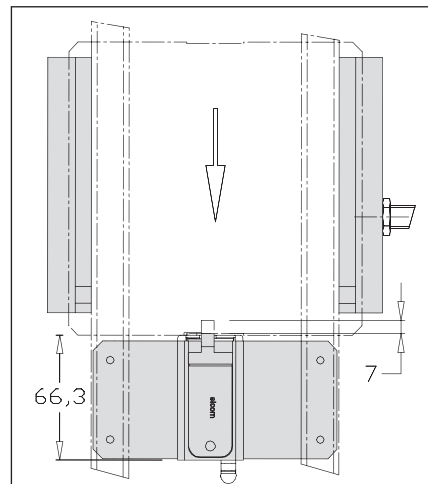
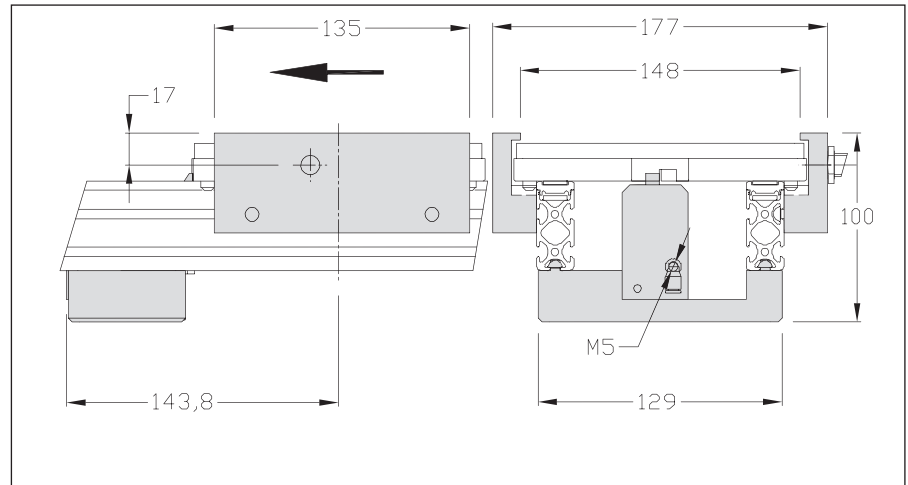

Designation / Dimensions	Order unit	Reference
Damped stopper 150 pneumatic	1 pce	150.45.000.RAP

## Stopper 24 V Width 150

### APPLICATIONS

It stops workpiece carriers requiring no accuracy during processing, perfectly adapted to manual work stations.

Workpiece carriers are stopped to respect conveying priorities at the end of the derivation.

Simple effect stopper with spring return. Supplied with lateral guides and sensor bracket for the detection of workpiece carriers.

1 servomotor controlled by a control box ensures the change in position.

A single output for logic controller is necessary.

Control module 24 V output: automation, bus module, splitter...

Standard connectors M12.

An extension for connection M8 male/female 3 pins between the stopper and the control box is required.

The anti-bouncing back part is integrated into the lateral guides.



**elcom ITS 24 V**

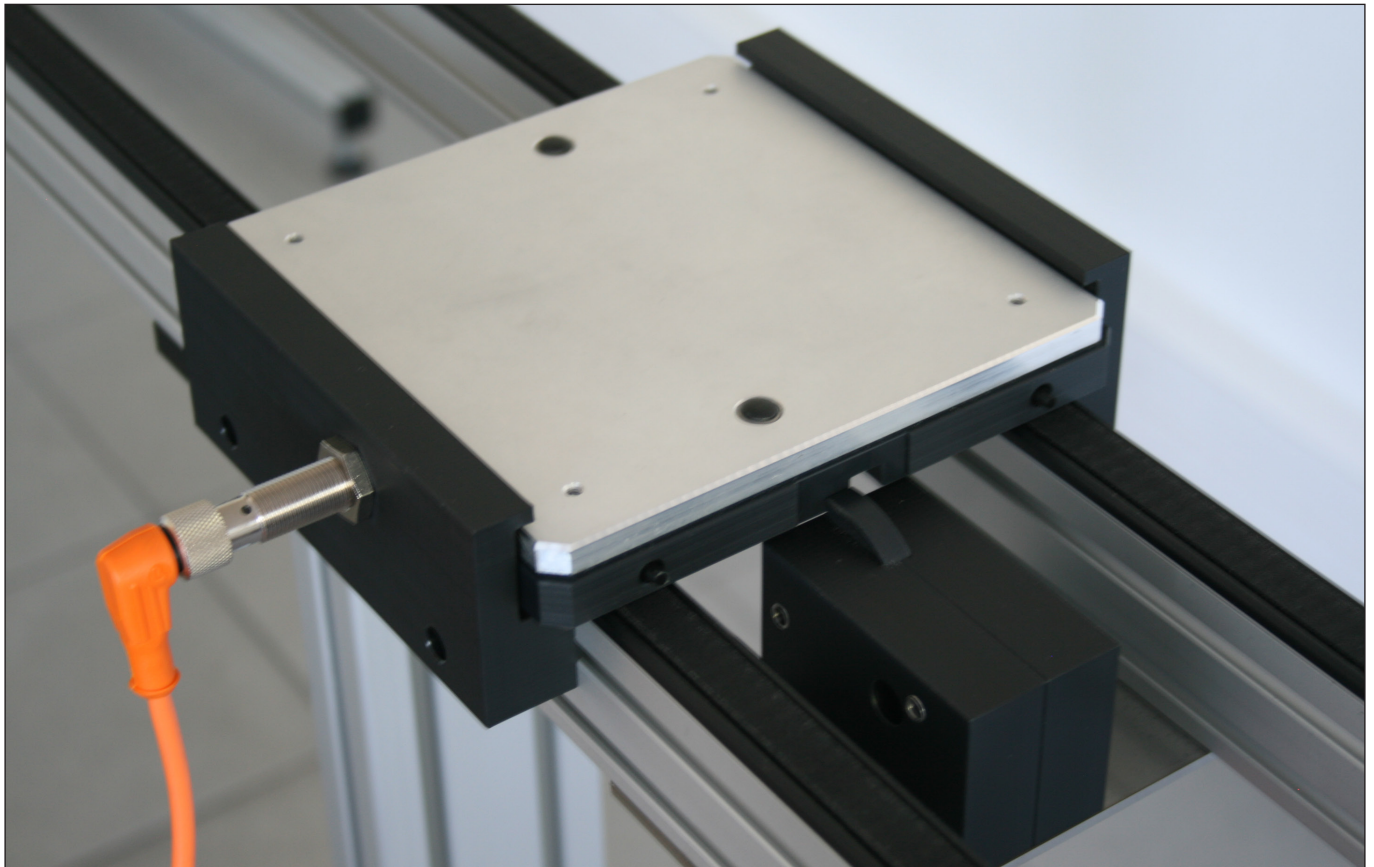



### Technical data

- ✘ Plate, stainless steel
- ✘ Body and stopper PA
- ✘ Nuts 5 St M5 + screws
- ✘ Hole for shielded sensor M12x100
- ✘ Detection range: 4 mm

Supply voltage of the control box:

24 VDC +/- 15%

Maximum power supply: 0.9 A

Control voltage: 24 VDC +/- 10 %

Control current: 5 mA maxi

Maximum load: 20 daN (in accumulation)

Electrical connection: see detailed specification sheet included with the material.

Weight: 0.75 kg

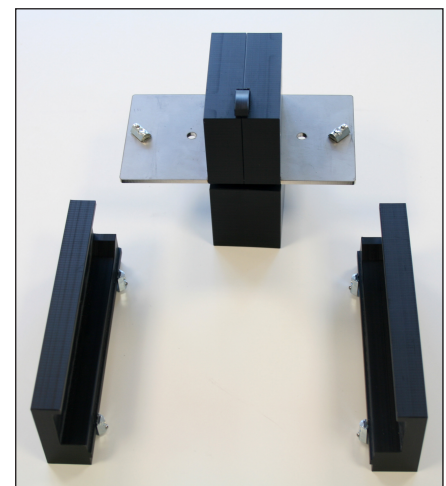
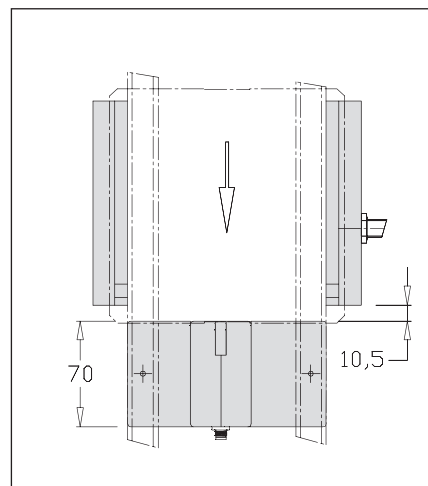
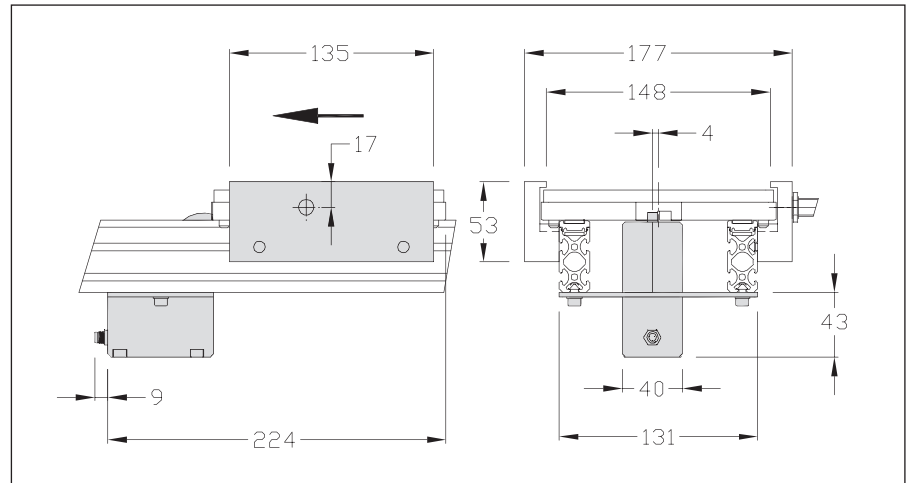

elcom ITS 24 V

Designation / Dimensions	Order unit	Reference
Stopper 24 V 150	1 pce	150.02.000.E



## Positioning units

The positioning unit is directly fitted on the conveying units.

2 possibilities: stopper simple effect and stopper double effect.

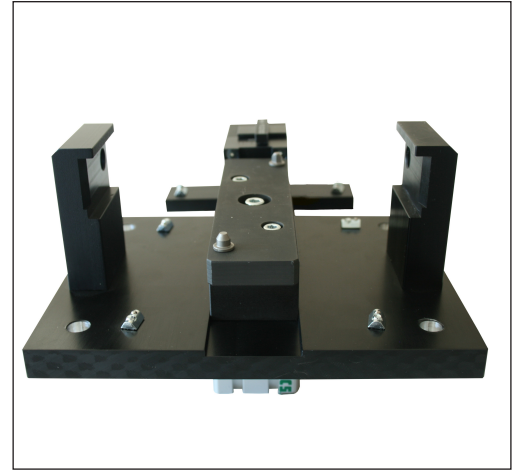

## Positioning unit, damped pneumatic stopper

It is directly fitted on the conveying units.

Shocks are reduced between the workpiece carrier and the stopper thanks to the adjustable damped function.

Pneumatic control of the stopper, spring return.

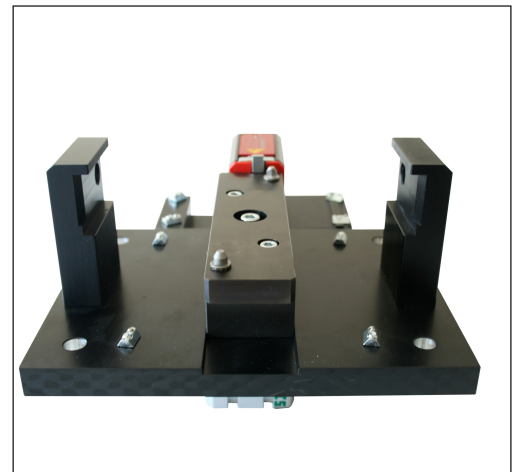

## Positioning units for station

They are settled on a table or a frame to ensure accuracy with the other surrounding elements.

A positioning set is necessary for operations requiring accuracy.

2 possibilities: simple effect stopper and double effect stopper.

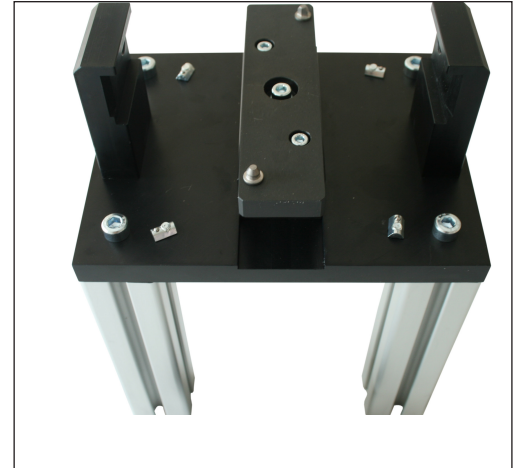

## Positioning unit for station, damped pneumatic stopper

It is fixed to a table or a frame to ensure accuracy with the other peripheral elements.

A positioning kit is required for accurate operations.

Shocks are reduced between the workpiece carrier and the stopper thanks to the adjustable damped function.

Pneumatic control of the stopper, spring return.

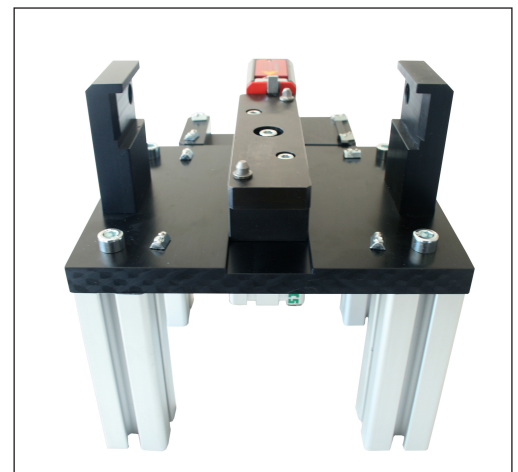

## Positioning unit for station 24 V, automatic stopper



It is fixed to a table or a frame to ensure accuracy with the other peripheral elements.

A positioning kit is required for accurate operations.

The stopper of workpiece carriers is positioned by the vertical movement (no stopper control needed).

A Brushless gear motor ensures the control of the stopper and the positioning unit.

Irreversible system.

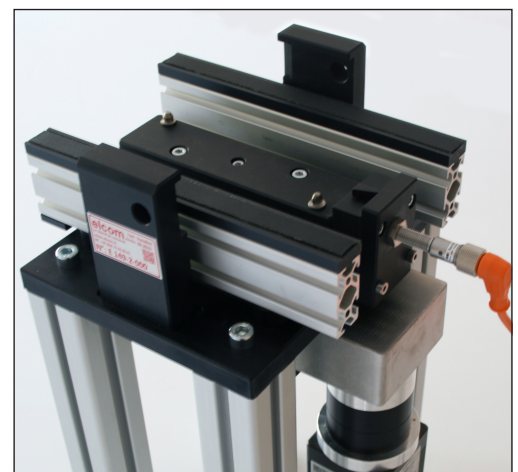

## Lift positioning units

Stop and positioning of workpiece carriers at a significant height above the conveyor.

The workpiece carrier is stopped, then elevated to a specific height, while being held by two centering pieces.

An upstream stopper is required.

2 possibilities: simple effect stopper and double effect stopper.



## Lift positioning unit, damped pneumatic stopper

Stops and positions workpiece carriers at a significant height above the conveyor.

The workpiece carrier is stopped, centered by 2 specific parts and then lifted.

Shocks are reduced between the workpiece carrier and the stopper thanks to the adjustable damped function.

An upstream stopper is required due to the lifting of the workpiece carrier (not supplied).

Pneumatic control of the stopper, spring return.

The dead man's option is used to lock the lift positioning unit in case of air cut-off and therefore avoids the lowering of the load.

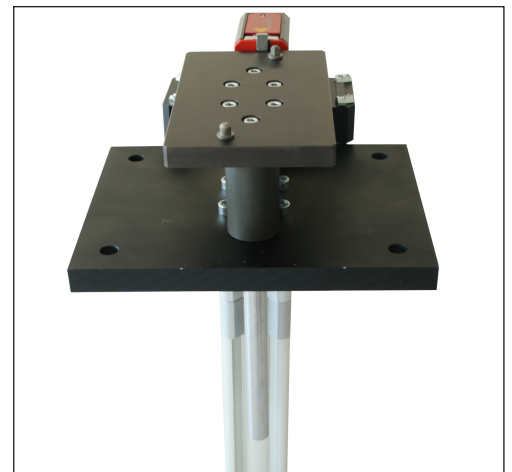

## Positioning units Width 150

### Technical data

Complete set including:

- ✘ Stopper
- ✘ Positioning unit
- ✘ 1 double effect cylinder  $\varnothing$  32, detectable positions
- ✘ Holes for shielded mounting sensor M12x100
- ✘ Detection range: 4 mm

Maximum vertical strain: 40 daN for a pressure of 6 bars

Repeatability: +/- 0,03 mm

2 possibilities:

Stiopper simple effect or stopper double effect



2 flow rate controllers G 1/8 for positioning unit cylinder and controllers for the stopper should be adapted.

Weight: 4,3 kg

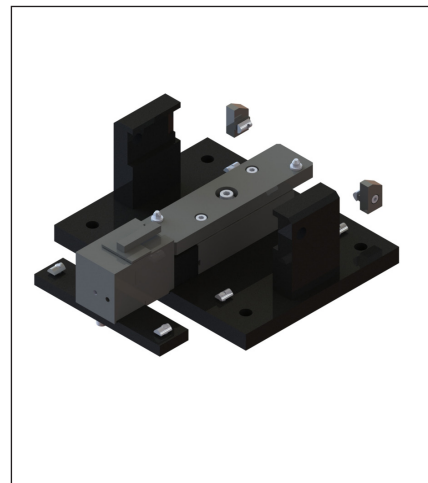
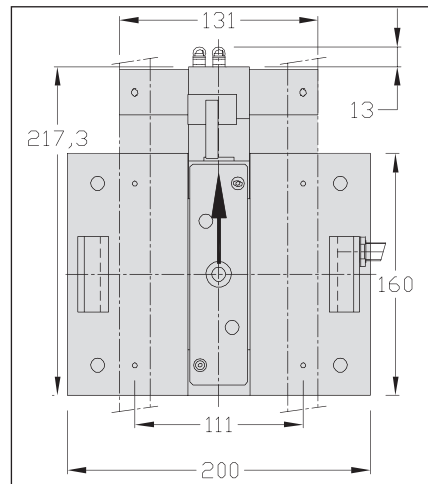
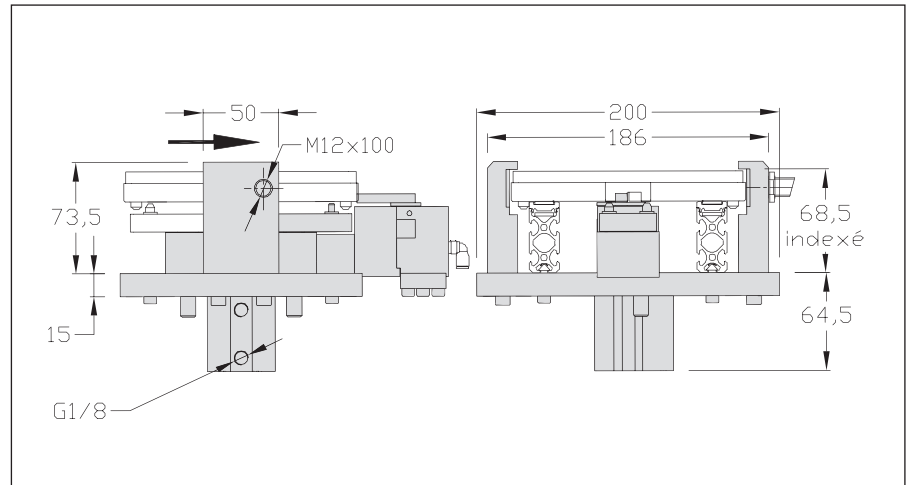

Designation / Dimensions	Order unit	Reference
Positioning unit 150 simple effect	1 pce	150.24.000
Positioning unit 150 double effect	1 pce	150.25.000

## Positioning unit, damped pneumatic stopper Width 150

### Technical data

Complete set including:

- ✘ Stopper
- ✘ Positioning unit
- ✘ 1 double effect cylinder  $\varnothing$  32, detectable positions
- ✘ Holes for shielding mounting sensors M12x100
- ✘ Detection range: 4 mm

Maximum vertical strain: 40 daN to 6 bars

Repeatability: +/- 0,03 mm

 2 flow rate controllers G 1/8 for the cylinder of the positioning unit + 1 connection M5 for the stopper are required.

Weight: 3.6 kg

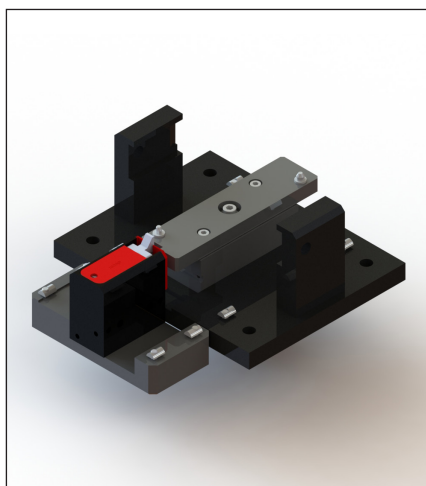
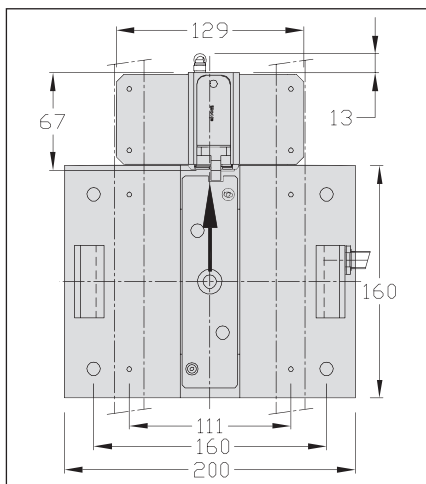
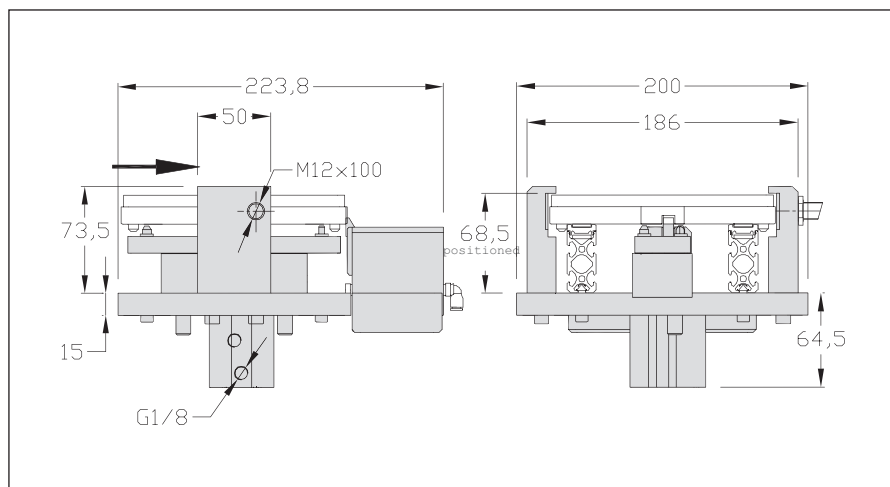

**Designation / Dimensions**

**Positioning unit 150, damped pneumatic stopper**

**Order unit**

**1 pce**

**Reference**

**150.24.000.RAP**



## Positioning units for station Width 150

### Technical data

Complete set including:

- ✘ Stopper and positioning unit
- ✘ 1 double effect cylinder  $\varnothing 32$ , detectable positions
- ✘ Holes for shielded mounting sensor M12x100
- ✘ Detection range: 4 mm
- ✘ 4 feet in profile 40x40
- ✘ Fastening elements

Maximum vertical strain: 40 daN for a pressure of 6 bars

Repeatability:  $\pm 0,03$  mm



2 flow rate controllers M5 and G 1/8 for positioning unit cylinder and controllers for the stopper should be adapted.

Weight: 4,3 kg

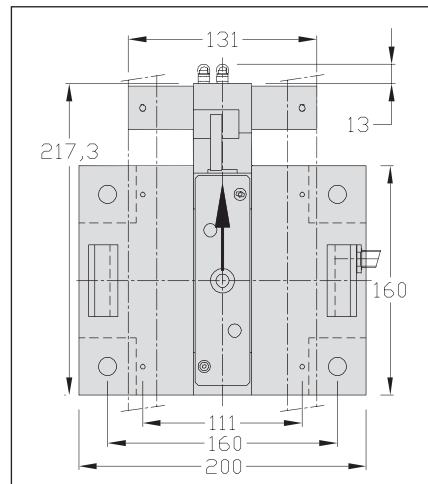
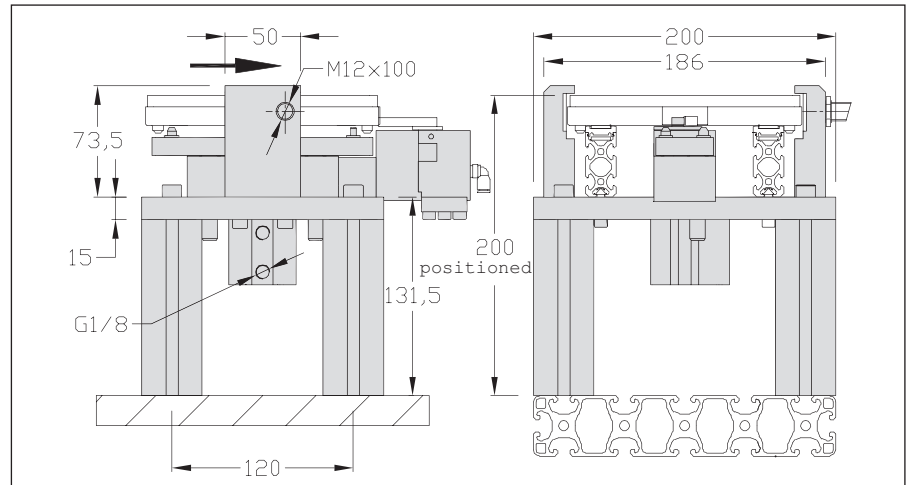

Positioning unit for station 150  
with simple effect and double effect

Designation / Dimensions	Order unit	Reference
Positioning unit for station 150 simple effect	1 pce	150.26.000
Positioning unit for station 150 double effect	1 pce	150.27.000

## Positioning unit for station, damped pneumatic stopper Width 150

### Technical data

Complete set including:

- x Stopper
- x 1 double effect cylinder ø 32, detectable positions
- x Holes for shielding mounting sensors M12x100
- x Detection range: 4 mm
- x 4 profile stands 8 40x40
- x Fastening parts

Maximum vertical strain: 40 daN to 6 bars

Repeatability: +/- 0,03 mm



2 flow rate controllers G1/8 for the cylinder of the positioning unit + flow rate controllers for the stopper are required.

Weight: 4.6 kg

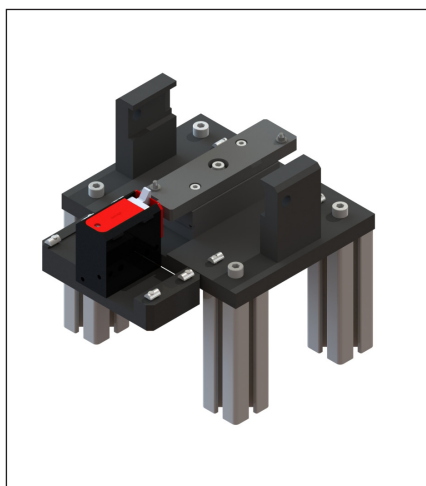
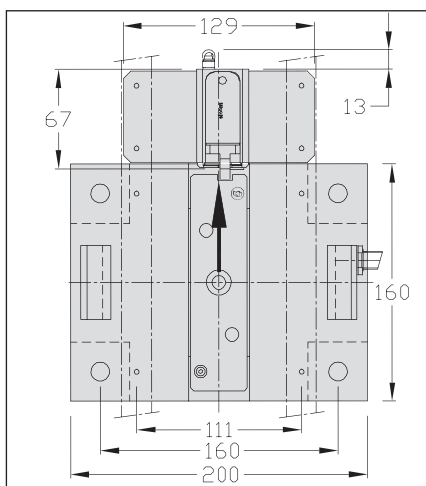
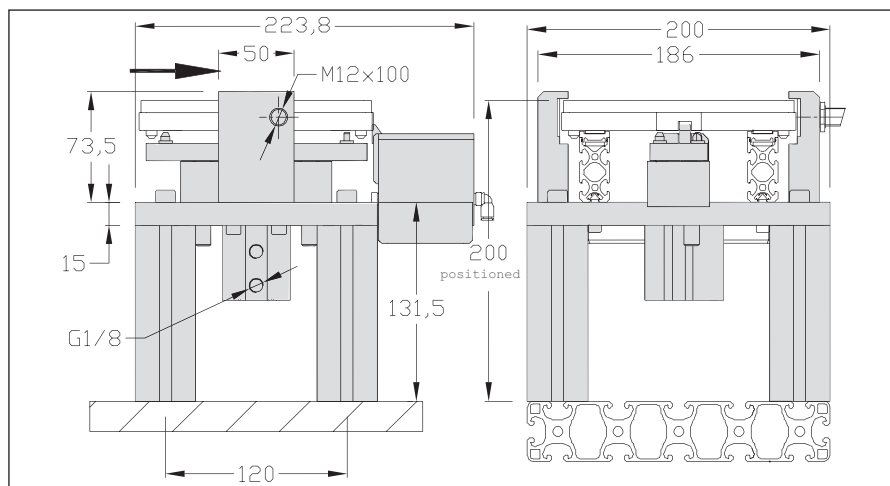

**Designation / Dimensions**

**Positioning unit for station 150 damped pneumatic stopper**

**Order unit**

**1 pce**

**Reference**

**150.26.000.RAP**

# Positioning unit for station 24 V Automatic stopper Width 150

## Technical data

Complete set including:

- ✘ 1 gear motor 24 V
- ✘ Vertical movement provided by an irreversible screw-nut system
- ✘ Vertical position controlled by encoder
- ✘ Housing for shielded mounting sensors M12X100
- ✘ Detection range: 4 mm
- ✘ 4 profile stands 8 40x40
- ✘ Fastening parts

Maximum vertical strain: 100 daN

Repeatability: +/- 0.03 mm

Motor supply voltage: 24 VDC

Motor supply current: 4 A

Control voltage: 24 VDC

Control current: 10 mA

5 positioning input status

4 output status

The stopper of workpiece carriers is positioned by the vertical movement (no stopper control needed).

A Brushless gear motor ensures the control of the stopper and the positioning unit.

Irreversible system.

Electrical connection: see detailed specification sheet included with the material.

Weight: 7.5 kg

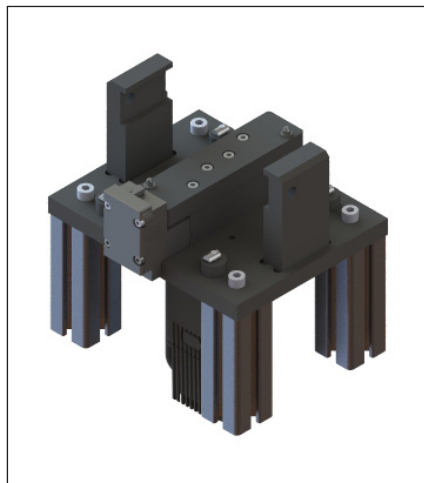
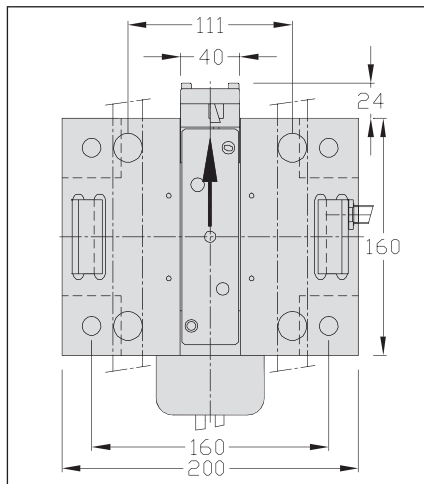
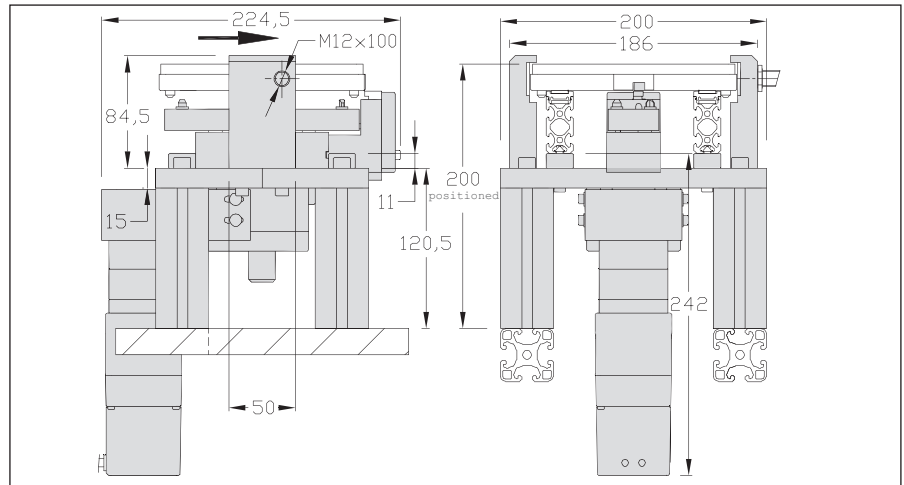

**elcom ITS 24 V**

TLM 1500

Designation / Dimensions	Order unit	Reference
Positioning unit for station 24 V 150 Automatic stopper	1 pce	150.10.000.E

## Lift positioning units Width 150

### Technical data

Complete set including:

- ✘ Impulse controlled stopper and anti bouncing back devices
- ✘ 1 double effect cylinder  $\varnothing 32$
- ✘ Ball bearing guide bush  $\varnothing 14$
- ✘ 1 bracket support for shielded mounting sensor M12x100
- ✘ Detection range: 4 mm

Available cylinder strokes:

25 - 50 - 100 - 160 - 200 mm

Maximum vertical strain: 40 daN

Repeatability: +/- 0,06 mm



A stopper located before the lift unit is generally necessary to avoid the arrival of another workpiece carrier during lifting.



2 flow rate controllers G 1/8 for positioning unit cylinder and controllers M5 for the stopper should be adapted.

Weight: 4,6 kg

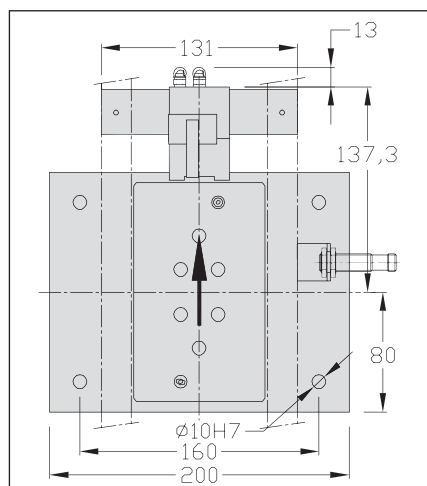
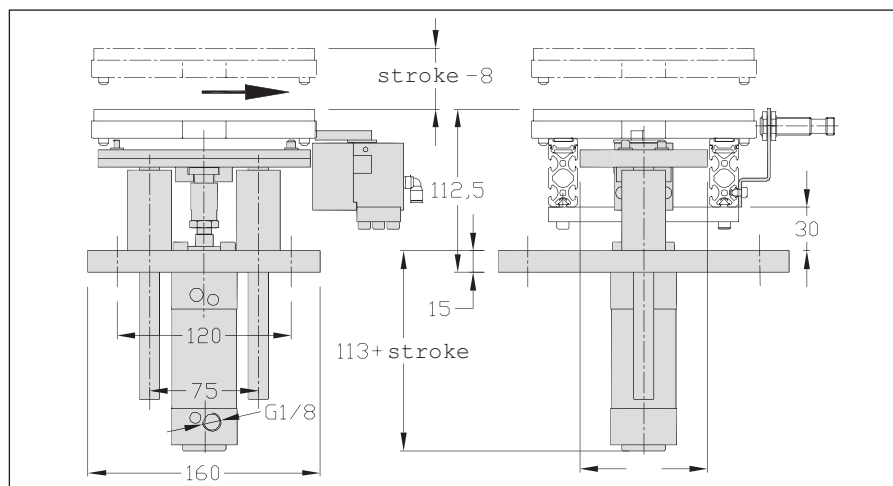

### Designation / Dimensions

Lift positioning unit 150 simple effect

Lift positioning unit 150 double effect

### Order unit

1 pce

1 pce

### Reference

150.12.000

150.31.000

# Lift positioning unit, damped pneumatic stopper Width 150

## Technical data

Complete set including:

- ✘ Stopper
- ✘ 1 double effect cylinder  $\varnothing$  32
- ✘ 1 ball bearing guide bush  $\varnothing$  14
- ✘ 1 bracket for shielded mounting sensor M12x10
- ✘ Detection range: 4 mm

Available cylinder strokes:  
25 - 50 - 100 - 160 - 200 mm

Maximum vertical strain: 40 daN

Repeatability: +/- 0,06 mm



An upstream stopper is required to prevent the inlet of a workpiece carrier during the lifting.



2 flow rate controllers G 1/8 for the cylinder of the positioning unit + 1 connection M5 for the stopper are required.

Weight: 5 kg

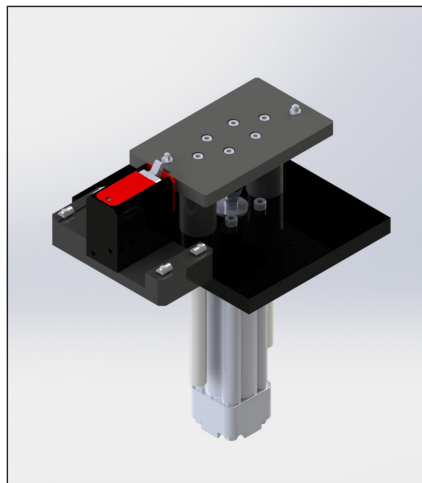
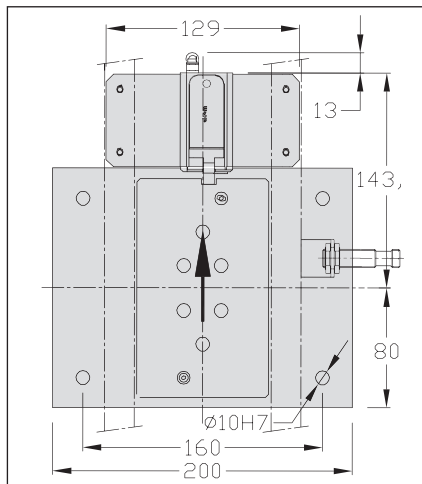
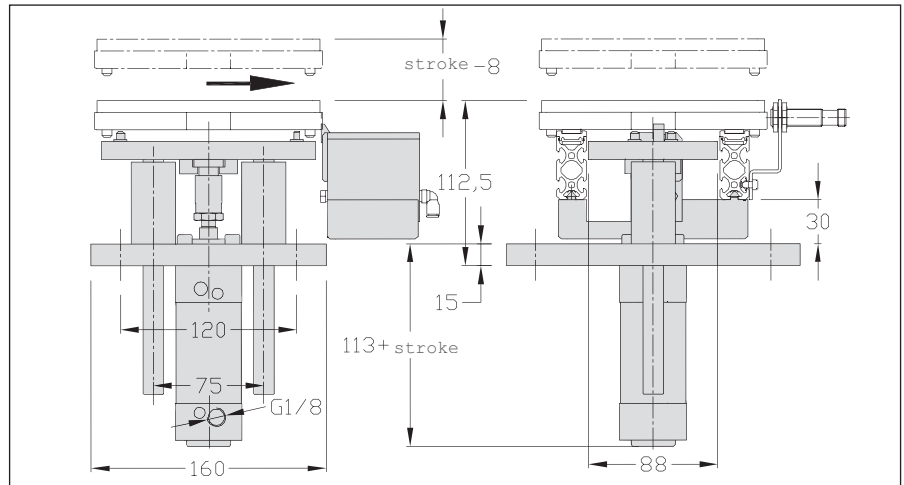

Designation / Dimensions	Order unit	Reference
Lift positioning unit 150 damped pneumatic stopper	1 pce	150.12.000.RAP



## Dead man option, lift positioning units Width 150

### APPLICATIONS

This option is available for all lift positioning units width 150 (references 150.12.000 - 150.12.000.RAP - 150.31.000).

Locking by springs.

Retaining force: 600 N

Useful pressure range: 6 bars.



2 flow rate controllers G1/8 +  
1 connection M5 are required.

Weight: 1.25 kg (stroke 200).

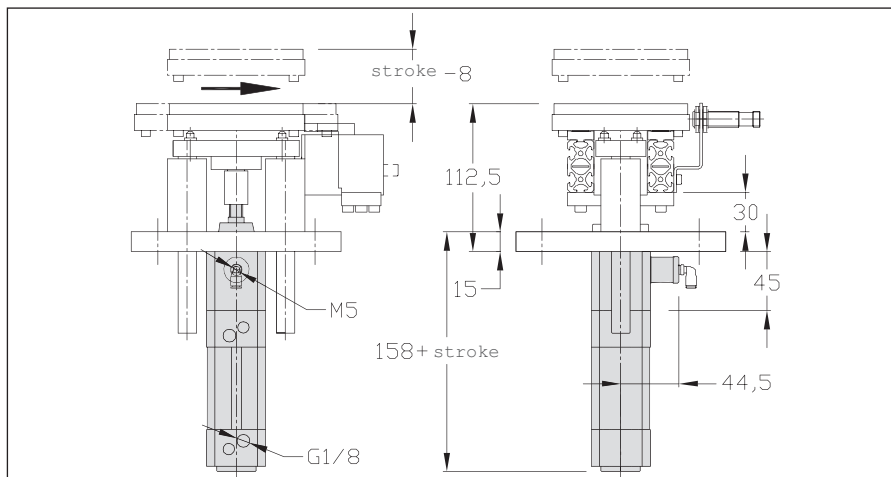

**Designation / Dimensions**

**Dead man option, lift positioning units 150**

**Unit order**

**1 pce**

**Reference**

**110.75.000**

## Sensor bracket M 12x100

### APPLICATIONS

Bracket for workpiece carrier M12x100 sensor.

#### Technical data

- ✘ Stainless steel 2 mm
- ✘ Nut 5 St M4 + screws
- ✘ Detection range: 4 mm

Weight: 0,035 kg

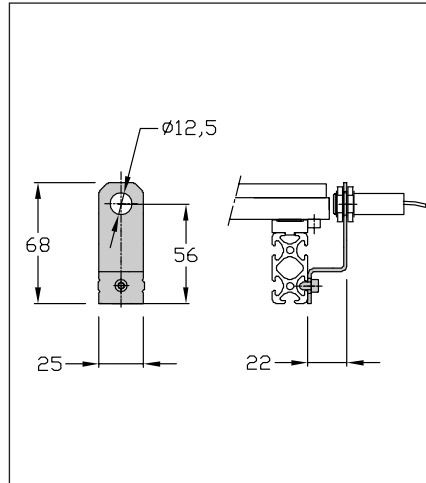

Designation / Dimensions	Order unit	Reference
<b>Sensor bracket 150</b>	<b>1 pce</b>	<b>110.17.000</b>

## Anti bouncing back

### APPLICATIONS

Avoids workpiece carrier bouncing back on stoppers or positioning units in case of high speed. Allows to reduce the changing time of workpiece carriers in the positioning units.

#### Technical data

- ✘ Parts, PA black
- ✘ Fastening parts

Weight: 0,1 kg

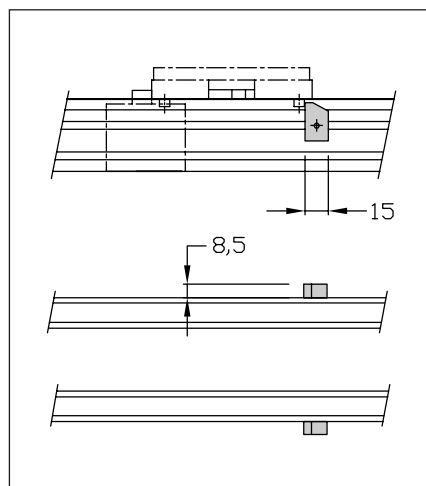

Designation / Dimensions	Order unit	Reference
<b>Anti bouncing back 100</b>	<b>1 set</b>	<b>110.30.000</b>

## Short cams Width 150

### APPLICATIONS

#### Short cams SD-EG SG-ED - Double cams

The short cams and the double cams allow deviation of workpiece carriers from a main line to a secondary line without additional motorization. Economical, compact and very easily managed, they are ideal to set up work stations in derivation



**Do not accumulate the workpiece carriers in the cams.**

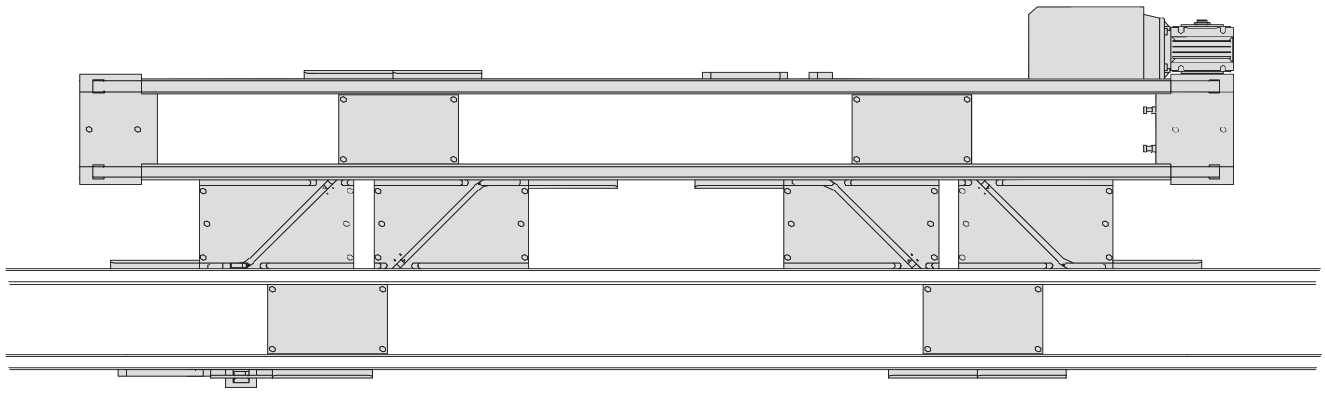

Short cam150

## Double cams Width 150

### APPLICATIONS

The double cams allow deviation of workpieces carriers from a main line to a secondary line without additional motorization.  
Economical, compact and very easily managed, they are ideal to set up work stations in derivation.

## Double cam 24 V Width 150

Two Brushless gear motors controlled by a control box ensure the rotation of the selector.  
A single output for logic controller is necessary.  
Combined with a derivation kit, control and supply can be used on the box of the derivation kit.  
Control module 24 V output: automation, bus module, splitter...  
Standard connectors M12.  
An extension for connection M8 male/female 3 pins between the motor and the control box is required.

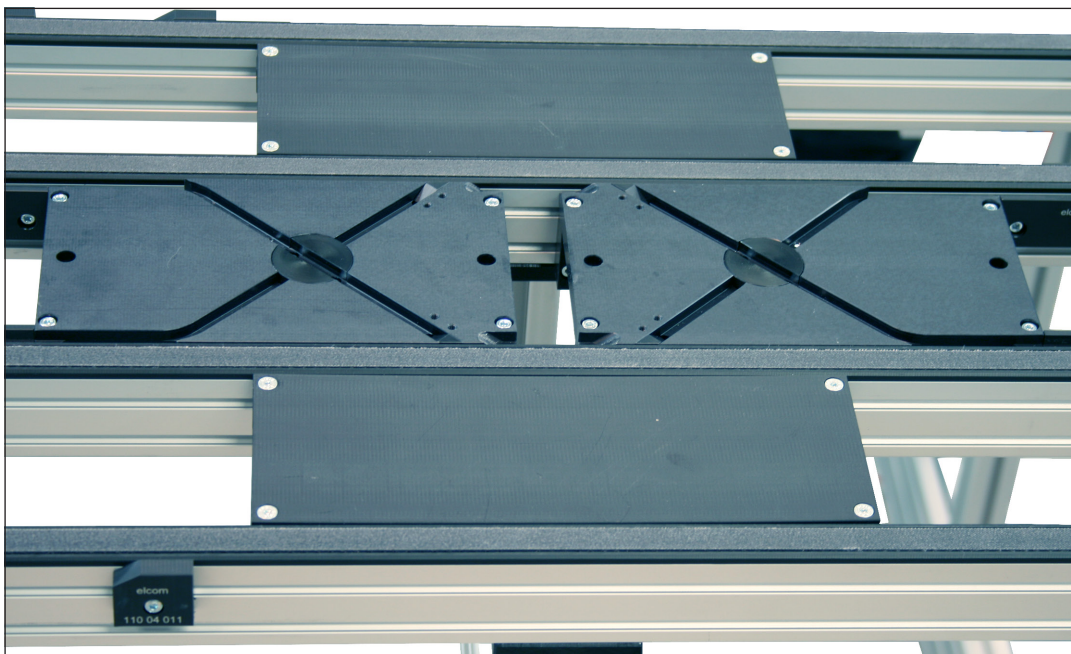

Double cam 150



## Short cams SD-EG/SG-ED Width 150

### Technical data

Complete set including:

- ✘ Cams and guides, PA black
- ✘ Fastening parts
- ✘ Screw and nuts 5 St M4

(1 set SD-EG + 1 set SG-ED are necessary to make a complete derivation)

If a selection is necessary (derivation or not), add the derivation set.

 Maximum load: 2 daN

 Do not accumulate the workpiece carriers in the cams.

Weight: 1,14 kg

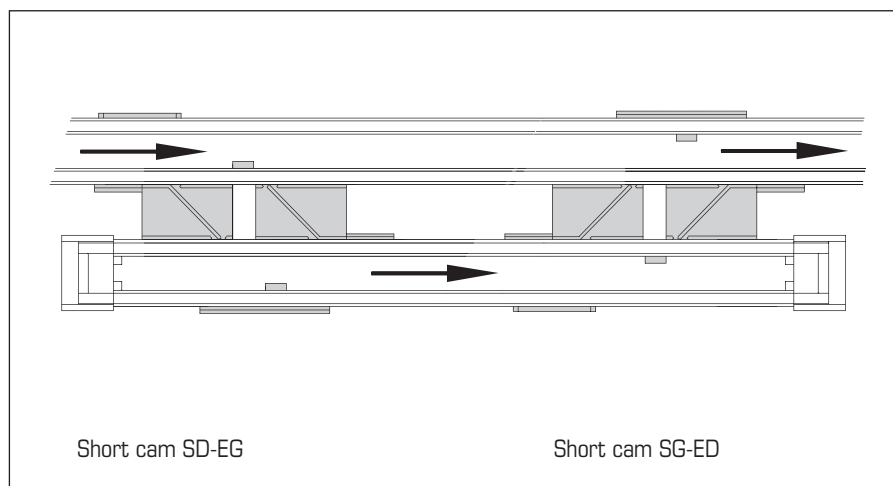
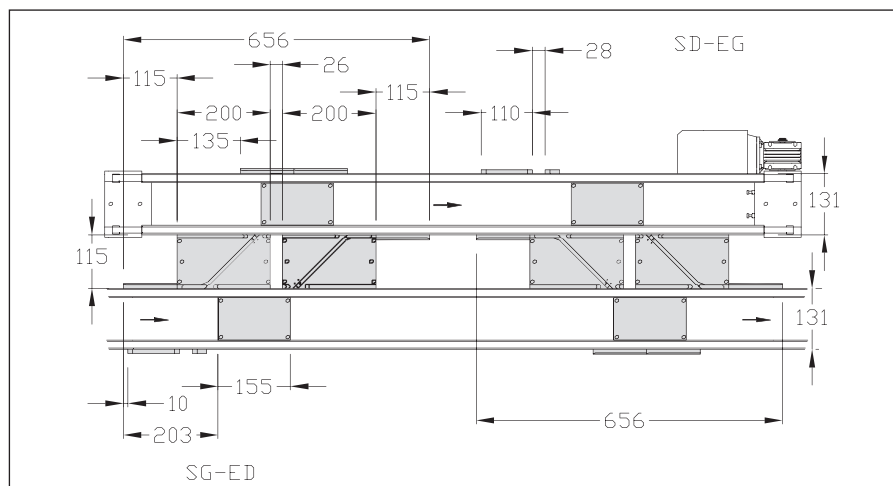

Designation / Dimensions	Order unit	Reference
Short cam 150 SD-EG	1 set	150.46.000
Short cam 150 SG-ED	1 set	150.17.000

## Double cam Width 150

### Technical data

Complete set including:

- ✘ Cam, selectors, ramps and guides, PA black
- ✘ 2 rotative cylinders, (M5)
- ✘ Fastening parts
- ✘ Screw and nuts 5 St M4

If a selection is necessary (derivation or not), add the derivation set.



Maximum load: 2 daN



Do not accumulate the workpiece carriers in the cams.

Weight: 1,72 kg

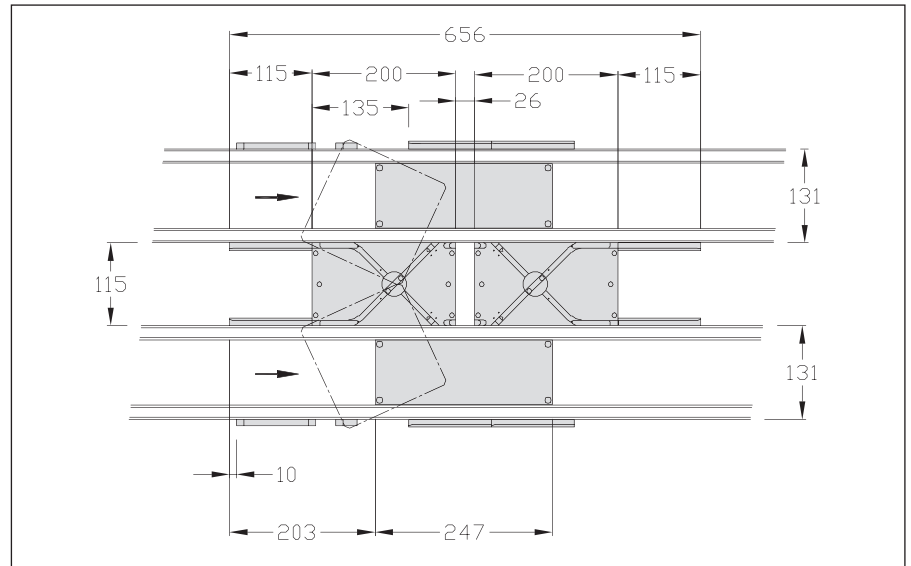

Designation / Dimensions	Order unit	Reference
Double cam150	1 kit	150.21.000





## Positioning kit

### APPLICATIONS

Allows accurate positioning unit on station.

#### Technical data

- x** 2 axis screws M8
- x** 2 hexagonal socket head cap screws M8

Weight: 0,08 kg

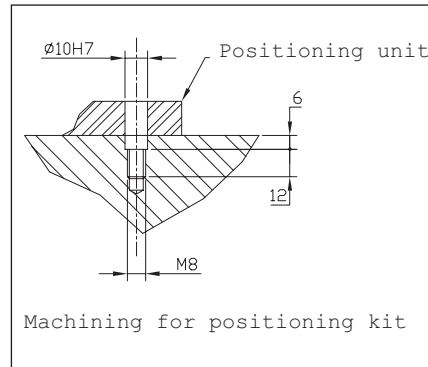

Designation / Dimensions	Order unit	Reference
Positioning kit	1 kit	120.62.000

## Inductive sensor M 12 x 100

### APPLICATIONS

Detection for the workpiece carrier.

#### Technical data

- x** Shielded mounting sensor M12x100
- x** LED control display
- x** PNP-10-30 VDC
- x** Screwed connection
- x** Cable 5 m



Designation / Dimensions	Order unit	Reference
Inductive sensor M 12 x 100	1 set	200.10.200

## Cylinder sensors

### APPLICATIONS

Detection the position of cylinders, stoppers or positioning units.

#### Technical data

- x** 12-27 V-LED control display

Designation / Dimensions	Order unit	Reference
Cylinder sensor, positioning unit	1 set	200.10.201
Cylinder sensor, lift positioning unit	1 set	200.10.202

Conveying unit 24 V  
p 116

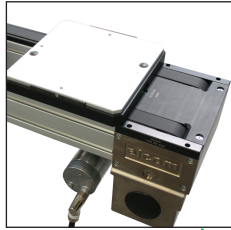

Lift  
p 135

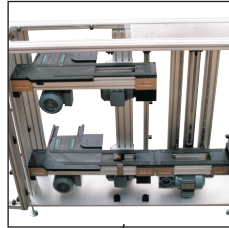

Workpiece carrier  
p 106

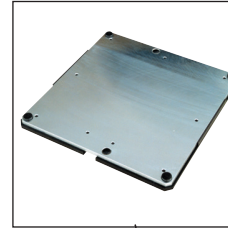

Conveying unit  
p 114

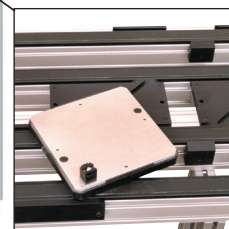
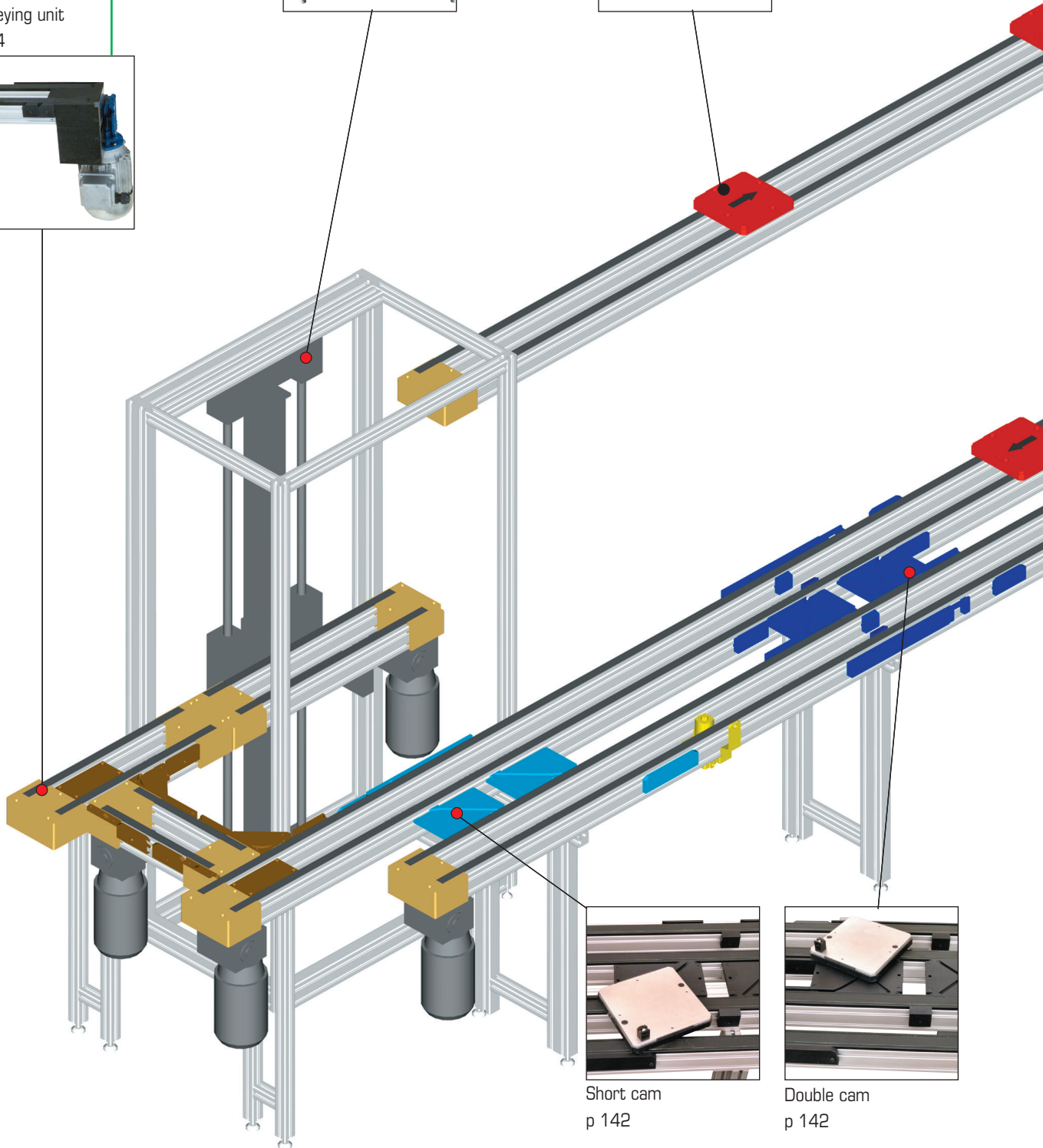
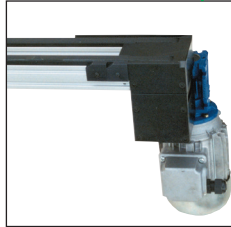

Short cam  
p 142

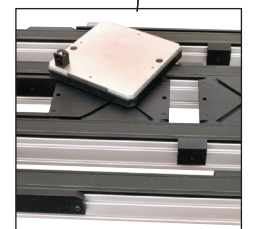

Double cam  
p 142

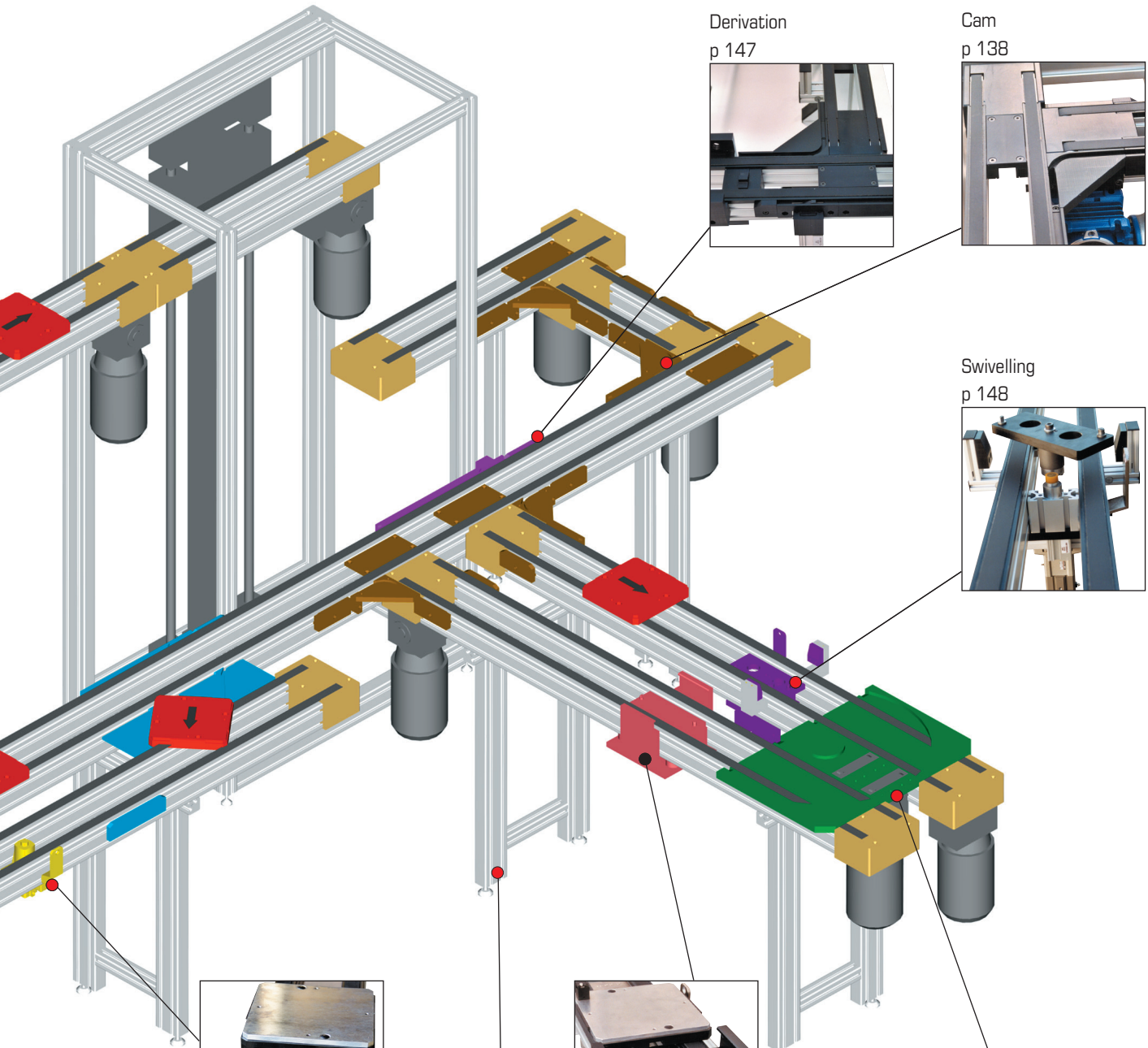

Derivation  
p 147

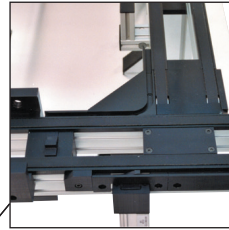

Cam  
p 138

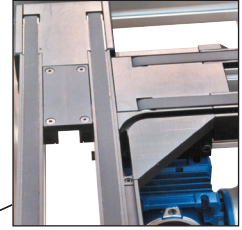

Swivelling  
p 148

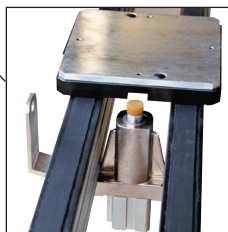
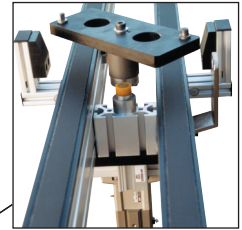

Stopper  
p 152

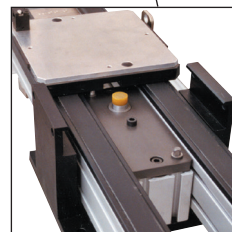

Positioning unit  
p 160

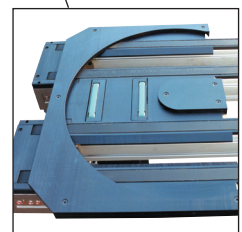

Return 180°  
p 130



Stopper 24 V  
p 155



Conveying unit stand  
p 151

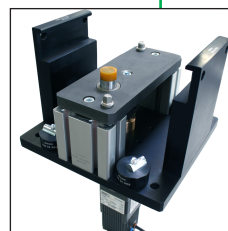

Positioning unit 24 V  
p 163





## Index TLM 2000

Designation	Page	Designation	Page
Data.....	105	Simple stands .....	151
Workpiece carriers .....	106	Double stands .....	151
Workpiece carriers U Width 200.....	109	Stoppers.....	152
Workpiece carriers U shock absorbers (T) Width 200 .....	109	Stoppers Widths 200-300-400 .....	154
Workpiece carriers U, grinded Width 200 .....	110	Stopper 24 V Width 200.....	155
Workpiece carriers U shock absorbers, grinded Width 200 .....	110	Damped stoppers Widths 200 - 300 - 400 .....	156
Workpiece carriers M Width 200 .....	111	Damped stoppers, pneumatic Width 200 .....	157
Workpiece carriers U Widths 300-400 .....	112	Short stoppers Widths 200-300-400 .....	158
Workpiece carriers M Widths 300-400 .....	113	Brush unit.....	159
Conveying units.....	114	Positioning units .....	160
Antistatic set (option) .....	114	Positioning units Widths 200-300-400.....	162
Conveying units Flat belt Widths 200-300-400.....	118	Positioning unit 24 V Automatic stopper Width 200.....	163
Conveying unit Light Timing belt Width 200.....	119	Damped positioning units Widths 200-300-400 .....	164
Conveying unit Heavy Timing belt Width 200 .....	120	Positioning units for station Widths 200-300-400 .....	165
Conveying unit 24 V Width 200.....	121	Damped positioning units for station Widths 200-300-400.....	166
Conveying unit Pushing motor.....	122	Dead man option, positioning units Widths 200-300-400 .....	167
Direct conveying unit Width 200.....	123	Heavy positioning units Widths 200-300-400.....	168
Height reductions Widths 200-300-400 .....	124	Damped heavy positioning units Widths 200-300-400 .....	169
Conveyor cut .....	124	Lift positioning units Widths 200-300-400 .....	170
Cap 200 .....	125	Damped lift positioning unit Widths 200-300-400 .....	171
Cap for motorization light timing belt .....	125	Dead man option, lift positioning units Widths 200-300-400 .....	172
Cap for motorization heavy timing belt.....	125	Bridge positioning units Width 200.....	173
Straight joining for driving unit flat belt.....	126	Press positioning units Widths 200-300-400.....	174
Straight joining for direct driving unit .....	126	Multi-positioning unit Width 200 .....	175
Straight joining for motorization light timing belt .....	127	Reinforcements for positioning unit Widths 300-400 .....	176
Straight joining for motorization heavy timing belt .....	127	Module TLM 2000 Heavy loads Width 200 .....	177
Spacers Widths 200-300-400 .....	128	Logic block .....	178
Half junctions Widths 200-300-400 .....	129	Workpiece carrier sensor .....	179
Returns 180° Widths 200-300.....	131	Sensor brackets M12x100.....	180
Return 180° Width 200 Length 250 .....	132	Positioning kit.....	180
Return 180° Width 400 .....	133	Anti bouncing back.....	181
Chain lubrication set pushing motor .....	134	Inductive sensor M12x100.....	181
Lifts .....	135	Cylinder sensors .....	181
Cams 90° .....	138		
Cams 90°-Widths 200-300-400 .....	139		
Cams 90° timing belt, light motorization Width 200.....	140		
Cams 90° timing belt, heavy motorization Width 200.....	141		
Short cams and double cams .....	142		
Short cams SD-EG, SG-ED Width 200.....	143		
Short cams SD-EG, SG-ED Widths 300-400 .....	144		
Double cam Width 200.....	145		
Double cams Widths 300-400 .....	146		
Derivations Widths 200-300-400.....	147		
Swivellings 90° Widths 200-300-400.....	148		
Swivellings 180° Widths 200-300-400.....	149		
Rotation damper kit .....	150		
Conveying unit stands.....	151		

Download all CAD 3D files



on our website  
[www.elcom-automation.com/transfers](http://www.elcom-automation.com/transfers)

# Data

	<b>TLM 2000</b>			<b>TLM 2000 direct</b>			<b>TLM 2000 timing belt 60 kg</b>			<b>TLM 2000 timing belt 150 kg</b>		
Workpiece carriers (mm)	200x200 200x250 200x300 300x300 300x400 400x400			200x200 200x250 200x300			200x200 200x250 200x300			200x200 200x250 200x300		
Load/workpiece carriers (daN)	10			10			10			10		
Speed (m/min)	9-15-19			9-15-19			9-15-19			14		
Length of conveying unit Mini Maxi	500 6250			500 6250			500 6160			500 6250		
Maxi accumulation load per motor (daN)	100			60			60			150		
Motor power (380 V three-phase)	Speed m/min	KW	A	Speed m/min	KW	A	Speed m/min	KW	A	Speed m/min	KW	A
	9	0,25	0,7	9	0,25	0,7	9	0,25	0,7	14	0,55	1,6
	15	0,37	1,2	15	0,37	1,2	15	0,37	1,2			
	19	0,55	1,4	19	0,55	1,4	19	0,55	1,4			

The maximum lengths of the conveying units are respectively:

\* 6250 mm for TLM 2000

\* 6160 mm for TLM 2000 timing belt light motorization

For long spans, several elements can be joined end to end.

For important accumulations, the length of the conveying units is adapted to the load.

It is recommended to place sensors in order to control accumulation of the load.

Pneumatic cylinders must be equipped with flow rate controllers.

It is possible for long spans to be cut in order to facilitate the dismantling of the machines.

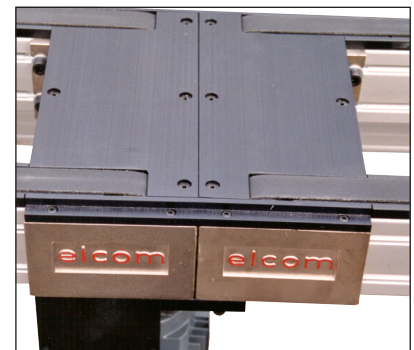

## TLM 2000 Width 200

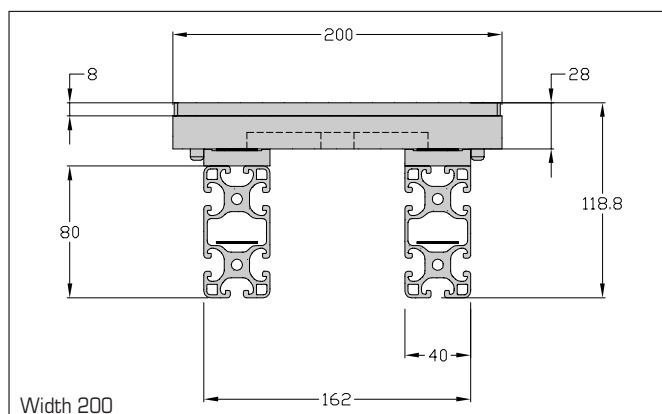

## TLM 2000 Widths 300 and 400

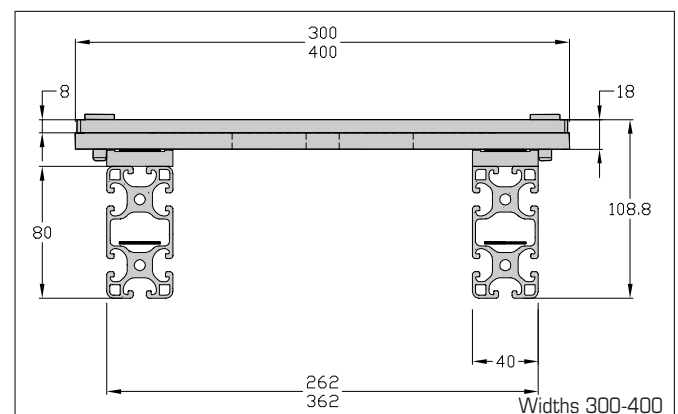

TLM 2000



## Workpiece carriers

The workpiece carriers allow the mounting of holders which ensure an accurate positioning of the assembly during the process.

The workpiece carriers consists of two plates.

The upper aluminium plate allows the fastening of workpieces, ensures the geometrical behaviour of workpiece carrier as well as the positioning accuracy. Machining (drillings and tappings) can be made according to the customer's wish.

Stainless steel bushes located in the aluminium plate guarantee

resistance to wear and a perfect accuracy. The PA base has an extremely low friction coefficient and lays on the conveying belts. This base hosts 4 guiding pins (specific to **elcom**) and has the necessary shape to ensure stoppers proper functioning.

Metalic bars are located on each side of the workpiece carrier in order to detect them at several workstations. The characteristics of stoppers, guiding pins with springs can be found in the next pages.

### Variable length of **elcom's** workpiece carriers and specific workpiece carriers

Standard workpiece carriers are available to install the workpieces that will be conveyed. In many cases, the surface area workpiece carrier is not sufficient. Specific workpiece carriers can be supplied. The use of 4 guiding pins makes it possible to vary the length of workpiece carrier

and to optimize cycle times. The guiding pins remain in the position of the nearest standard workpiece carrier. So, all the standard elements such as cams are usable without modification. The following variants for a TLM 2000 system clearly show the possibilities:

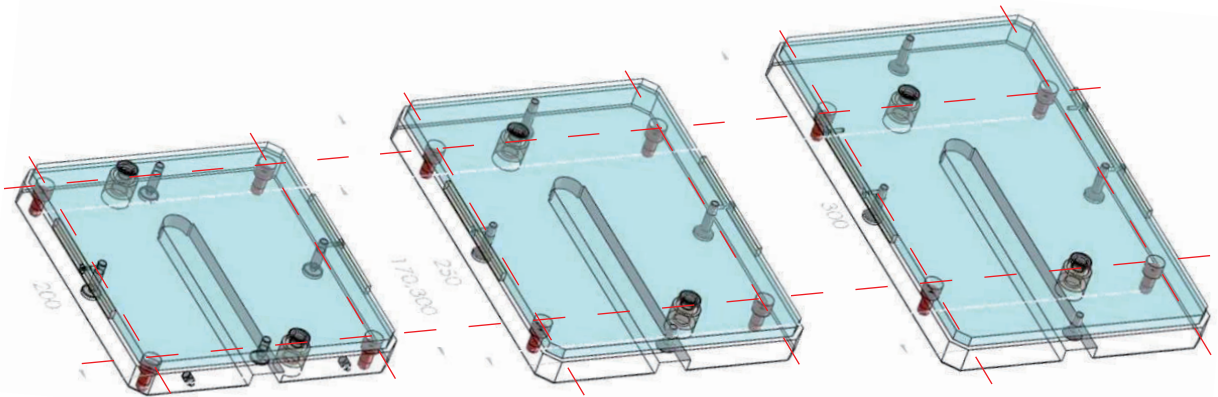

Standard square dimensions:

200 x 200 mm  
300 x 300 mm  
400 x 400 mm

Standards rectangle dimensions:

200 x 250 mm  
200 x 300 mm  
300 x 400 mm

Customized customer's dimensions:

200 x XXX mm  
300 x XXX mm  
400 x XXX mm  
XXX = Dimension defined by the user

The lay-out of guide pins is identical in width. However, in the length direction, the guide pins of a 400x400 workpiece carrier have a larger gap than the 200x200 workpiece carriers. In case of use of workpiece

carriers of several dimensions on the same transfer unit, lay-out of the guiding pins must be alike.

## Workpiece carriers

### Workpiece carriers and specific adjustments

Standard workpiece carriers are available to install the customers' workpiece. In many cases, the surface area of workpiece carrier is not sufficient. Specific workpiece carriers must be provided. These must be mostly defined by our customer and be applied to our standard workpiece carriers.

Our standard workpiece carriers and the specific adjustments form together the basis of a secure workpiece conveying. Furthermore this

allows an optimum supply of the workpiece carriers at the workbenches. Depending on use, the workpiece carrier will be positioned with an accuracy of 30 µm.

In addition to the positioning, pressure forces are discharged by the workpiece carriers. Our standard modules offer here a derivation of the force up to 40 kN (4 tons).

## Workpiece carriers U and M

Workpiece carriers are used to support and position the components during the process.

The upper plate (made of aluminium) is used to fix the components and perform an accurate positioning of the workpiece carrier.

The PA base (which has a very low friction coefficient) is used to shelter the pins and to stop the workpiece carrier on the stopper.

Steel bushes assure perfect accuracy and resistance against deterioration.

On each side of workpiece carrier, small metallic bars allow detection of workpiece carriers at different positions.

### Unidirectional workpiece carriers

They are perfectly compatible with a 180° swivelling.

Possibility of adding shock absorbers to limit the shock between the workpiece carriers and to reduce the noise (T).

### Multidirectional workpiece carriers

For square workpiece carriers only.

They are perfectly compatible with 90°, 180° and 270° swivellings, delivered with 2 bushes and 2 additional detection bars.



Workpiece carrier U

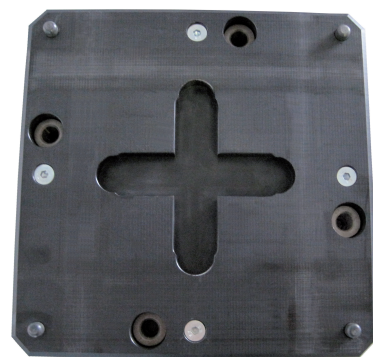

Workpiece carrier M

## Workpiece carriers with shock absorber T

The aluminum plate is provided with two drills on the side in the direction of motion. Shock absorbers are inserted in these drills. These damp the impact against the plate and therefore reduce noise pollution.

The workpiece carrier with shock absorber T corresponds to the standard U-type workpiece carrier.



**The use of the workpiece carrier with shock absorbers require the installation of a stopper before each positioning unit. This avoids the shearing of shock absorbers.**



## Grinded workpiece carriers (G)

The upper aluminium plate of the grinded workpiece carrier ensures a great dimensional stability and a positioning accuracy. It has a higher flatness than a standard workpiece carrier. These workpiece carriers are recommended if large drills or millings in the aluminium plate are planned. Their structure correspond to the standard workpiece carriers.

## Workpiece carriers U Width 200

### Technical data

- ✗ Plate Al
- ✗ Base, PA black
- ✗ 2 steel bushes
- ✗ 4 pins PA
- ✗ 4 springs
- ✗ 3 countersunk screws M6x25
- ✗ 1 countersunk screw M6x16
- ✗ 2 detection bars
- ✗ 2 plugs

B = 200 C = 170

B = 250 C = 170

B = 300 C = 170

 Maximum load: 10 daN

Weight: 200x200: 1,75 kg  
200x250: 2,20 kg  
200x300: 2,63 kg

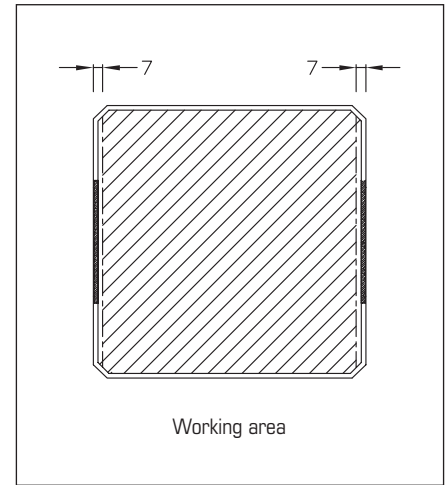
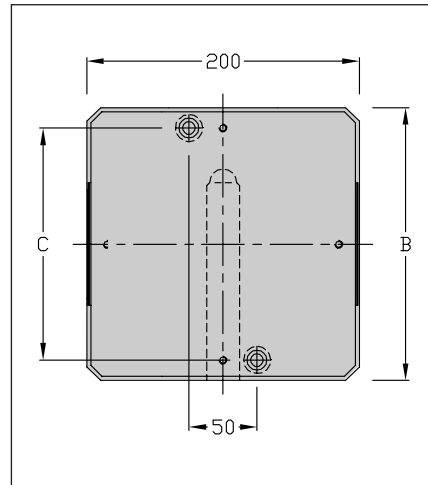
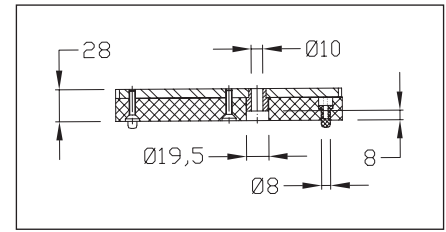
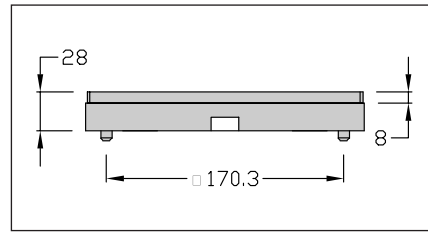

Designation / Dimensions	Order unit	Reference
Workpiece carrier U 200x200	1 pce	120.61.000
Workpiece carrier U 200x250	1 pce	125.62.000
Workpiece carrier U 200x300	1 pce	123.62.000

## Workpiece carriers U shock absorbers (T) Width 200

### APPLICATIONS

The use of workpiece carriers with shock absorbers (workpiece carriers T) limits the shock between the workpiece carriers and reduces the noise.

For unidirectional workpiece carriers only.  
Set up a stopper before each positioning unit.

Weight: 200x200: 1,75 kg  
200x250: 2,20 kg  
200x300: 2,63 kg

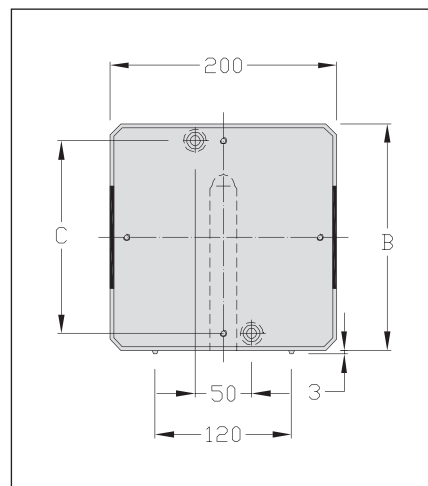

Designation / Dimensions	Order unit	Reference
Workpiece carrier U 200x200 T	1 pce	120.61.000.T
Workpiece carrier U 200x250 T	1 pce	125.62.000.T
Workpiece carrier U 200x300 T	1 pce	123.62.000.T

## Workpiece carriers U, grinded Width 200

### Technical data

- ✗ Grinded plate Al
- ✗ Base, PA black
- ✗ 2 steel bushes
- ✗ 4 pins PA
- ✗ 4 springs
- ✗ 3 countersunk screws Fhc M6x25
- ✗ 1 countersunk screw Fhc M6x16
- ✗ 2 detection bars
- ✗ 2 plugs

B = 200 C = 170

B = 250 C = 170

B = 300 C = 170

 Maximum load: 10 daN

Weight: 200x200: 1,75 kg  
 200x250: 2,20 kg  
 200x300: 2,63 kg

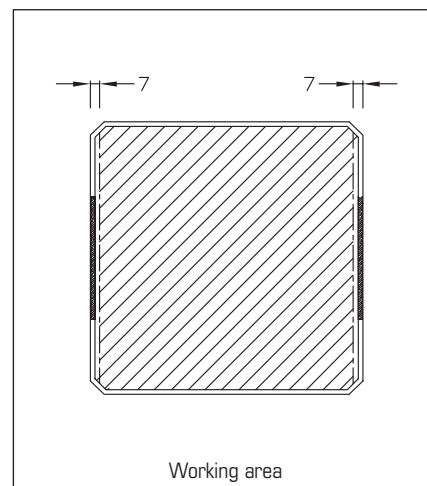
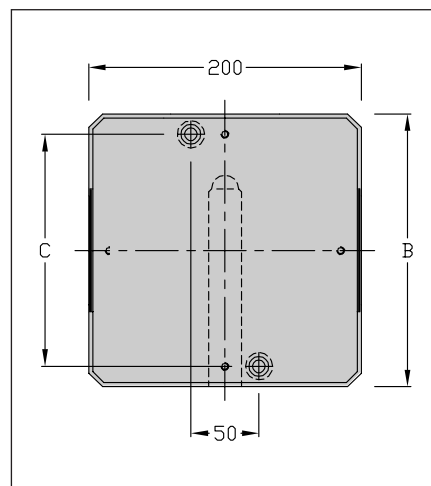
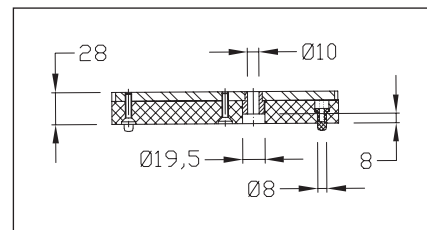
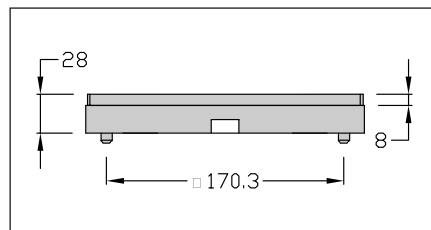

Designation / Dimensions	Order unit	Reference
Workpiece carrier U 200x200 grinded	1 pce	120.61.000.G
Workpiece carrier U 200x250 grinded	1 pce	125.62.000.G
Workpiece carrier U 200x300 grinded	1 pce	123.62.000.G

## Workpiece carriers U shock absorbers, grinded Width 200

### APPLICATIONS

The use of workpiece carriers with shock absorbers (workpiece carriers T) limits the shock between the workpiece carriers and reduces the noise.

For unidirectional workpiece carriers only.

Set up a stopper before each positioning unit.

Weight: 200x200: 1,75 kg  
 200x250: 2,20 kg  
 200x300: 2,63 kg

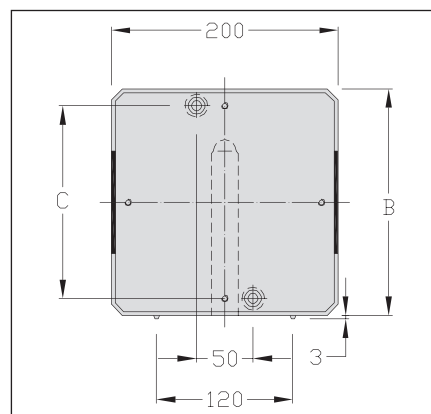

Designation / Dimensions	Order unit	Reference
Workpiece carrier U 200x200 T grinded	1 pce	120.61.000.TG
Workpiece carrier U 200x250 T grinded	1 pce	125.62.000.TG
Workpiece carrier U 200x300 T grinded	1 pce	123.62.000.TG

## Workpiece carriers M Width 200

### Technical data

- ✗ Plate Al (grinded with option G)
- ✗ Base, PA black
- ✗ 2 steel bushes
- ✗ 4 pins PA
- ✗ 4 springs
- ✗ 4 countersunk screws M6x25
- ✗ 2 detection bars
- ✗ 2 plugs

B = 200 C = 170

B = 250 C = 170

B = 300 C = 170



Maximum load: 10 daN

Weight: 200x200: 1,75 kg  
200x250: 2,20 kg  
200x300: 2,63 kg

### Option: set 90°

- ✗ 2 detection bars
- ✗ 2 steel bushes
- ✗ 2 plugs

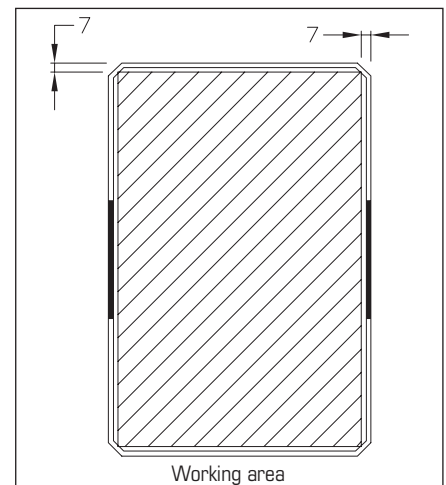
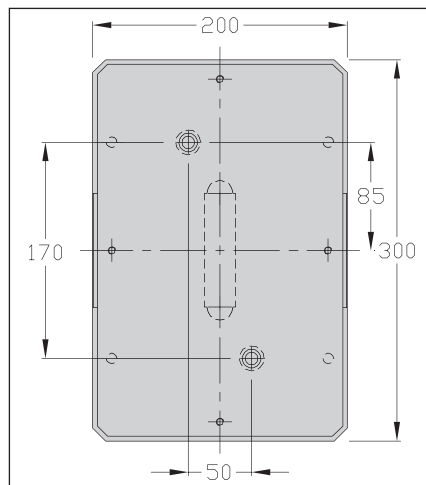
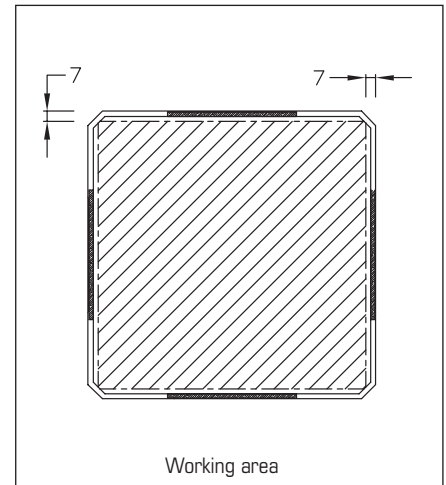
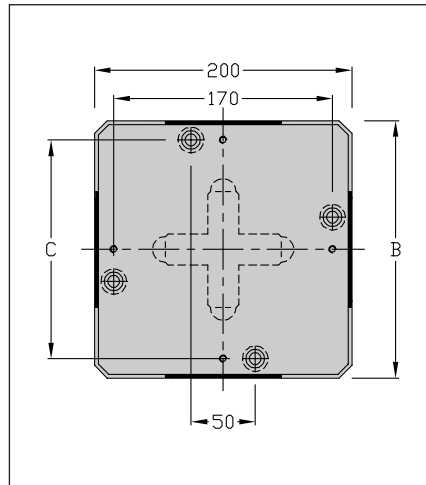
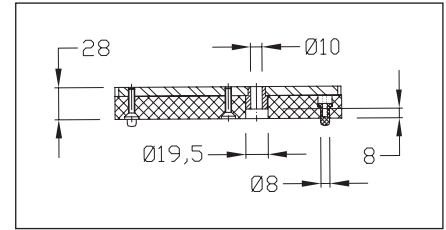
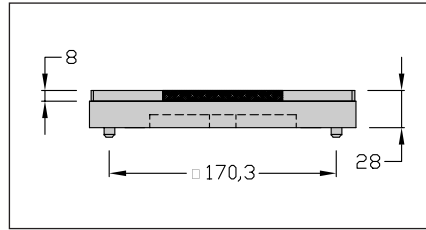

TLM 2000

Designation / Dimensions	Order unit	Reference
Workpiece carrier M 200x200	1 pce	120.63.000
Workpiece carrier M 200x250	1 pce	125.73.000
Workpiece carrier M 200x300	1 pce	123.73.000
Set 90° 200x200	1 pce	900.00.001
Workpiece carrier M 200x200 grinded	1 pce	120.63.000.G
Workpiece carrier M 200x250 grinded	1 pce	125.73.000.G
Workpiece carrier M 200x300 grinded	1 pce	123.73.000.G



## Workpiece carriers U Widths 300-400

### Technical data

- ✗ Plate Al
- ✗ Base, PA black
- ✗ 2 steel bushes
- ✗ 4 pins PA
- ✗ 4 springs
- ✗ 9 countersunk screws M6x16
- ✗ 2 detection bars
- ✗ 2 plugs

A = 300 B = 300 C = 270

A = 300 B = 400 C = 370

A = 400 B = 400 C = 370



Maximum load: 10 daN

Weight: 300x300: 3,10 kg

300x400: 4,10 kg

400x400: 5,40 kg

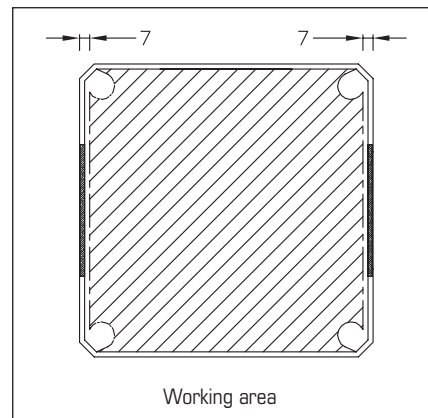
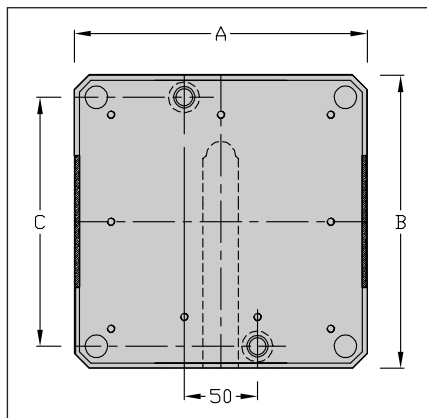
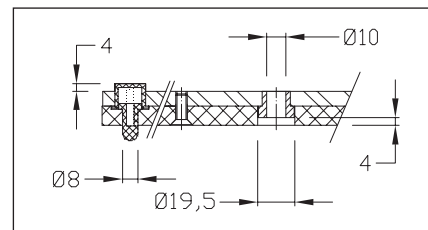
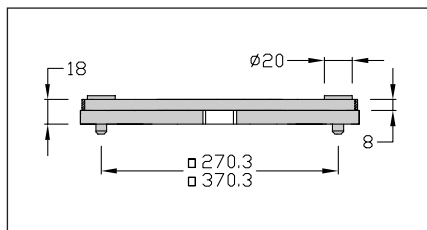

Designation / Dimensions	Order unit	Reference
Workpiece carrier U 300x300	1 pce	130.61.000
Workpiece carrier U 300x400	1 pce	134.62.000
Workpiece carrier U 400x400	1 pce	140.61.000

## Workpiece carriers U shock absorbers (T) 300-400

### APPLICATIONS

The use of workpiece carriers with shock absorbers (workpiece carriers T) limits the shock between the workpiece carriers and reduces the noise.

For unidirectional workpiece carriers only.

Set up a stopper before each positioning unit.

A = 300 D = 220 A = 400 D = 320

Weight: 300x300: 3,10 kg

300x400: 4,10 kg

400x400: 5,40 kg

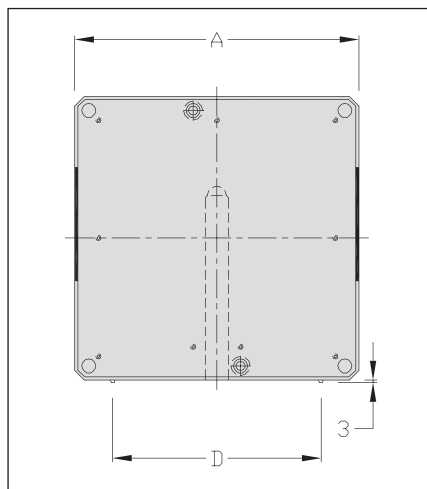

Designation / Dimensions	Order unit	Reference
Workpiece carrier U 300x300 T	1 pce	130.61.000.T
Workpiece carrier U 300x400 T	1 pce	134.62.000.T
Workpiece carrier U 400x400 T	1 pce	140.61.000.T

## Workpiece carriers M Widths 300-400

### Technical data

- ✘ Plate Al
- ✘ Base, PA black
- ✘ 2 steel bushes
- ✘ 4 pins PA
- ✘ 4 springs
- ✘ 8 countersunk screws M6x16
- ✘ 2 detection bars
- ✘ 2 plugs

A = 300 B = 300 C = 270 D = 270  
 A = 300 B = 400 C = 270 D = 270  
 A = 400 B = 400 C = 370 D = 370

 Maximum load: 10 daN

Weight: 300x300: 3,10 kg  
 300x400: 4,10 kg  
 400x400: 5,40 kg

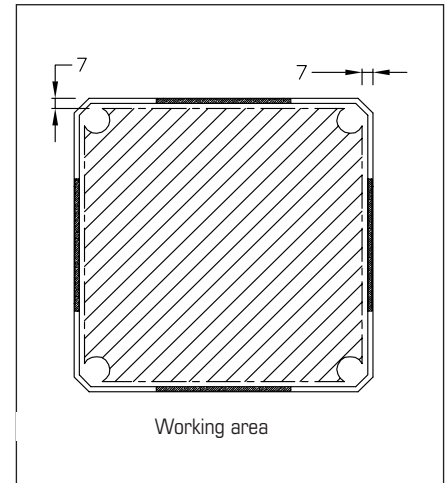
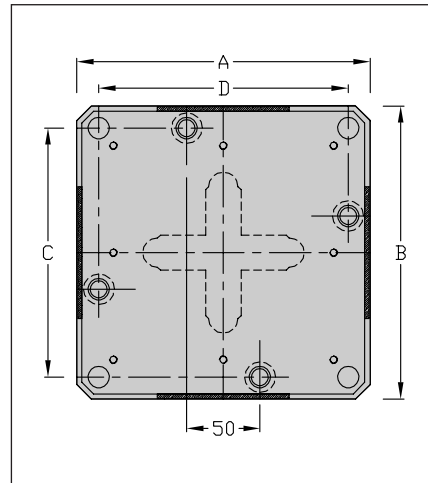
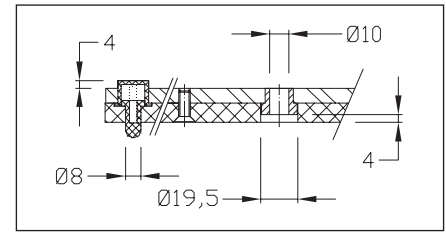
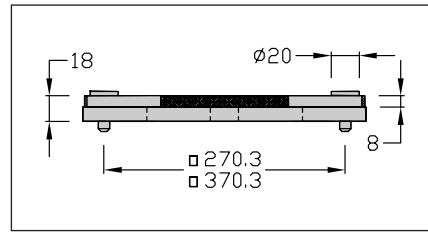

### Option: set 90°

- ✘ 2 detection bars
- ✘ 2 steel bushes
- ✘ 2 plugs

Designation / Dimensions	Order unit	Reference
Workpiece carrier M 300x300	1 pce	130.63.000
Workpiece carrier M 300x400	1 pce	134.73.000
Workpiece carrier M 400x400	1 pce	140.63.000
Set 90° 300 and 400	1 pce	900.00.003

## Conveying units Flat belt

Moving and accumulating of workpiece carriers.

The motor can be fitted either vertically or horizontally, on the right or left side.

According to the load, longer spans can be joined end to end by a straight joining.

The cutting of the conveyors allows division of the length, making transport and installation of the lines easier.

They also allow to make important lengths for reduced loads.

Provide a spacer every meter.

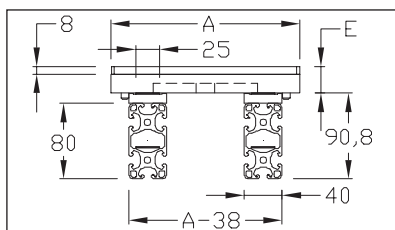

## Direct conveying units

Moving and accumulating of workpiece carriers.

The motor can be fitted either vertically or horizontally, on the right or left side.

Perfectly compatible with the other conveying units.

The use of a new antistatic timing belt enables «Flex-proof» weldings.

Timing belts' change is highly reduced.

Provide a spacer every meter.

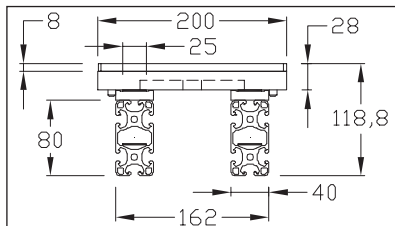

## Antistatic set (option)

The antistatic set will divert through metal rollers the frame's static charge caused by the belt's friction.

The charge will be dissipated by the frame's grounding.

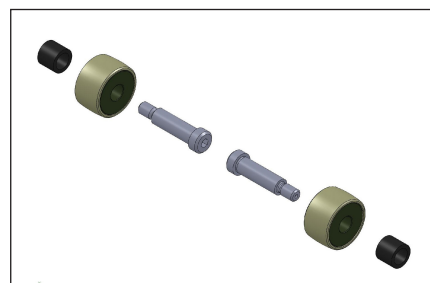

## Conveying units light timing belt

Moving and accumulating of workpiece carriers.

The motor can be fitted either vertically or horizontally, on the right or left side.

Perfectly compatible with the other conveying units.

The use of antistatic timing belts width 25 mm facilitates the maintenance when changing belts.

Belt guides are pressed into aluminium profile housings.

Provide a spacer every meter and every extremity.

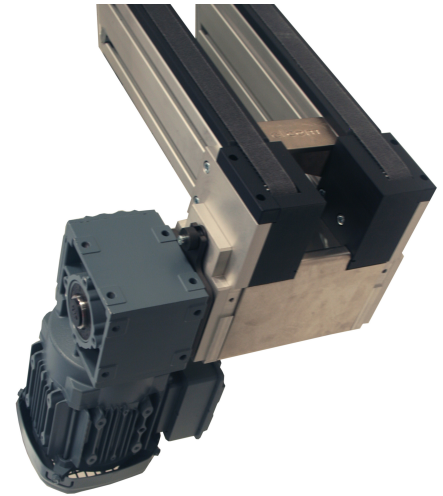
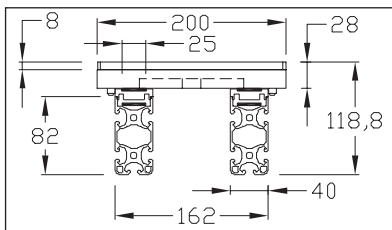

## Conveying units heavy timing belt

Moving and accumulating of workpiece carriers.

The motor can be fitted either vertically or horizontally, on the right or left side.

Perfectly compatible with the other conveying units.

The use of antistatic timing belts width 32 mm enables to convey important loads and facilitates maintenance when changing belts.

Belt guides are pressed into aluminium profile housings.

Provide a spacer every meter and every extremity.

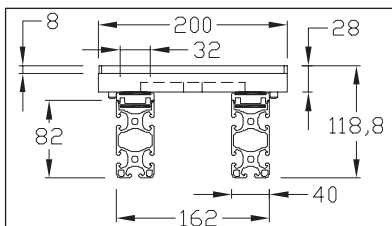

## Conveying unit 24 V Width 200

### APPLICATION

Moving and accumulating of workpiece carriers width 200 mm.

According to the load, longer spans can be joined end to end by straight joinings.

The cuttings of conveyors allow division of the lengths, making transport and installation lines easier.

The Flexproof type welding belt greatly reduces the change of belts.

Spacers have to be fitted between the profiles every meter to ensure a perfect parallelism of the two profiles.

This conveying unit is supplied with a Brushless motor factory-programmed according to

your speed and acceleration ramp requirements. The use of a Brushless gear motor facilitates the wiring.



**elcom ITS 24 V**



## Conveying unit Pushing motor

### APPLICATIONS

Moving and accumulating of workpiece carriers 200x200 and 400x400 on a flat belt unit with pushing motor.

The motor can be fitted either vertically or horizontally, on the right or left side.

According to the load, longer spans can be joined end to end by straight joinings.

The cuttings of conveyors allow division of the lengths, making transport and installation of the lines easier.

Spacers have to be fitted between the profiles every 1 meter to ensure a perfect parallelism of the profiles.

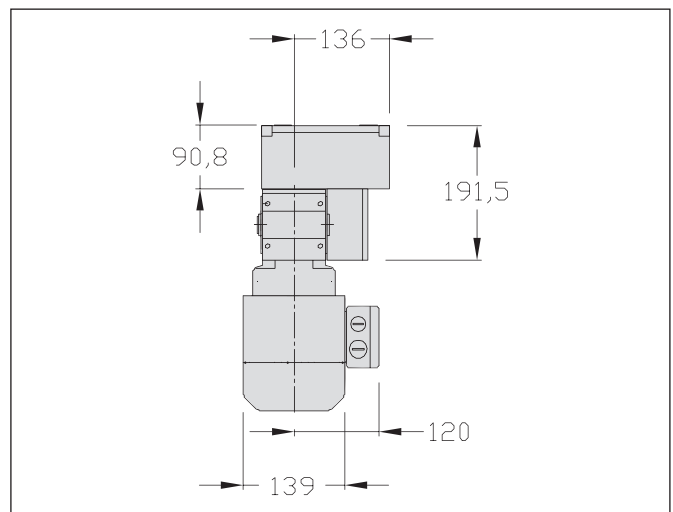
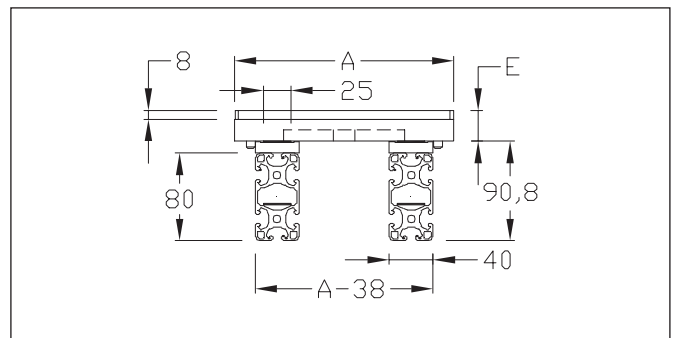



## Conveying units Flat belt Widths 200-300-400

### Technical data

Length mini L = 500 mm  
 Length maxi L = 6 250 mm

For longer spans and according to the load, use several conveying units.

### Conveying unit including

- ✗ 1 idling unit
- ✗ 1 driving unit  
 speed: 9, 15 or 19 m/min  
 (other speed on request)
- ✗ Motor: 230/400 V three-phase  
 0,25 KW (9 m/min) I: 0,7 A  
 0,37 KW (15 m/min) I: 1,2 A  
 0,55 KW (19 m/min) I: 1,4 A

### Conveyor length

- ✗ 2 profiles 8 80x40, al anodized
- ✗ 2 belt guides, PA black
- ✗ 2 belts width 25 mm  
 thickness 1,6 mm, welded



Maximum load /6 m: 200 daN  
 Maximum accumulation load /6 m:  
 100 daN

### Belt length in mm

$L_{\text{welded}} = [(L-100) \times 2 + 173] \times 0,98$

Weight: 200: 15,7 kg +/-m: 6,7 kg  
 300: 18,5 kg +/-m: 6,7 kg  
 400: 21,1 kg +/-m: 6,7 kg

### Antistatic option:

To be ordered with the initial assembling:

- 2 shouldered screws
- 2 steel rollers

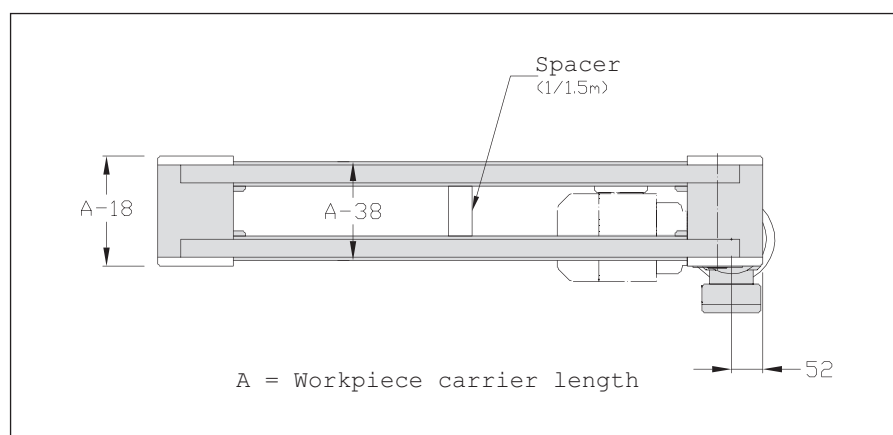
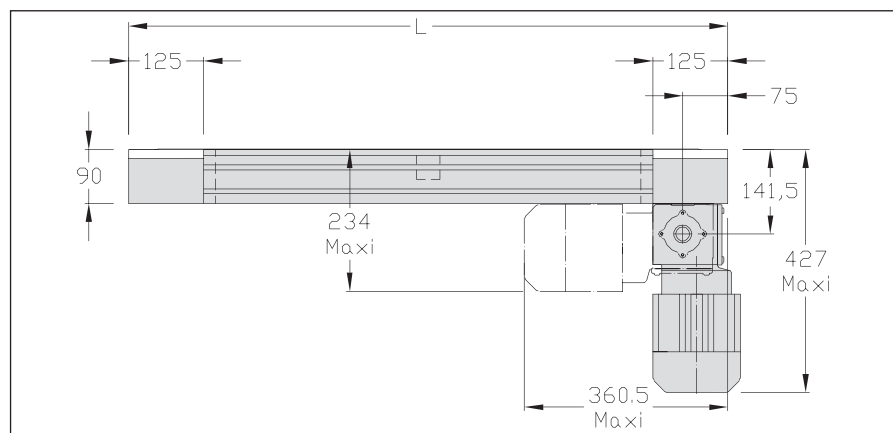
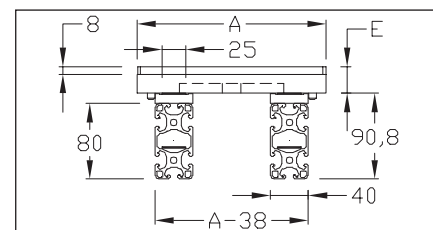
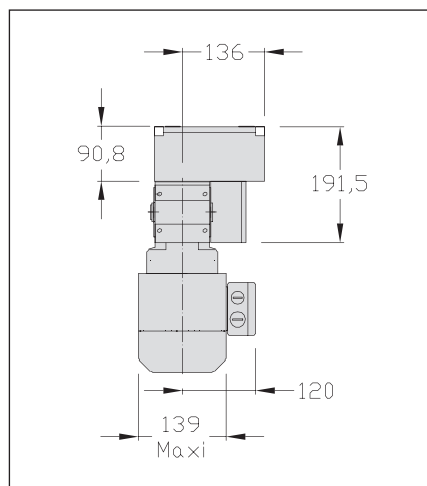

Designation / Dimensions	Order unit	Reference
Conveying unit 200 Flat belt	1 pce	120.02.000.**
Conveying unit 300 Flat belt	1 pce	130.02.000.**
Conveying unit 400 Flat belt	1 pce	140.02.000.**
Conveying length	m	120.02.000.A
Antistatic set	1 pce	120.02.000.C

(\*\* = speed of motor m/min: 9, 15 or 19 eg: 120.02.000.09)

# Conveying unit Light Timing belt Width 200

## Technical data

Length mini L = 500 mm

Length maxi L = 6 160 mm

For longer spans and according to the load, use several conveying units.

## Conveying unit

✘ 1 idling unit

✘ 1 driving unit

speed: 9, 15 or 19 m/min

✘ 1 motor 240/400 V three-phase

0,25 KW (9 m/min) I: 0,7 A

0,37 KW (15m/min) I: 1,2 A

0,55 KW (19m/min) I: 1,4 A

## Conveyor length

✘ 2 profiles 8 82x40, al anodized

✘ 2 belt guides, PA black

✘ 2 antistatic belts

width 25 mm, 5 mm step



Maximum load /6 m: 120 daN

Maximum accumulation load /6 m:

60 daN

Weight: 16,7 kg + 6,8 kg/m

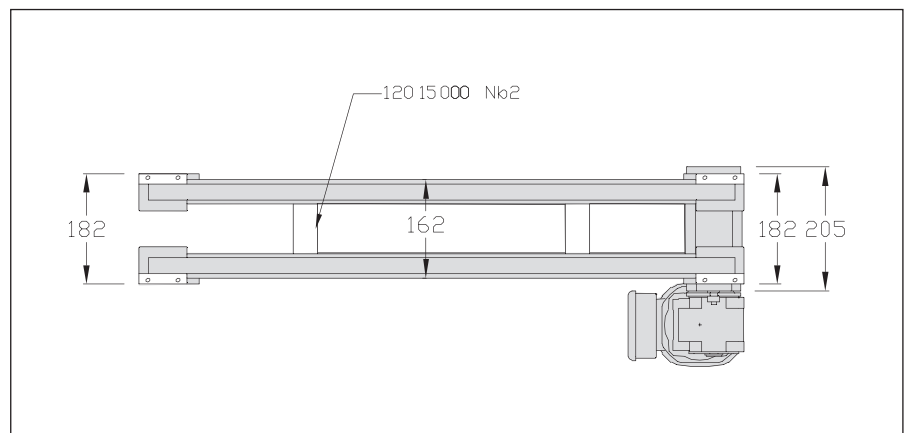
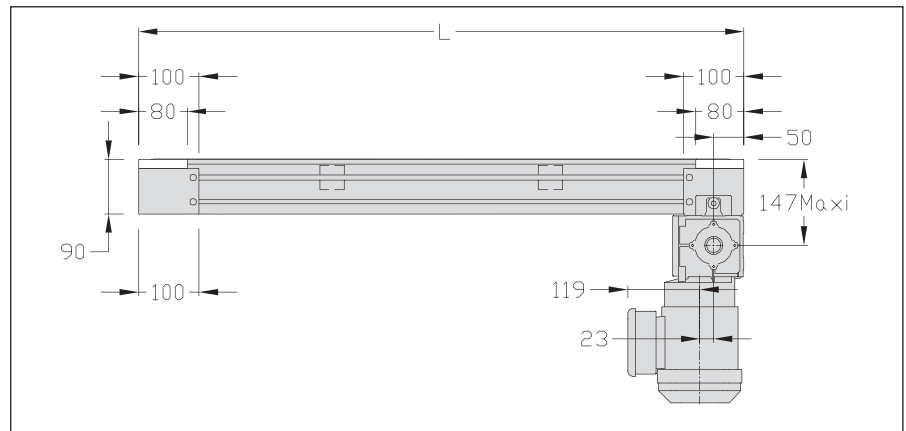
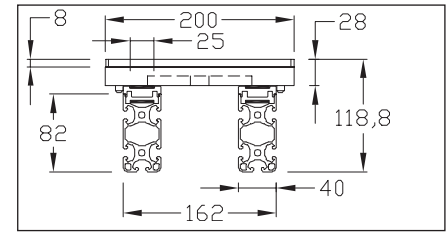
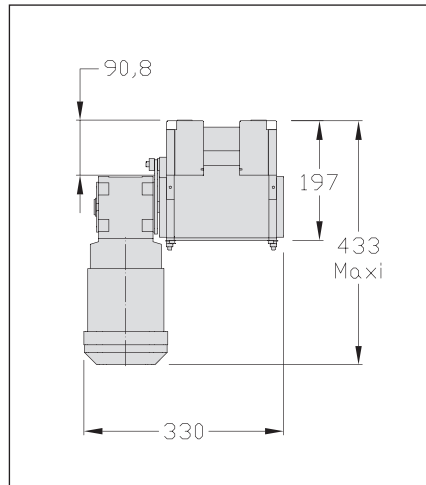

Designation / Dimensions	Order unit	Reference
Conveying unit 200 Light Timing belt	1 pce	120.87.000.**
Conveying length	m	120.87.000.A

(\*\* = speed of motor m/min: 9, 15 or 19 eg: 120.87.000.09)

## Conveying unit Heavy Timing belt Width 200

### Technical data

Length mini L = 500 mm  
 Length maxi L = 6 250 mm

For longer spans and according to the load, use several conveying units.

### Conveying unit

- ✘ 1 idling unit
- ✘ 1 driving unit  
 speed: 14 m/min
- ✘ 1 motor 240/400 V three-phase  
 0,55 KW (14m/min) I: 1,6 A

### Conveyor length

- ✘ 2 profiles 8 82x40, al anodized
- ✘ 2 belt guides, PA black
- ✘ 2 antistatic belts  
 width 32 mm, 5 mm step

- ⚠ Maximum load /6 m: 300 daN  
 Maximum accumulation load /6 m:  
 150 daN

Weight: 21,2 kg + 6,9 kg/m

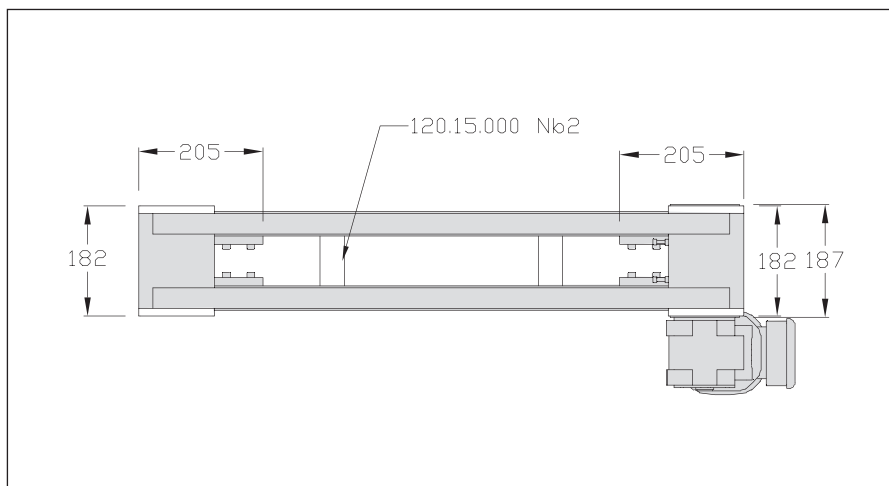
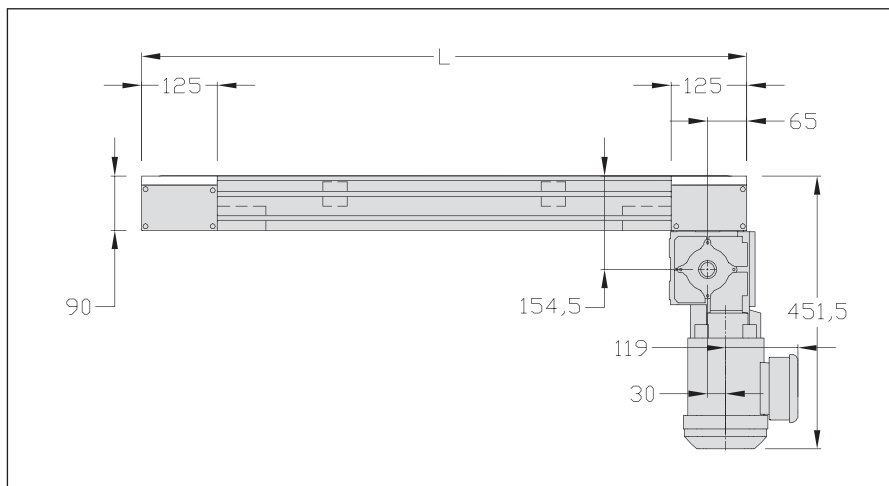
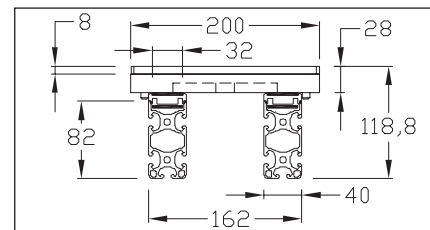
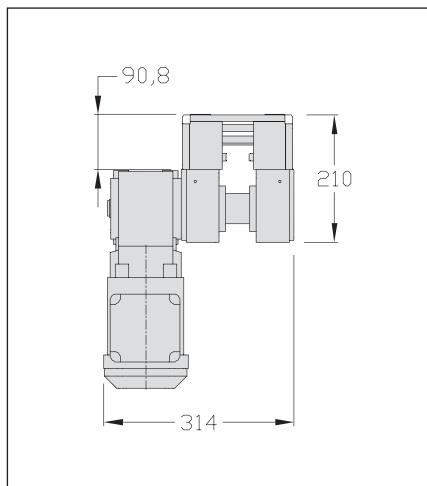

Designation / Dimensions	Order unit	Reference
Conveying unit 200 Heavy timing belt	1 pce	120.80.000.14
Conveying length	m	120.80.000.A

## Conveying unit 24 V Width 200

### Technical data

Length mini L= 500 mm

Length maxi L= 6 250 mm

For longer spans and according to the load,  
use several conveying units.

### Conveying unit including

- ✘ 1 idling unit
- ✘ 1 driving unit
  - Speed: 9 to 19 m/min,  
factory-programmed.
  - Possible stop in case of accumulation
- ✘ 1 gear motor 24 V
  - 0,15 KW
  - I: minimum supply voltage 10 A

### Conveyor length

- ✘ 2 profiles 8 80x40, al anodized
- ✘ 2 belt guides, PA black
- ✘ 2 timing belts width 25 mm,  
thickness 1,8 mm

Maximum load / 6 m: 120 daN

Maximum accumulation load / 6 m: 60 daN

### Belt length (in mm):

$$L_c = [(L-250) \times 2 + 733] \times 0.98$$

Power supply: 24 VDC

Supply current: 8.5 A

Control voltage: 24 VDC

Control current: 10 mA

2 control outputs, 2 status inputs.

Weight: 11 kg + 6.7 kg /m

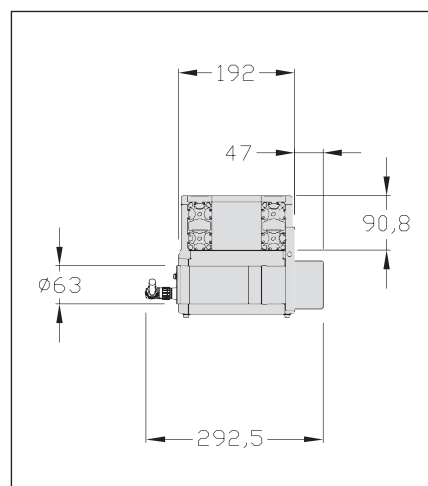
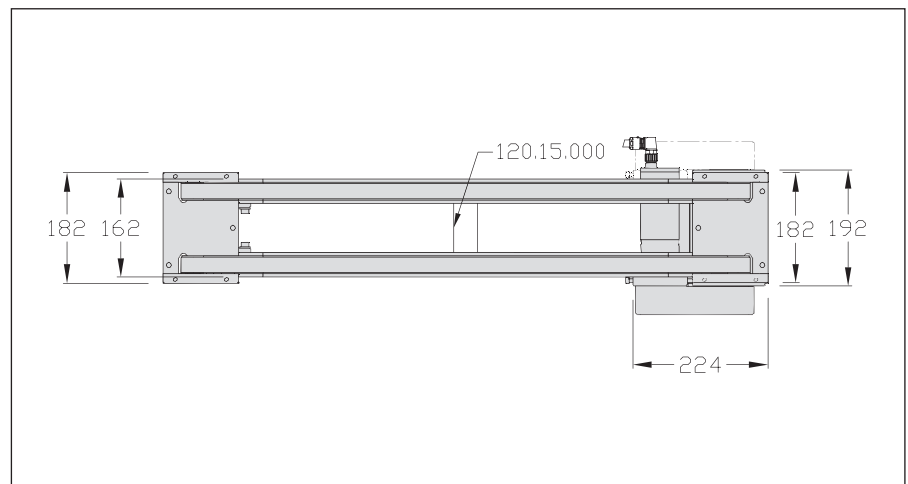
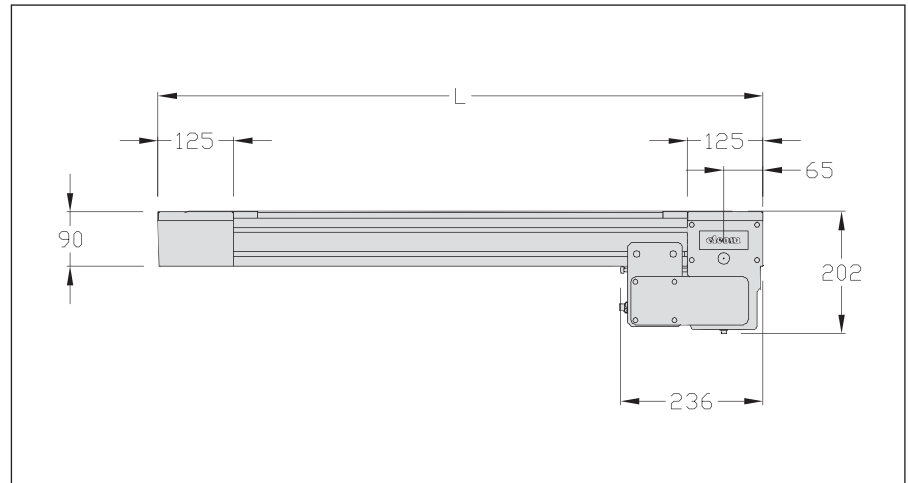

**elcom ITS 24 V**

Designation / Dimensions	Order unit	Reference
Conveying unit 24 V 200	1 pce	120.11.000.E
Conveyor length	m	120.11.000.A

## Conveying units Pushing motor Widths 200-300-400

### Technical data

Length mini L = 500 mm  
 Length maxi L = 6 250 mm

For longer spans and according to the load, use several conveying units.

### Conveying unit including

- ✘ 1 idling unit
- ✘ 1 driving unit  
 speed 9, 15 or 19 m/min
- ✘ Motor 230/400 V three-phase
  - 0,25 KW (9 m/min) I: 0,7 A
  - 0,37 KW (15 m/min) I: 1,2 A
  - 0,55 KW (19 m/min) I: 1,4 A

### Conveyor length:

- ✘ 2 profiles 8 80x40, Al anodized
- ✘ 2 belt guides, PA black
- ✘ 2 belts width 25 mm



Maximum load /6 m: 100 daN  
 Maximum accumulation load  
 maxi /6 m: 50 daN

### Belt length in mm

$L_{\text{welded}} = [(L-100) \times 2 + 173] \times 0,98$

Weight:

200: 15,7 kg + 6,7 kg /m  
 300: 18,5 kg + 6,7 kg /m  
 400: 21,1 kg + 6,7 kg /m

### Antistatic option

To be ordered with the initial assembling:

- 2 shouldered screws
- 2 steel rollers

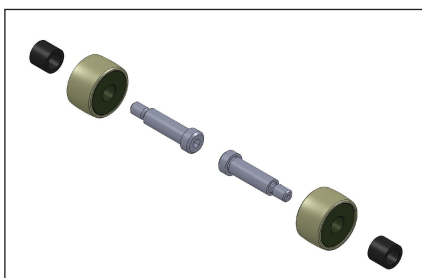
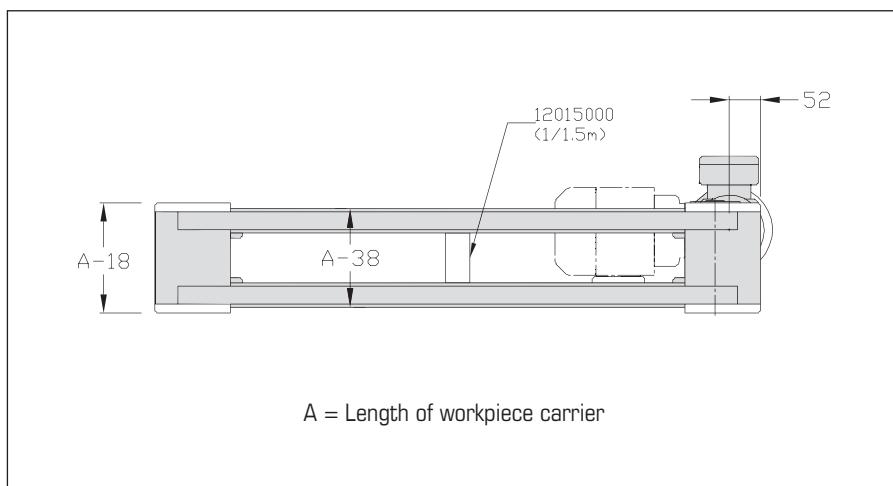
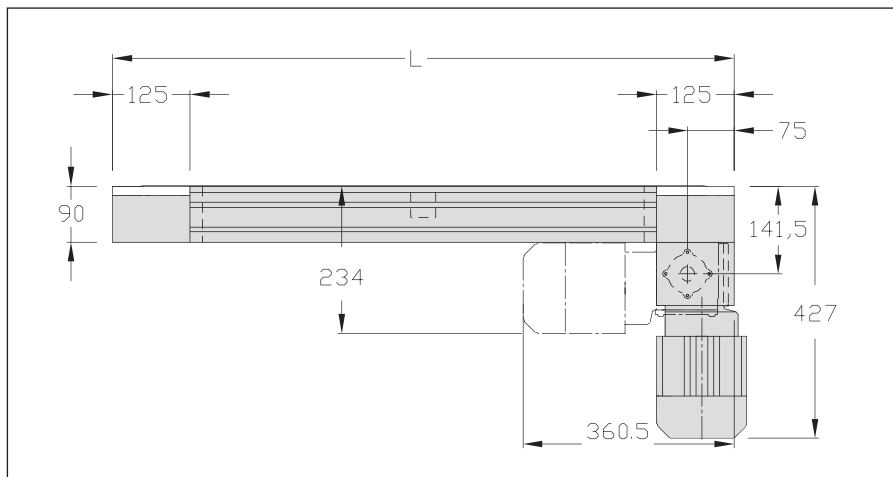

Designation / Dimensions	Order unit	Reference
Conveying unit 200 pushing motor	1 pce	120.02.000.P.**
Conveying unit 300 pushing motor	1 pce	130.02.000.P.**
Conveying unit 400 pushing motor	1 pce	140.02.000.P.**
Conveying length	m	120.02.000.A
Antistatic set	1 set	120.02.000.C

(\*\* = speed of motor m/min: 9-15 or 19 eg: 120.02.000.P.09)

## Direct conveying unit Width 200

### Technical data

Length mini L = 500 mm  
Length maxi L = 6 250 mm

For longer spans and according to the load, use several conveying units.

### Conveying unit including

- ✗ 1 idling unit
- ✗ 1 driving unit
  - speed 9, 15 or 19 m/min
- ✗ Motor 230/400 V three-phase
  - 0,25 KW (9 m/min) I: 0,7 A
  - 0,37 KW (15 m/min) I: 1,2 A
  - 0,55 KW (19 m/min) I: 1,4 A

### Conveyor length

- ✗ 2 profiles 8 80x40, Al anodized
- ✗ 2 belt guides, PA black
- ✗ 2 belts width 25 mm
  - thickness 1,8 mm, welded



Maximum load /6 m: 120 daN  
Maximum accumulation load /6 m:  
60 daN

### Belt length in mm

L welded = [(L-250) x 2 + 733] x 0,98

Weight: 16,5 kg + 6,7 kg/m

### Antistatic option

To be ordered with the initial assembling:

- 2 shouldered screws
- 2 steel rollers

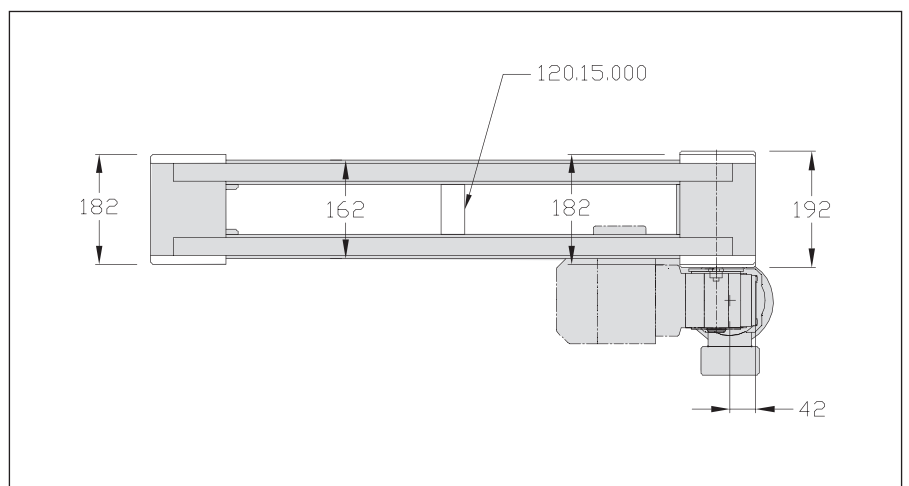
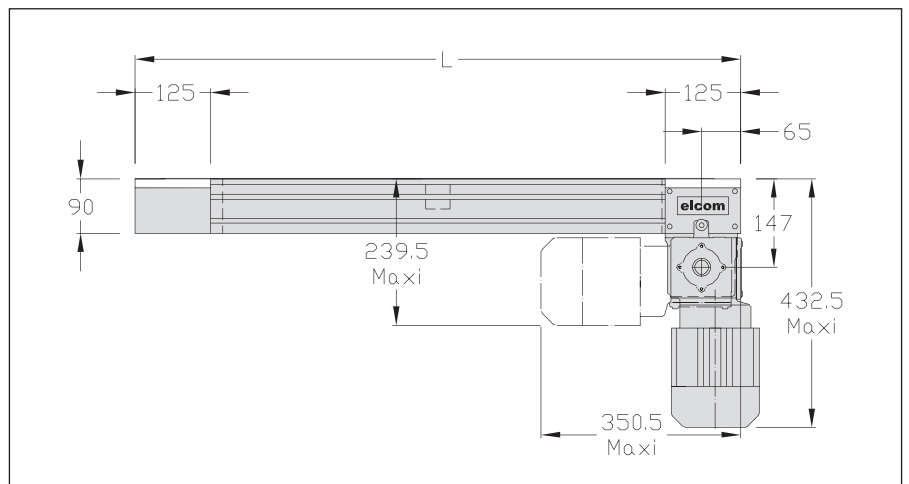
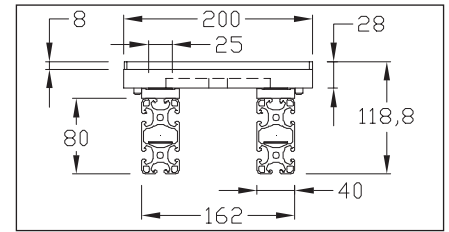
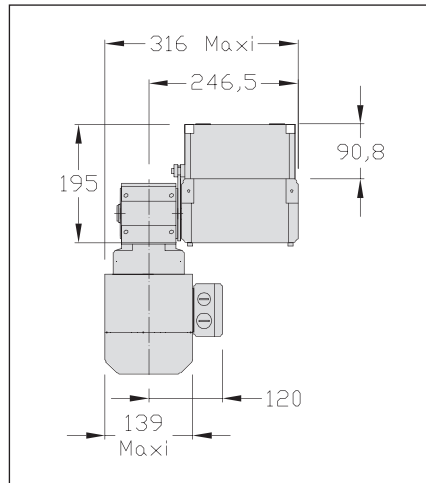

Designation / Dimensions	Order unit	Reference
Direct conveying unit 200	1 pce	120.11.000.**
Conveying length	m	120.11.000.A
Antistatic set	1 pce	120.02.000.C

(\*\* = speed of motor m/min: 9, 15 or 19 eg: 120.11.000.09)



## Height reductions Widths 200-300-400

### APPLICATIONS

For ergonomic manual stations (from a seated position). Enable reduction of the height of the conveyor in front of the worker.

#### Technical data

Including:

- ✘ 2 spacers
- ✘ 2 reducing PA
- ✘ 1 profile 40x16
- ✘ 1 conduit profile 40x20

For flat belt only.

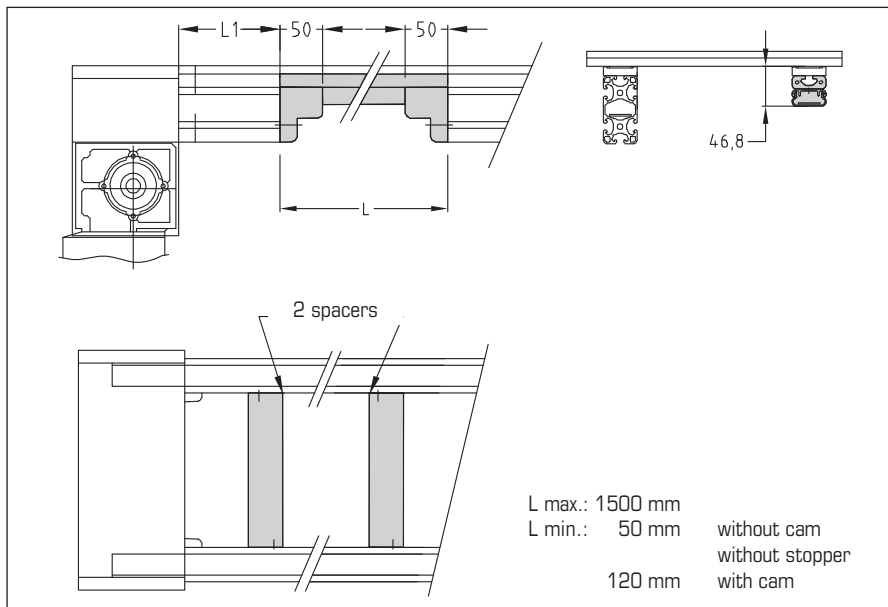

Designation / Dimensions	Order unit	Reference
Height reduction 200	1 pce	120.98.000
Height reduction 300	1 pce	130.98.000
Height reduction 400	1 pce	140.98.000

## Conveyor cut

### APPLICATIONS

The cut allows division of the conveyor lengths to make the transport and installation easier.

It also enables the making of important lengths when the load is limited.

#### Technical data

- ✘ Maximum length: 12 m
- ✘ 6 double universal fastenings 8

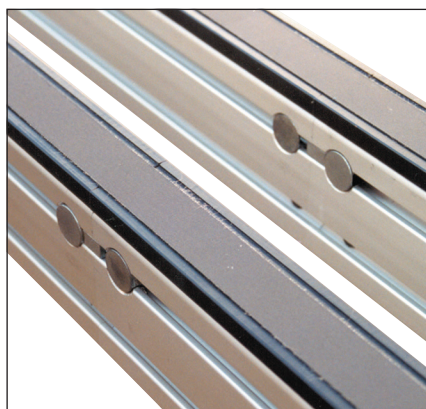

Lengths	Loads	
	Maxi daN	Accumulation maxi daN
TLM 2000		
7 m	180	90
8 m	160	80
9 m	140	70
10 m	120	60
11 m	100	50
12 m	80	40

Designation / Dimensions	Order unit	Reference
Conveyor cut 200-300-400	1 cut	120.02.000B

## Cap 200

### APPLICATIONS

Allows to protect the direct driving unit and the idling unit.  
When using cam, the opposite cap is delivered with the cam set.  
Also used for motorization 120.02.000.

#### Technical data

**x** 2 parts, PA black

Weight: 0,07 kg

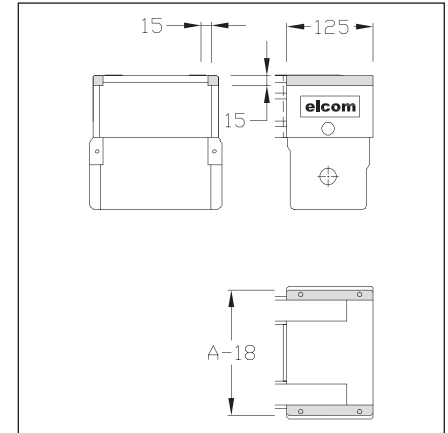

## Cap for motorization light timing belt

### APPLICATIONS

Allows to protect the light timing belt driving unit and the idling unit.  
When using cam, the opposite cap is delivered with the cam set.

#### Technical data

**x** 1 part and 1 symmetric part, PA black

Weight: 0,07 kg

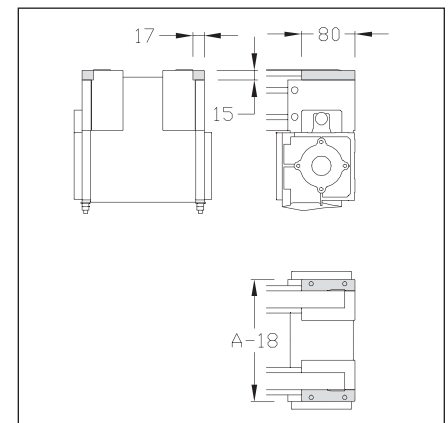

## Cap for motorization heavy timing belt

### APPLICATIONS

Allows to protect the heavy timing belt driving unit and the idling unit. When using cam, the opposite cap is delivered with the cam set.

#### Technical data

**x** 1 part and 1 symmetric part, PA black

Weight: 0,07 kg

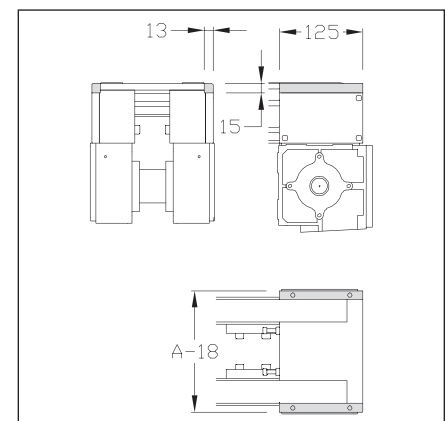

Designation / Dimensions	Order unit	Reference
Cap 200	1 kit	120.11.100
Cap for motorization light timing belt	1 kit	120.87.100
Cap for motorization heavy timing belt	1 kit	120.80.100

## Straight joining for driving unit flat belt

### APPLICATIONS

Allows to join end to end two conveying units.

#### Technical data

- x** Guide PA black
- x** Joining set alu

Weight: 0,18 kg

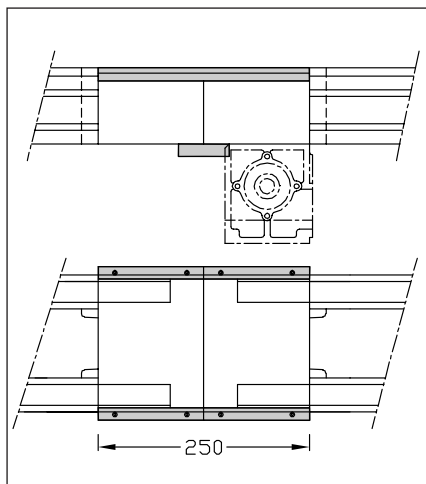

## Straight joining for direct driving unit

### APPLICATIONS

Allows to join end to end two conveying units.

#### Technical data

- x** Guide PA black
- x** Joining set alu

Weight: 0,2 kg

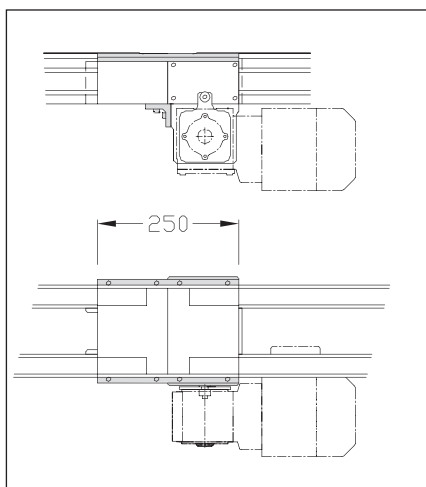

Designation / Dimensions	Order unit	Reference
<b>Straight joining 200-300-400</b>	<b>1 set</b>	<b>120.18.000</b>
<b>Straight joining for direct driving unit</b>	<b>1 set</b>	<b>120.18.000.SC</b>

## Straight joining for motorization light timing belt

### APPLICATIONS

Allows to join end to end two conveying units.

#### Technical data

- x** Guide PA black
- x** Joining set alu

Weight: 0,18 kg

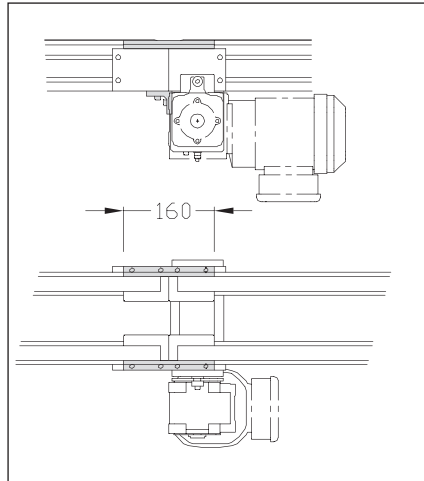

## Straight joining for motorization heavy timing belt

### APPLICATIONS

Allows to join end to end two conveying units.

#### Technical data

- x** Guide PA black
- x** Joining set alu

Weight: 0,2 kg

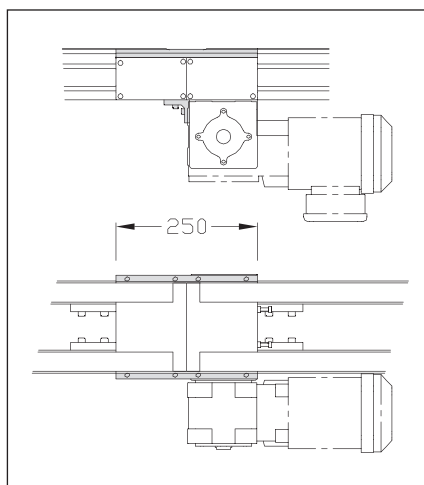

Designation / Dimensions	Order unit	Reference
Straight joining for motorization light timing belt	1 set	120.89.000
Straight joining for motorization heavy timing belt	1 set	120.82.000

## Spacers Widths 200-300-400

### APPLICATIONS



If the length of the conveying unit is >1,5 m, spacers have to be fitted between the profiles 8 80x40. (1 spacer /1,5 m).

### Technical data

#### Width 200:

- x Cast aluminium
- x 2 universal fastenings

#### Widths 300 and 400:

- x Profile 8 40x40 light
- x 2 universal fastenings

Weight: 200: 0,18 kg  
300: 0,40 kg  
400: 0,55 kg

Spacer 200



Spacer 300-400



Designation / Dimensions	Order unit	Reference
Spacer 200	1 pce	120.15.000
Spacer 300	1 pce	130.15.000
Spacer 400	1 pce	140.15.000

## Half junctions Widths 200-300-400

### APPLICATIONS

For TLM 2000, widths 200 , 300 and 400, flat belt.

Half junctions allow a workpiece carrier to go out at the end of the line either on the driving or the idling side.

### Technical data

- ✘ 2 parts, PA black
- ✘ Fastening parts
- ✘ Chain cover with slope

Weight: 200: 0,3 kg  
300: 0,4 kg  
400: 0,5 kg

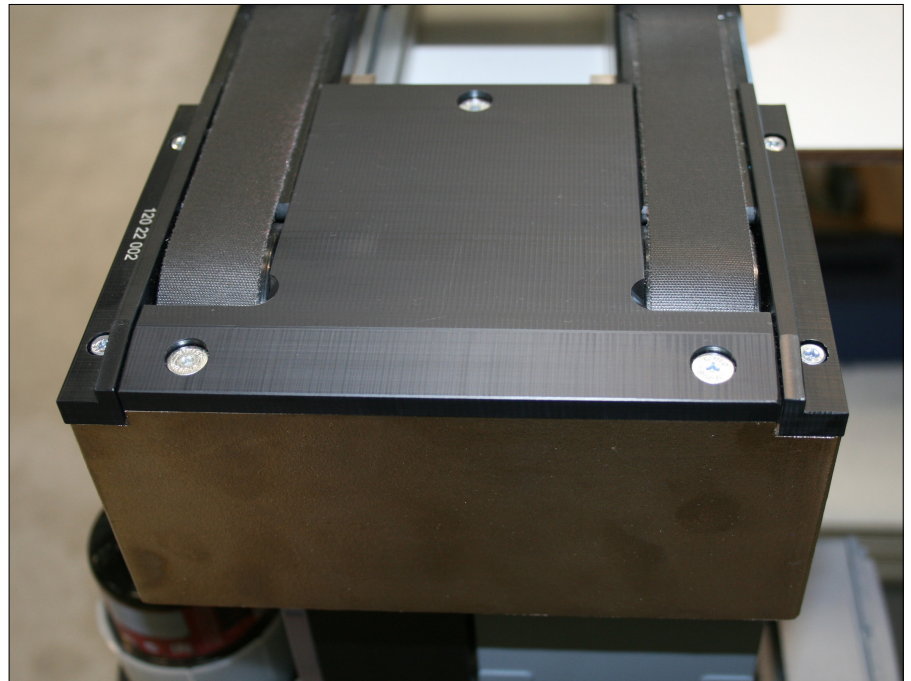
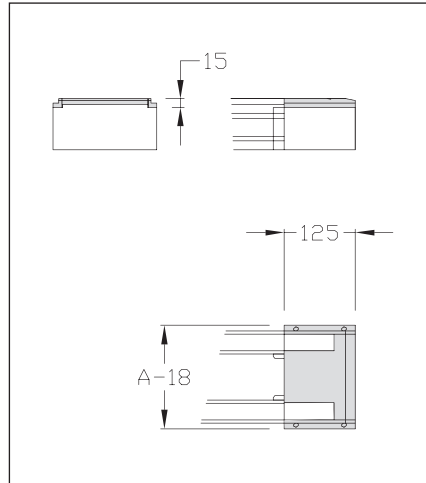

Designation / Dimensions	Order unit	Reference
Half junction flat belt 200	1 set	120.22.000
Half junction flat belt 300	1 set	130.22.000
Half junction flat belt 400	1 set	140.22.000



## Returns 180°

### APPLICATIONS

Allows the return of the workpiece carrier on a parallel conveyor with a reduced space between the two conveyors. The workpiece carrier is conveyed always keeping the same side towards the outside of the line.

To facilitate the maintenance, the gear motor is identical to the driving units motors.

**Do not accumulate workpiece carriers in the returns.**

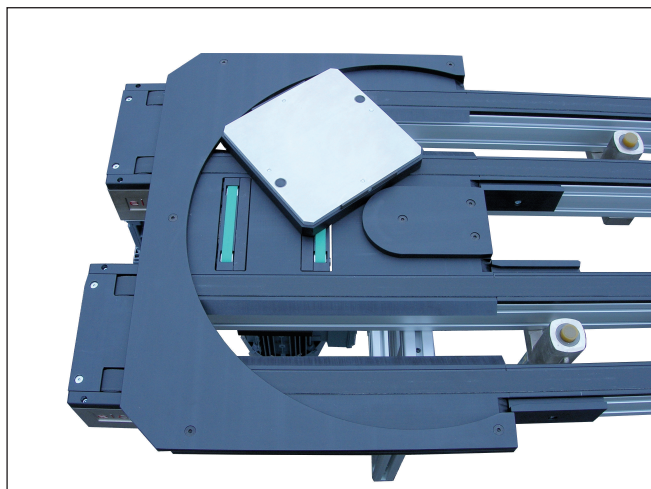

Return 180° width 300

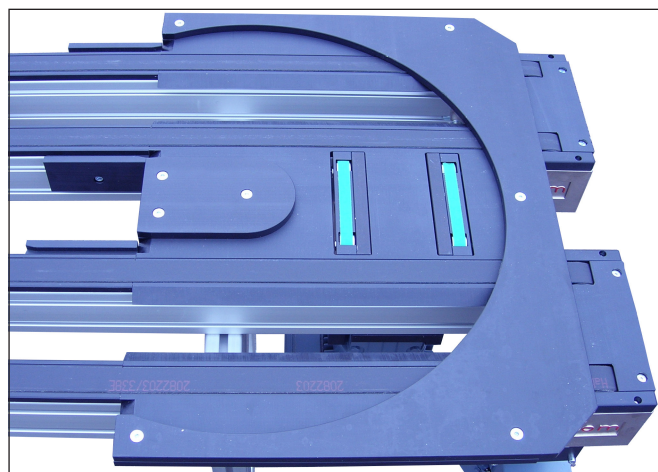

Return 180° width 200

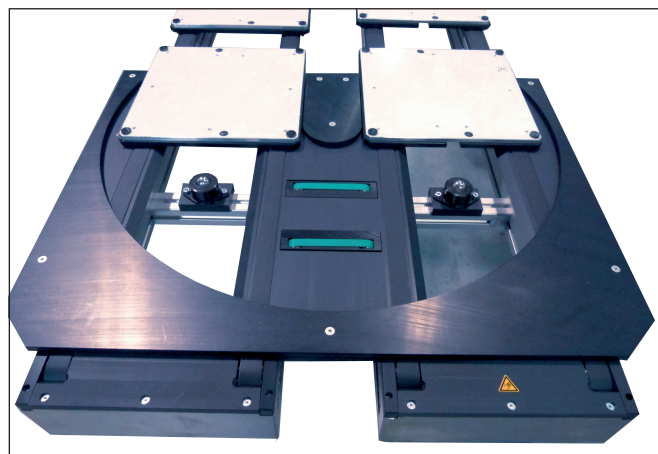

Return 180° width 300

## Returns 180° Widths 200-300

### Technical data

- ✘ Motor plates, Al black
- ✘ 2 parallel belts driven by a gear motor
- ✘ Plates and lateral guide supports, PA black
- ✘ Screws and bolts

**Just for rectangular workpiece carriers 200 and 300.**



Do not accumulate the workpiece carriers in the returns.

Weight: 200: 16 kg  
300: 18,2 kg

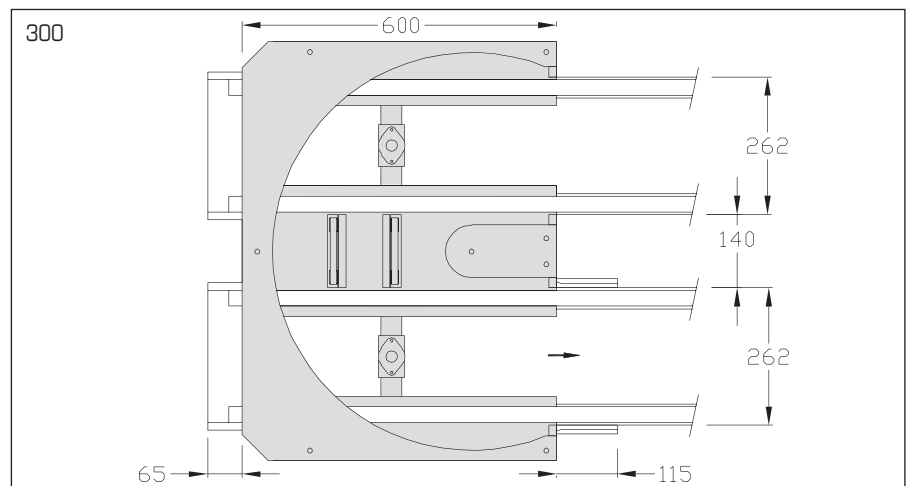
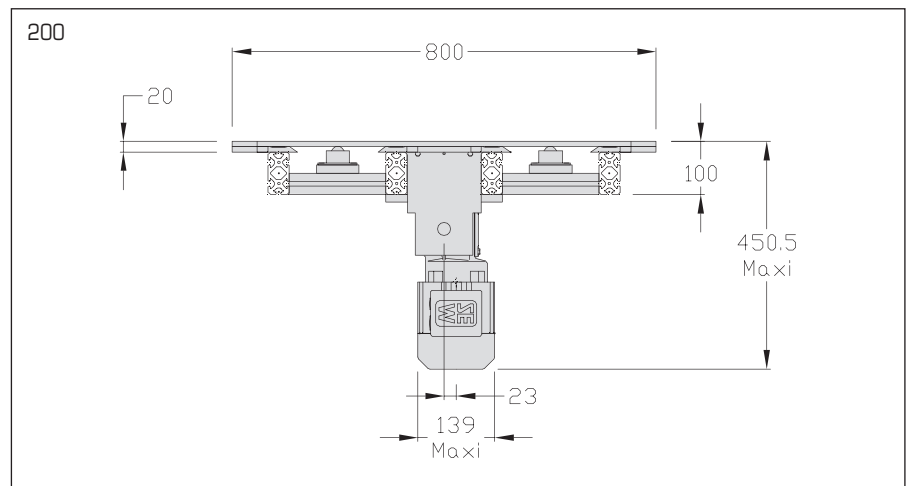
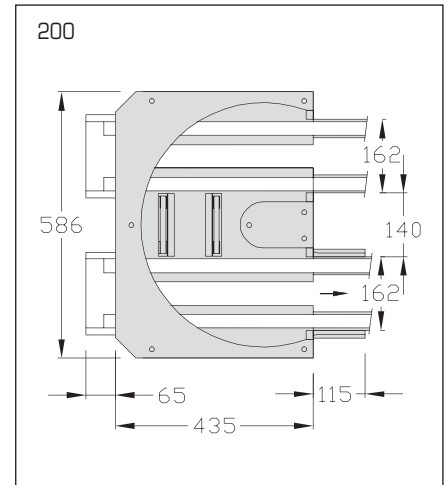
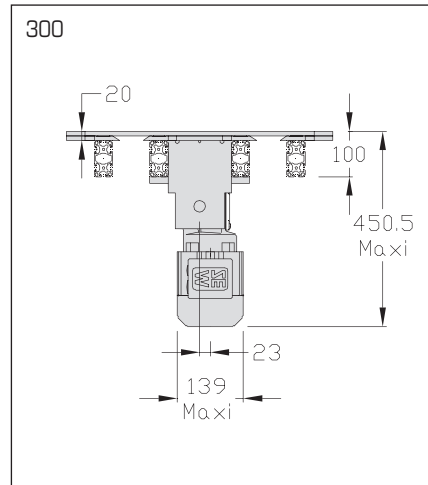

TLM 2000

Designation / Dimensions	Order unit	Reference
<b>Return 180°-200</b>	<b>1 pce</b>	<b>120.34.000.**</b>
<b>Return 180°-300</b>	<b>1 pce</b>	<b>130.34.000.**</b>

(\*\* = speed of motor m/min: 9, 15 or 19 eg: 120.34.000.09)

## Return 180° Width 200 Length 250

### Technical data

- ✗ Motor plates, Al black
- ✗ 2 parallel belts driven by a gear motor on a conveyor unit
- ✗ Plate and lateral guide, PA black
- ✗ Screws

**For rectangular workpiece carriers 200x250 only.**



Do not accumulate the workpiece carriers in the returns.

Weight: 16 kg

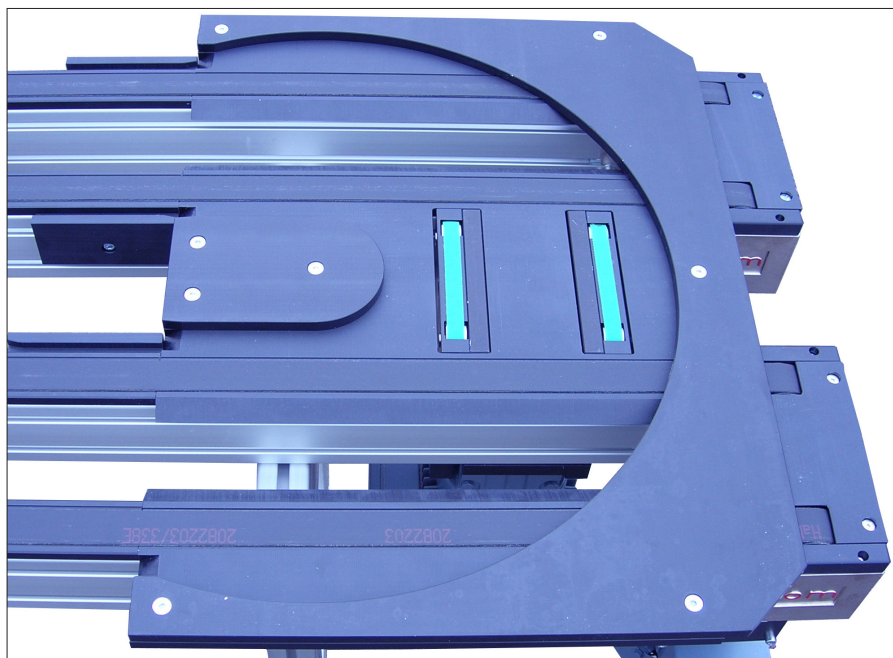
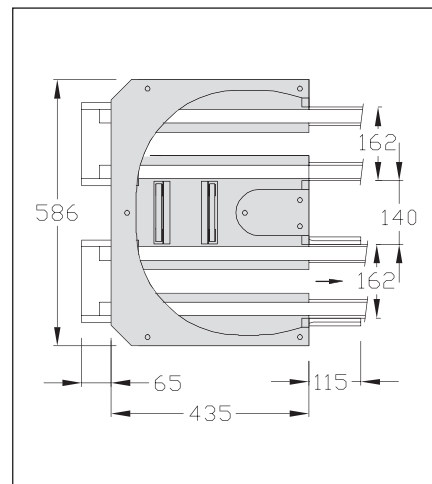
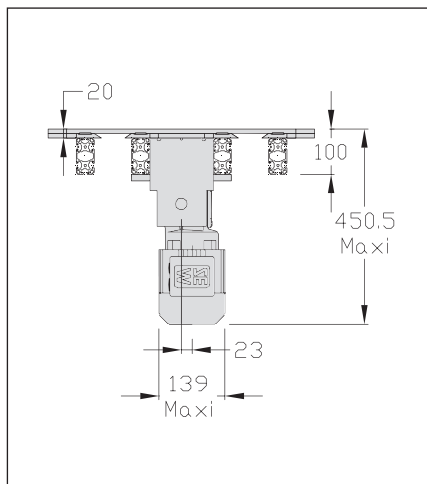

**Designation / Dimensions**

**Return 180° 200 x 250**

**Order unit**

**1 pce**

**Reference**

**125.34.000.\*\***

(\*\* = speed of motor m/min: 9-15 or 19 eg: 125.34.000.09)

## Return 180° Width 400

### Technical data

- ✘ Motor plates, Al black
- ✘ 2 parallel belts driven by a gear motor
- ✘ Plates and lateral guide supports, PA black.
- ✘ Screws and bolts

**For square workpiece carriers  
400x400 only.**

 Do not accumulate the workpiece carriers in the returns.

Weight: 20 kg

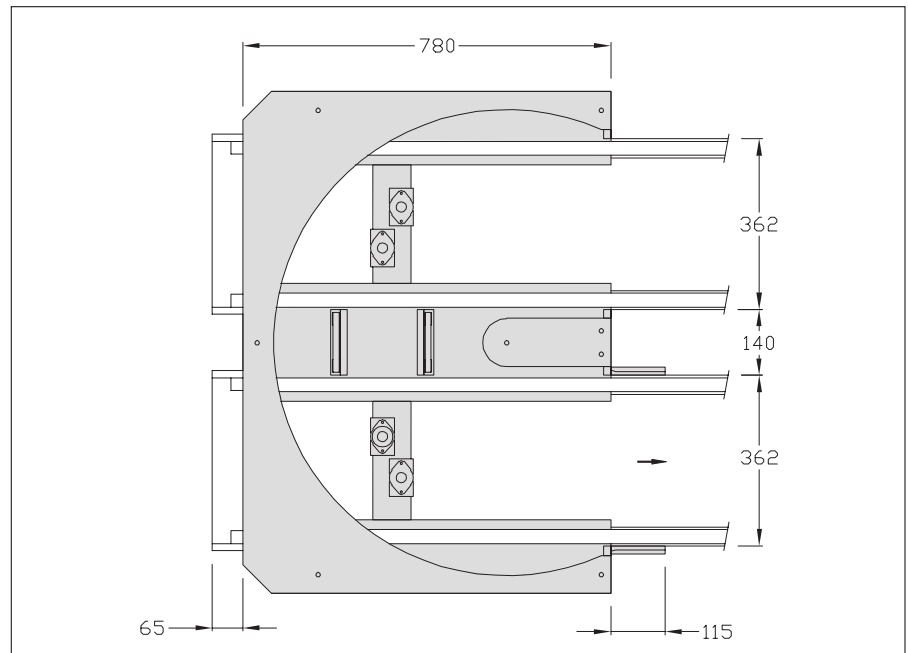
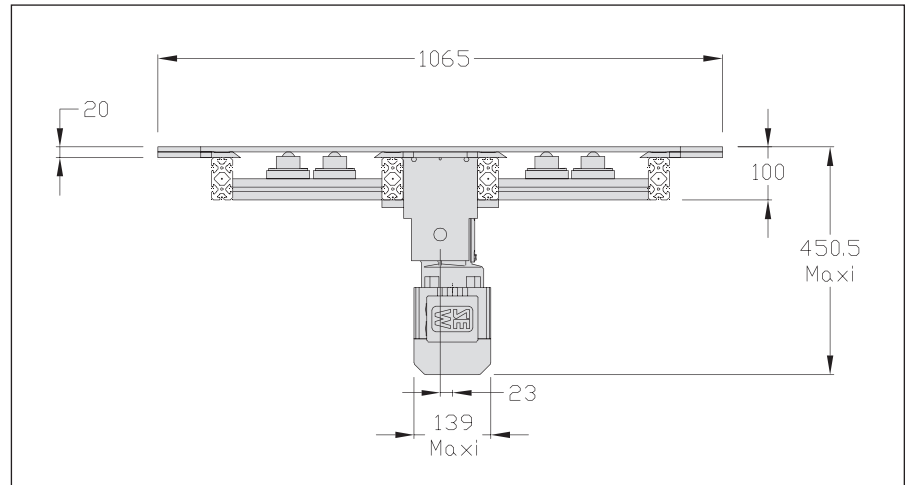

Designation / Dimensions	Order unit	Reference
<b>Return 180° 400</b>	<b>1 pce</b>	<b>140.34.000.**</b>

(\*\* = speed of motor m/min: 9, 15 or 19 eg: 140.34.000.09)

## Chain lubrication sets

### APPLICATIONS

Allow the automatic chain lubrication of the driving chain of the conveying unit TLM 2000 pushing motor (120.02.000P – 130.02.000.P – 140.02.000P) for 12 months.

### Technical data

- ✗ Oil cartridge ref. 900.00.106
- ✗ Batteries (to be changed every 12 months) ref. 900.00.108
- ✗ Oil for chain SO14

0,13 cm<sup>3</sup> by injection

Weight: 1,2 kg

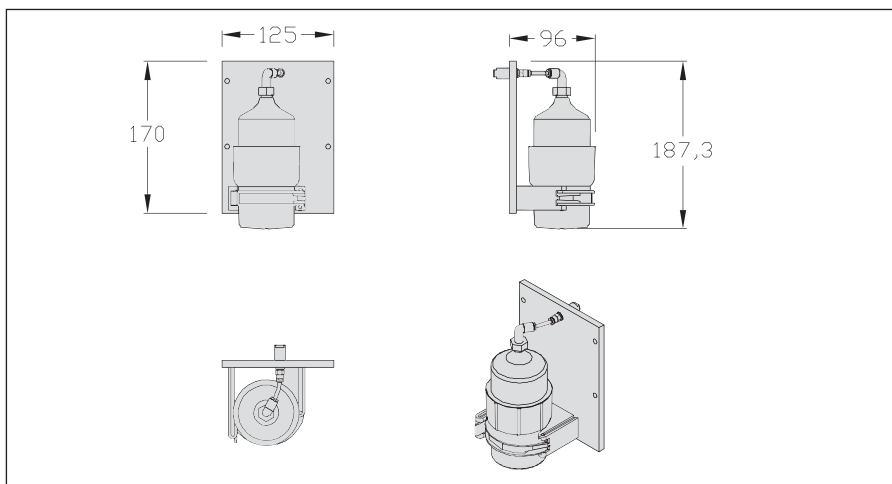
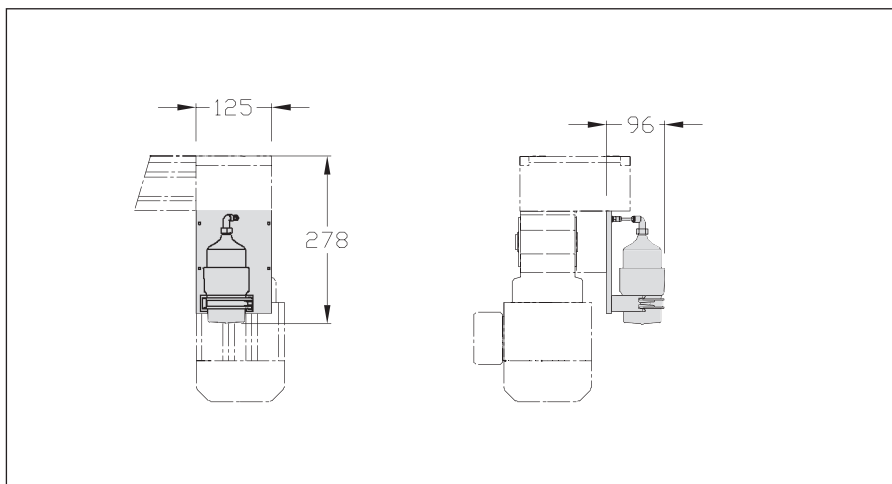
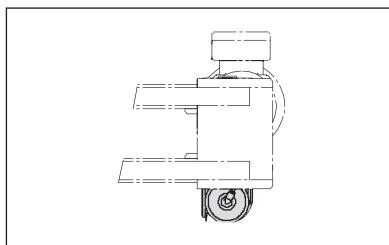

Designation / Dimensions	Order unit	Reference
Chain lubrication set	1 set	900.00.100
Chain lubrication set pushing motor	1 set	900.00.100.P



# Lifts

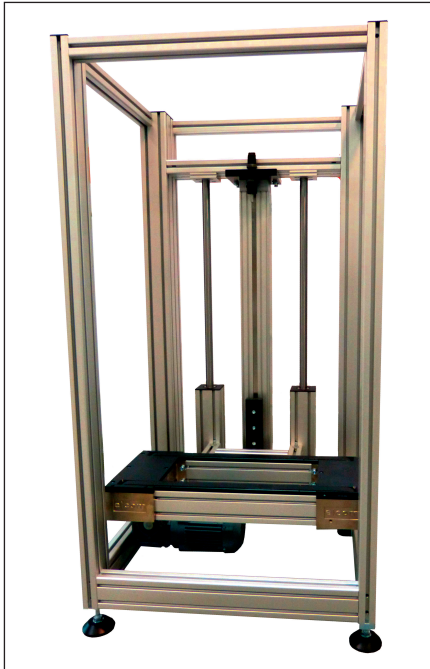

Bridge built from two transfer systems

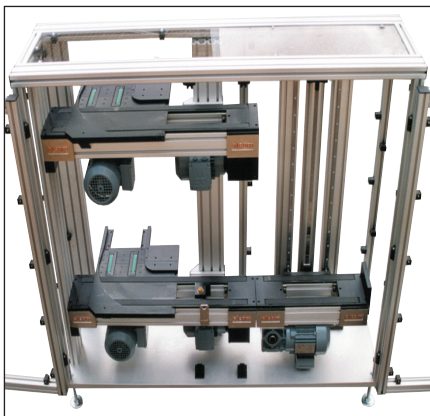

Angle transfer system-upper or basement type  
(pneumatic cylinder model)



Inclined transfersystem lift-upper or basement  
type



Lift for two transfer system units  
(from 1000 mm to 3000 mm)

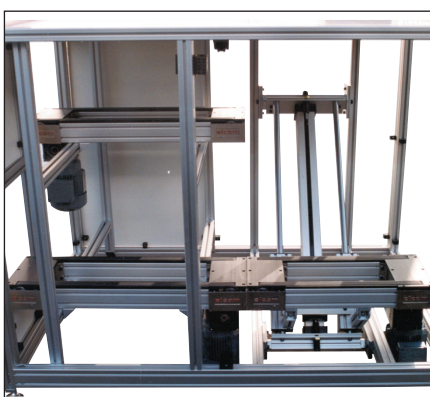

Inclined transfersystem lift-upper or basement  
type (with pneumatic cylinder)



## Lifts Widths 200 -300 -400

Allow the return of workpiece carriers above or below a line or the distribution of workpiece carriers on several levels.

Manufactured from standard elements, each lift is adapted to the size of the workpiece carriers, the strokes and other line-specific parameters.

### Technical data

- ✘ Frame
- ✘ Guides + lifting cylinder
- ✘ Waiting area for conveyors

### Dimensions

- H = Lifting height
- L = Length of moving conveyor
- H1 = Minimum height of conveyor 300 mm
- H2 = (if workpiece carrier height < 280 mm)  $H1+H+280$
- H2 = (if workpiece carrier height > 280 mm)  $H1+H$
- L1 = Total length of lift  
( $L = L+40$  mm)
- l = Depth of lift  
(Conveyor width + 360 mm)

Lift type (workpiece carrier entry/exit)

- EG-SG (left entry/left exit)
- ED-SD (right entry/right exit)
- EG-SD (left entry/right exit)
- ED-SG (right entry/left exit)

Maximum load: 20 kg

Speed of cylinder stroke: 1m/s

The protective housings for conveyors are not included in the delivery.

On request: timing belt drive or ball-and-screw drive.

Asynchronous or brushless motorization.

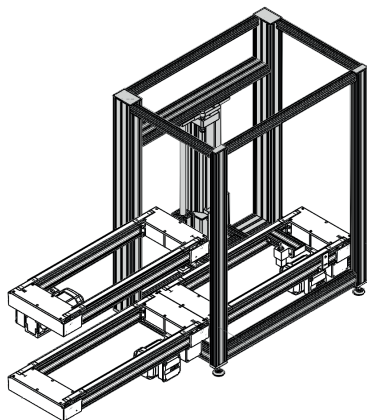
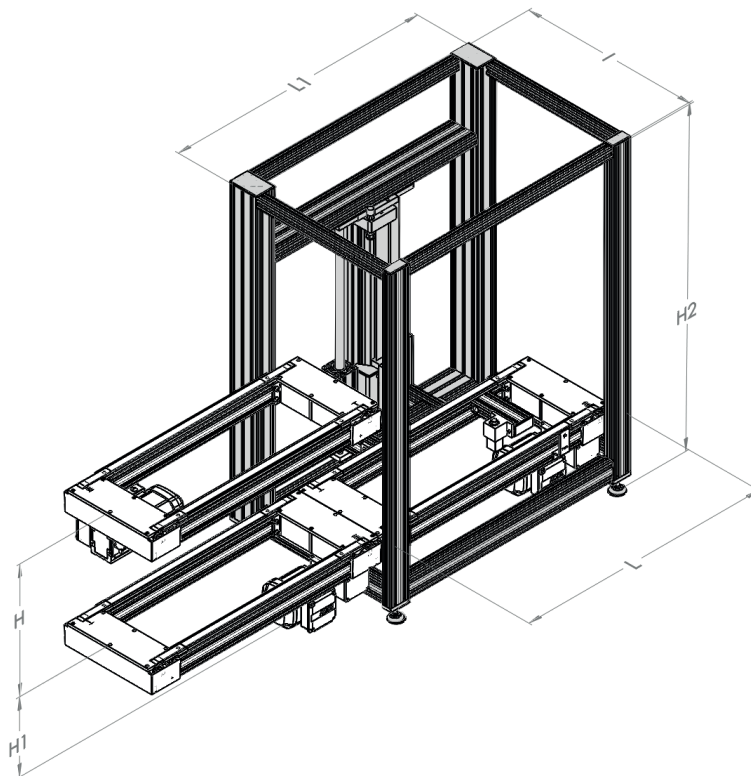

Type EG-SG

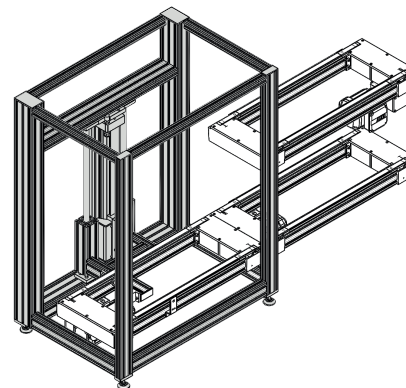

Type ED-SD

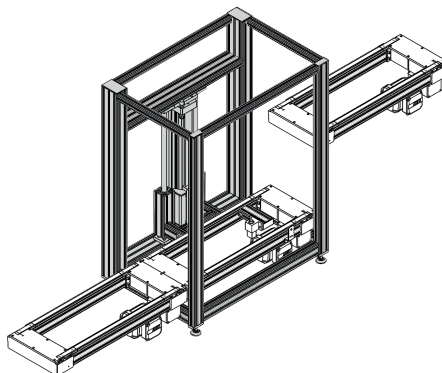

Type EG-SD

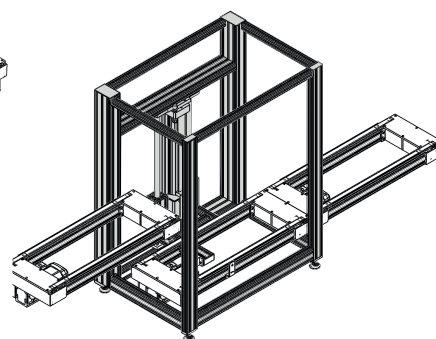

Type ED-SG

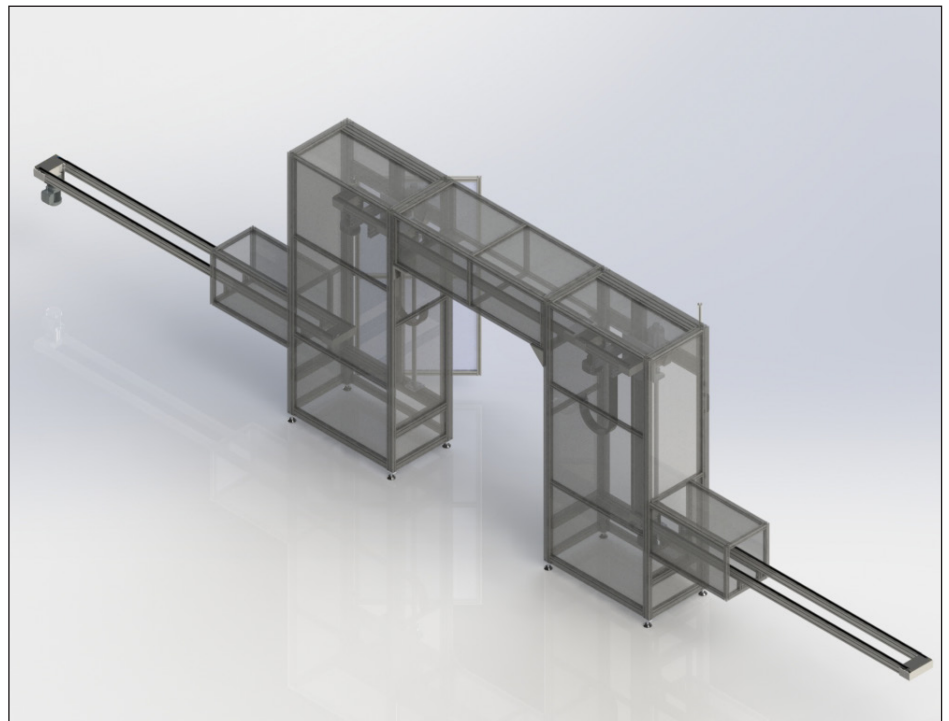

Electrical version of the ballscrew on request.

Designation / Dimensions	Order unit	Reference
<b>Lift 200</b>	<b>1 pce</b>	<b>120.57.000</b>
<b>Lift 300</b>	<b>1 pce</b>	<b>130.57.000</b>
<b>Lift 400</b>	<b>1 pce</b>	<b>140.57.000</b>

## Cams 90°

### Cams ED, EG, SD, SG for conveying units flat belt.

They allow a perpendicular transfer of workpiece carriers from one conveying unit to the other.

The workpiece carrier is guided by the two inside pins, the outside pins are retracted.

Can also be used for derivations.

### Cams ED, EG, SD, SG for conveying units timing belt.

They allow a perpendicular transfer of workpiece carriers from one conveying unit to the other.

The workpiece carrier is guided by the two inside pins, the outside pins are retracted.

No automatism is required.

If a selection is necessary (derivation or not), add the derivation set



**Do not accumulate workpiece carriers in cams.**

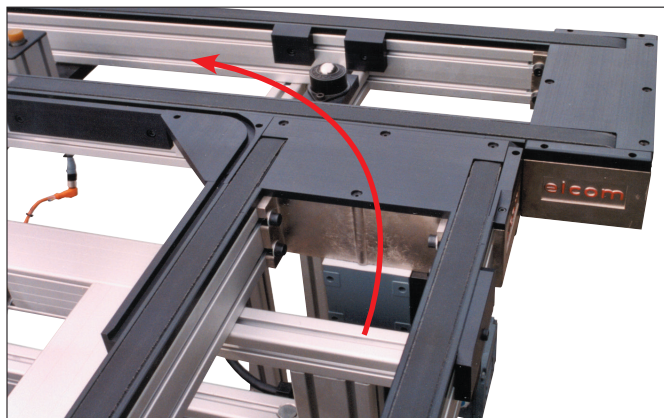

Cam EG

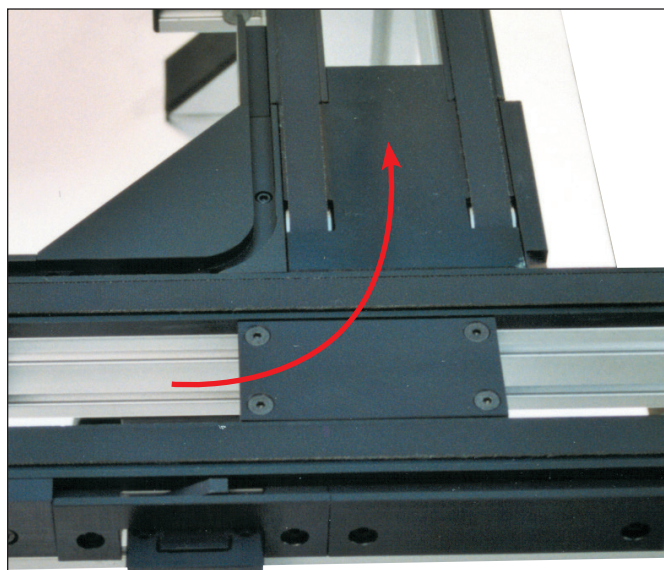

Cam SG

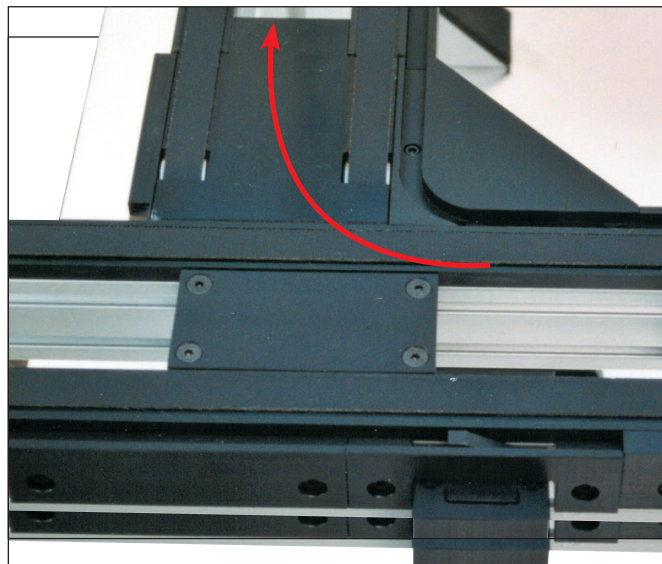

Cam SD

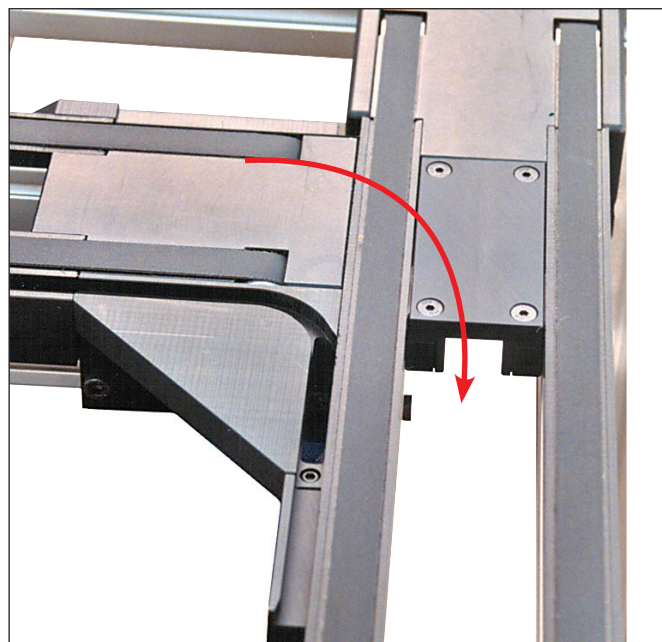

Cam ED



## Cams 90° Widths 200-300-400

### Technical data

Complete set including:

- ✗ Guiding cam, PA black
- ✗ Pin retracting plates, PA black
- ✗ Fastening parts
- ✗ Joining parts
- ✗ Caps

Different cams according to the dimensions of the workpiece carriers.

The cams 200 allow also the use of workpiece carriers 200x250 and 200x300.

The cams 300 allow also the use of workpiece carriers 300x400.

If a selection is necessary (derivation or not), add the derivation set



Do not accumulate the workpiece carriers in the cams.

Weight: 200: 0,91 kg  
300: 1,5 kg  
400: 1,9 kg

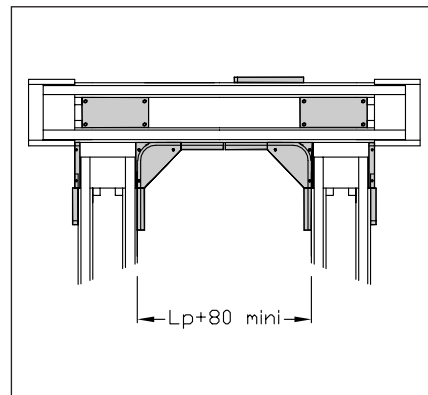
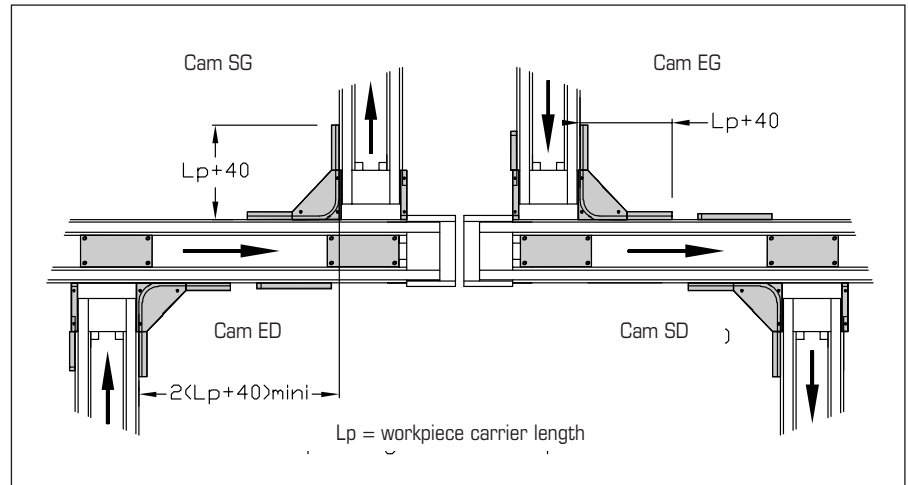

Cam ED Right inlet on main line  
Cam SD Right outlet on main line

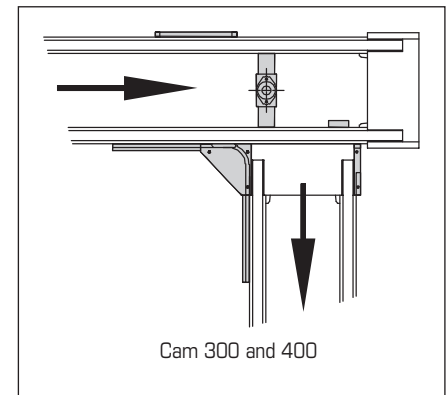

Cam EG Left inlet on main line  
Cam SG Left outlet on main line

Designation / Dimensions	Order unit	Reference
<b>Cam 90° ED 200</b>	<b>1 set</b>	<b>120.06.000</b>
<b>Cam 90° EG 200</b>	<b>1 set</b>	<b>120.16.000</b>
<b>Cam 90° SD 200</b>	<b>1 set</b>	<b>120.26.000</b>
<b>Cam 90° SG 200</b>	<b>1 set</b>	<b>120.36.000</b>
<b>Cam 90° ED 200 direct</b>	<b>1 set</b>	<b>120.06.000.SC</b>
<b>Cam 90° EG 200 direct</b>	<b>1 set</b>	<b>120.16.000.SC</b>
<b>Cam 90° ED 300</b>	<b>1 set</b>	<b>130.06.000</b>
<b>Cam 90° EG 300</b>	<b>1 set</b>	<b>130.16.000</b>
<b>Cam 90° SD 300</b>	<b>1 set</b>	<b>130.26.000</b>
<b>Cam 90° SG 300</b>	<b>1 set</b>	<b>130.36.000</b>
<b>Cam 90° ED 400</b>	<b>1 set</b>	<b>140.06.000</b>
<b>Cam 90° EG 400</b>	<b>1 set</b>	<b>140.16.000</b>
<b>Cam 90° SD 400</b>	<b>1 set</b>	<b>140.26.000</b>
<b>Cam 90° SG 400</b>	<b>1 set</b>	<b>140.36.000</b>

## Cams 90° timing belt, light motorization Width 200

### Technical data

Complete set including:

- ✘ Guiding cam and pin retracting plates, PA black
- ✘ Fastening parts
- ✘ Joining parts
- ✘ Caps

The cams 200 allow also the use of workpiece carriers 200x250 and 200x300.

If a selection is necessary (derivation or not), add the derivation set.



Do not accumulate the workpiece carriers in the cams.

Weight: 1 kg

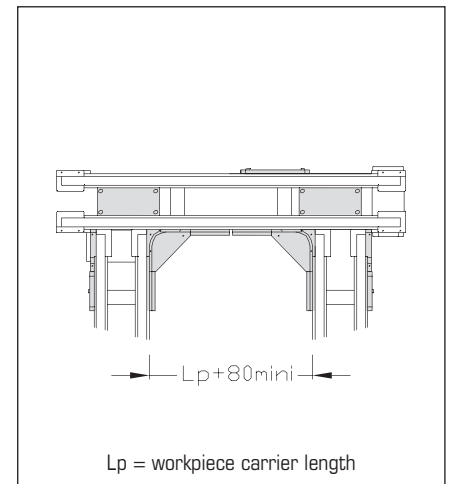
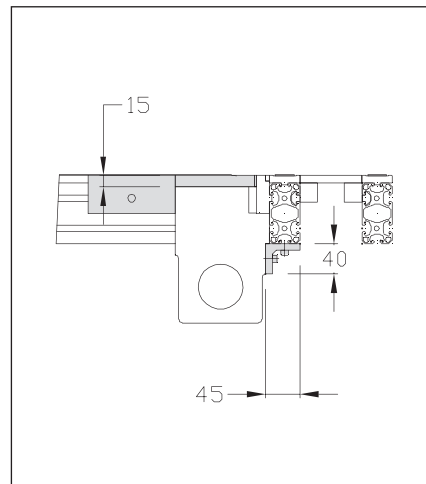
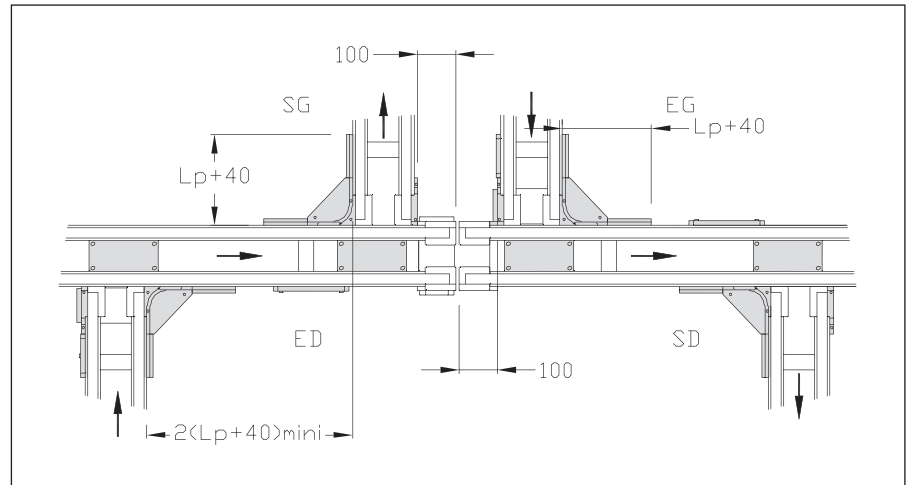

Designation / Dimensions	Order unit	Reference
Cam 90° ED 200 timing belt light motorization	1 pce	120.90.100
Cam 90° EG 200 timing belt light motorization	1 pce	120.90.200
Cam 90° SD 200 timing belt light motorization	1 pce	120.90.300
Cam 90° SG 200 timing belt light motorization	1 pce	120.90.400

# Cams 90° timing belt, heavy motorization Width 200

## Technical data

Complete set including:

- ✘ Guiding cam and pin retracting plates, PA black
- ✘ Fastening parts
- ✘ Joining parts
- ✘ Caps

The cams 200 allow also the use of workpiece carriers 200x250 and 200x300.

If a selection is necessary (derivation or not), add the derivation set.



Do not accumulate the workpiece carriers in the cams.

Weight: 1 kg

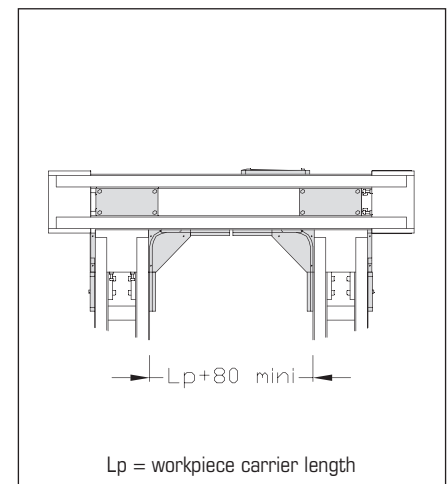
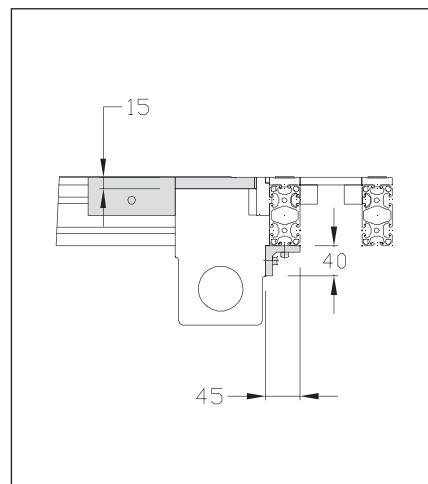
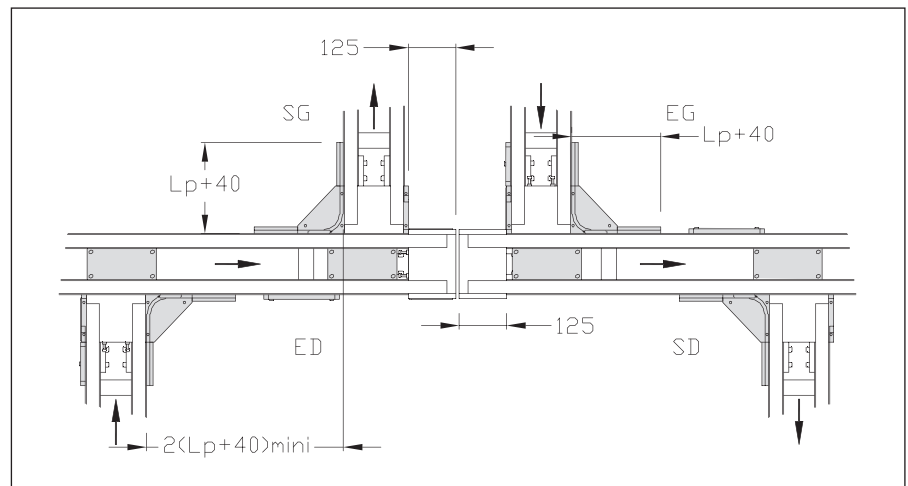

TLM 2000

Designation / Dimensions	Order unit	Reference
Cam 90° ED 200 timing belt heavy motorization	1 pce	120.83.100
Cam 90° EG 200 timing belt heavy motorization	1 pce	120.83.200
Cam 90° SD 200 timing belt heavy motorization	1 pce	120.83.300
Cam 90° SG 200 timing belt heavy motorization	1 pce	120.83.400



## Short cams and double cams

### Short cams SD-EG SG-ED - Double cams

The short cams and double cams allow deviation of workpiece carriers from a main line to a secondary line without additional motorization. Economical, compact and very easily managed, they are ideal to set up work stations in derivation.



**Do not accumulate the workpiece carriers in the cams.**



Short cam 200

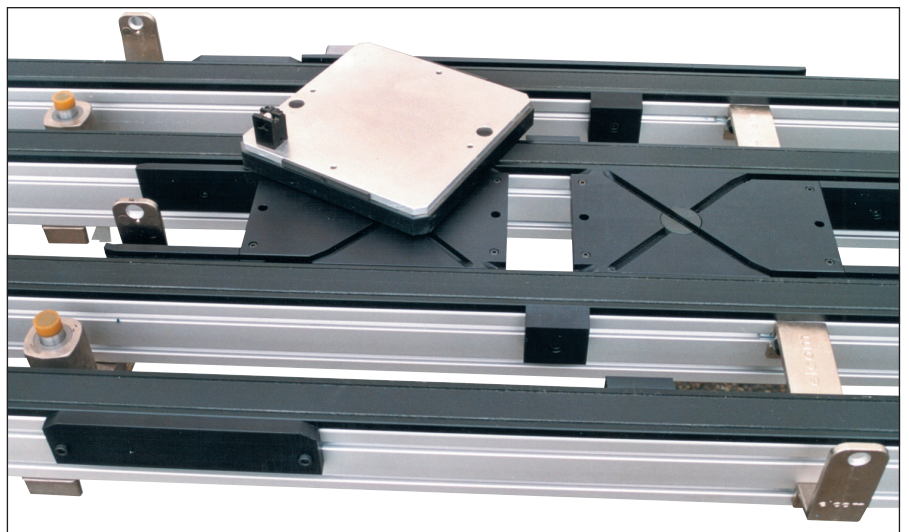

Double cam 200

## Short cams SD-EG, SG-ED Width 200

### Technical data

Complete set including:

- ✘ Cams and guides, PA black
- ✘ Fastening parts
- ✘ Screw and nut St M6

(1 set SD-EG + 1 set SG-ED are necessary to make a complete derivation)

They allow also the use of workpiece carriers 200x250 and 200x300.

If a selection is necessary (derivation or not), add the derivation set

Minimum load on workpiece carrier: 2 daN



Do not accumulate the workpiece carriers in the cams.

Weight: 2,2 kg

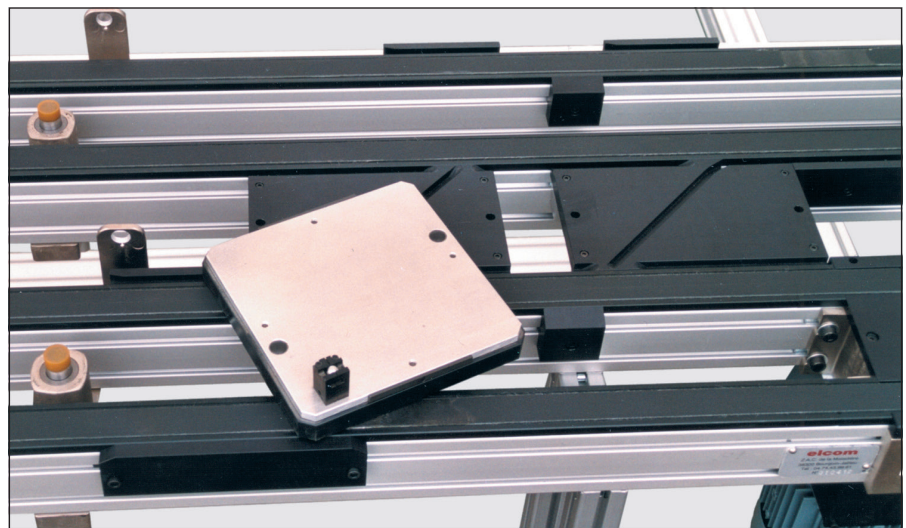
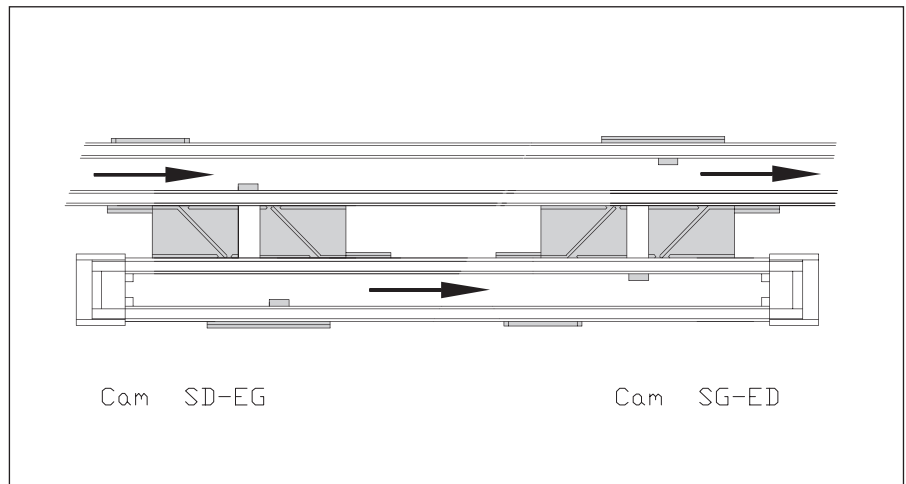
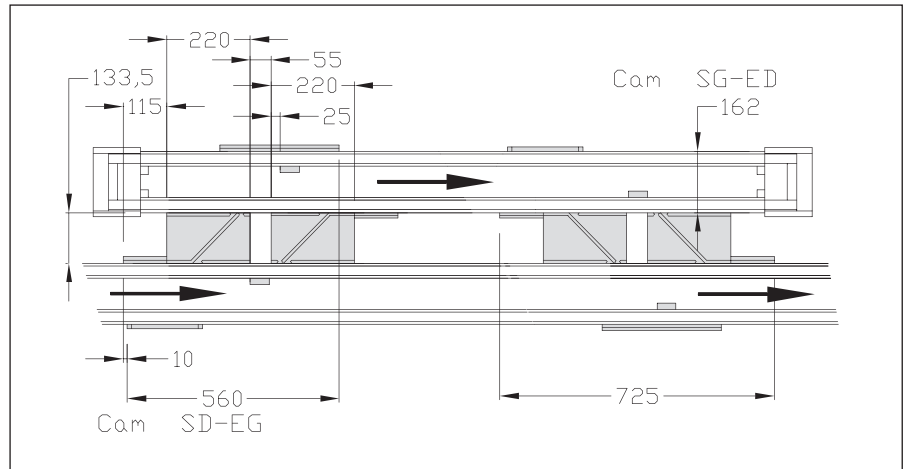

TLM 2000

Designation / Dimensions	Order unit	Reference
Short cam 200 SD-EG	1 set	120.46.000
Short cam 200 SG-ED	1 set	120.17.000

## Short cams SD-EG, SG-ED Widths 300-400

### Technical data

Complete set including:

- ✘ Cam and guides, PA black
- ✘ Fastening parts
- ✘ Screw and nut St M6

(1 set SD-EG + 1 set SG-ED are necessary to make a complete derivation)

The short cam 300 allow also the use of workpiece carriers 300x400.

If a selection is necessary (derivation or not) add the derivation set.



Do not accumulate the workpiece carriers in the cams.

Minimum load on workpiece carrier: 2 daN

Weight: Short cam 300: 6,1 kg  
Short cam 400: 13,2 kg

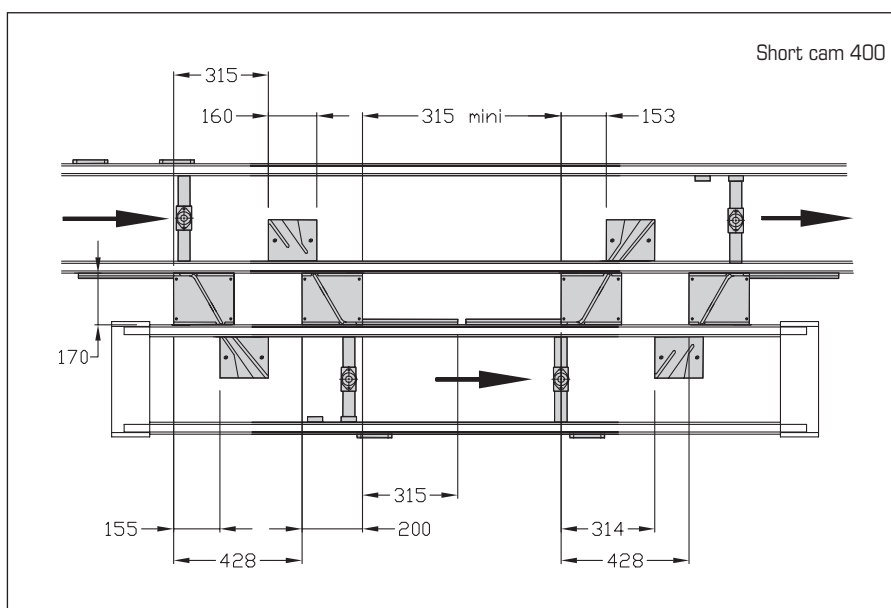
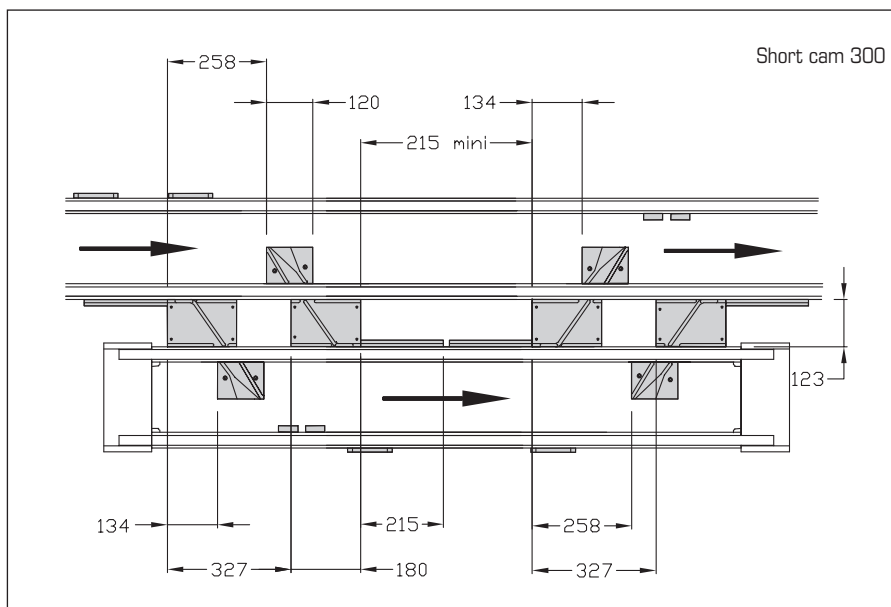

Designation / Dimensions	Order unit	Reference
Short cam 300 SD-EG	1 set	130.46.000
Short cam 300 SG-ED	1 set	130.17.000
Short cam 400 SD-EG	1 set	140.46.000
Short cam 400 SG-ED	1 set	140.17.000

## Double cam Width 200

### Technical data

Complete set including:

- ✘ Cam, selectors, ramps and guides, PA black
- ✘ 2 rotative cylinders, (M5)
- ✘ Fastening parts
- ✘ Screw and nut St M6

They allow also the use of workpiece carriers 200x250 and 200x300.

If a selection is necessary (derivation or not) add the derivation set

Minimum load on workpiece carrier: 2 daN



Do not accumulate the workpiece carriers in the cams.

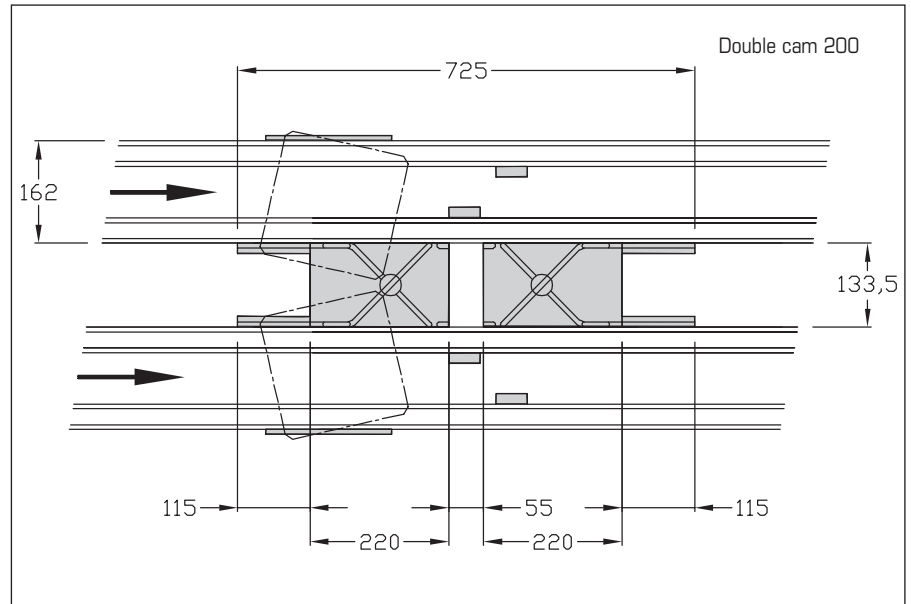

Weight: 3,6 kg

Designation / Dimensions	Order unit	Reference
Double cam 200	1 set	120.21.000

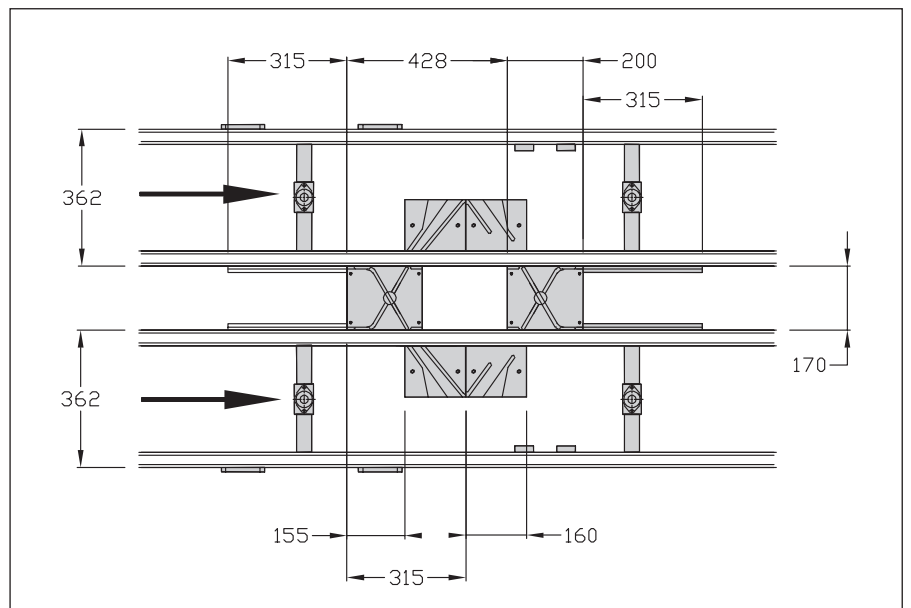
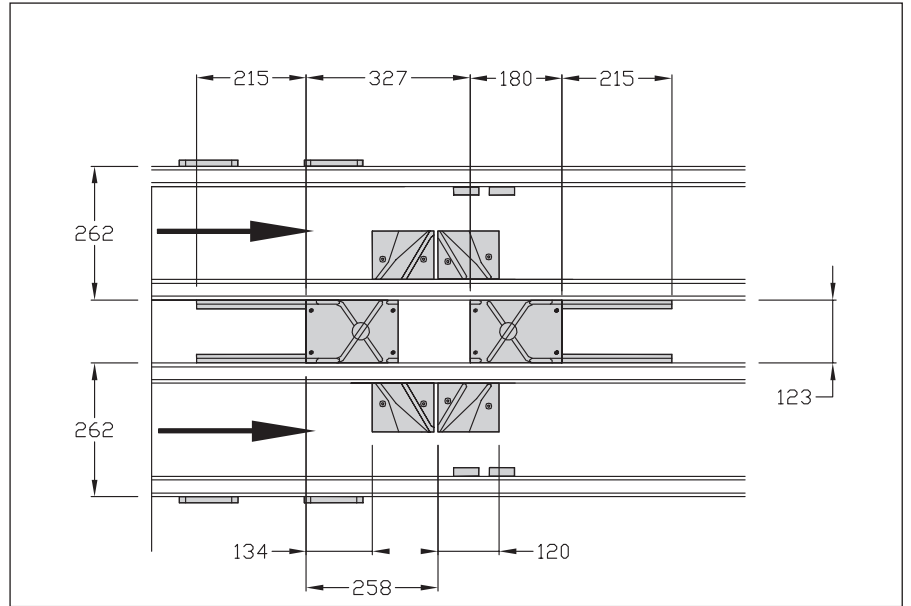

## Derivations Widths 200-300-400

### Technical data

Complete set including:

- ✘ 2 plates Al
- ✘ 2 nuts St M6
- ✘ 2 screws M6x20
- ✘ Body, levers, guides PA and screws and bolts
- ✘ 2 cylinders  $\varnothing$  20-10 (M5), detectable positions
- ✘ 1 protection Ac black



**Cams are not included (must be ordered separately).**

Weight: Derivation 200: 1,4 kg  
Derivation 300: 1,5 kg  
Derivation 400: 1,5 kg

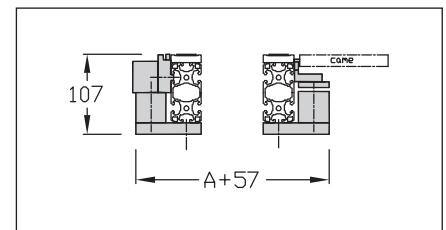
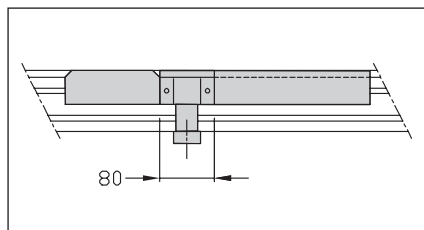
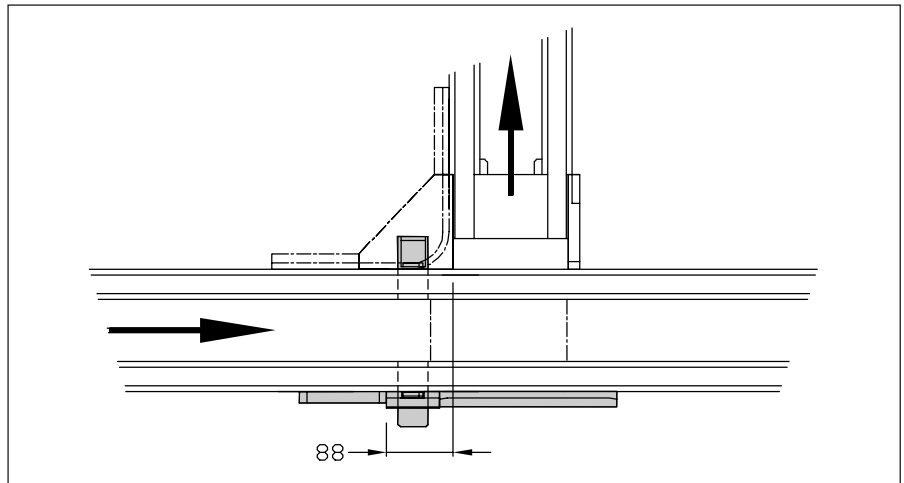

Designation / Dimensions	Order unit	Reference
<b>Derivation 200</b>	<b>1 set</b>	<b>120.07.000</b>
<b>Derivation 300</b>	<b>1 set</b>	<b>130.07.000</b>
<b>Derivation 400</b>	<b>1 set</b>	<b>140.07.000</b>



## Swivellings 90° Widths 200-300-400

### Technical data

Complete set including:

- ✘ Plates and lateral guide supports, PA black
- ✘ 3 cylinders ø 20-10 (M5)
- ✘ 1 stopper
- ✘ 2 brackets for shielded mounting sensor M12x100

A stopper located before the swivelling unit is generally necessary to avoid the arrival of another workpiece carrier during swivelling.



Minimum load on workpiece carrier:  
2 daN

Weight: Swivelling 90° 200: 3,8 kg  
Swivelling 90° 300: 5,8 kg  
Swivelling 90° 400: 6,9 kg

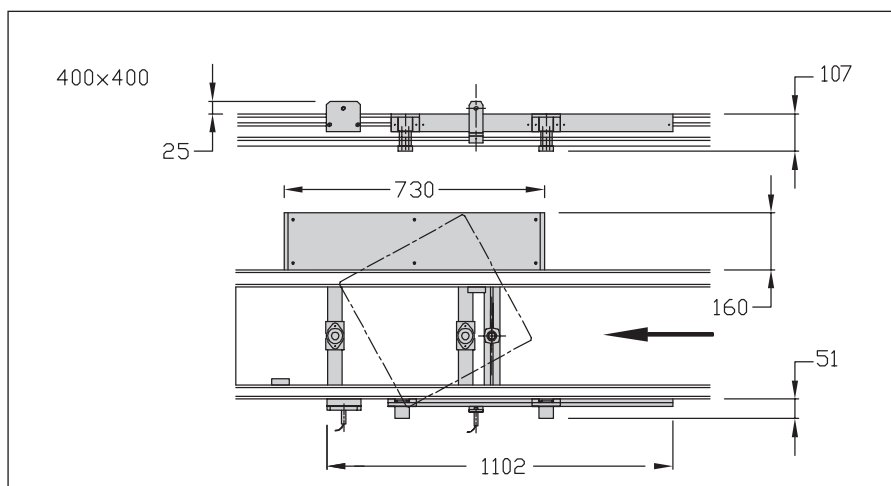
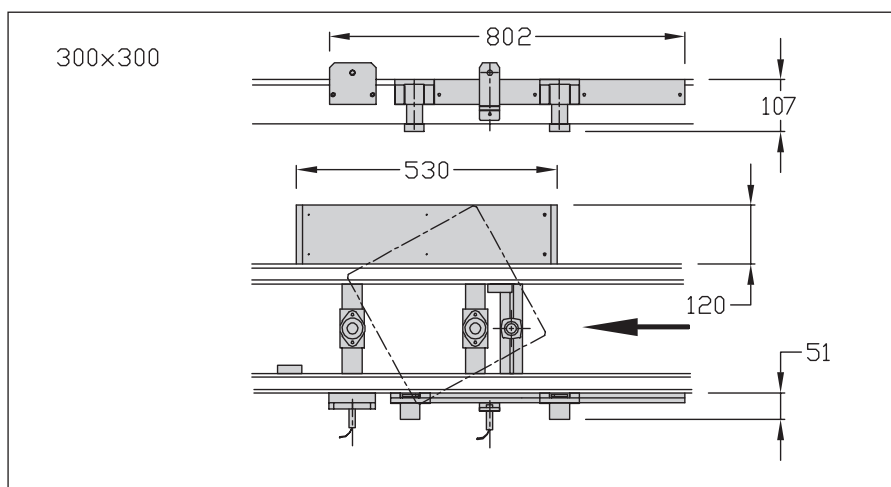
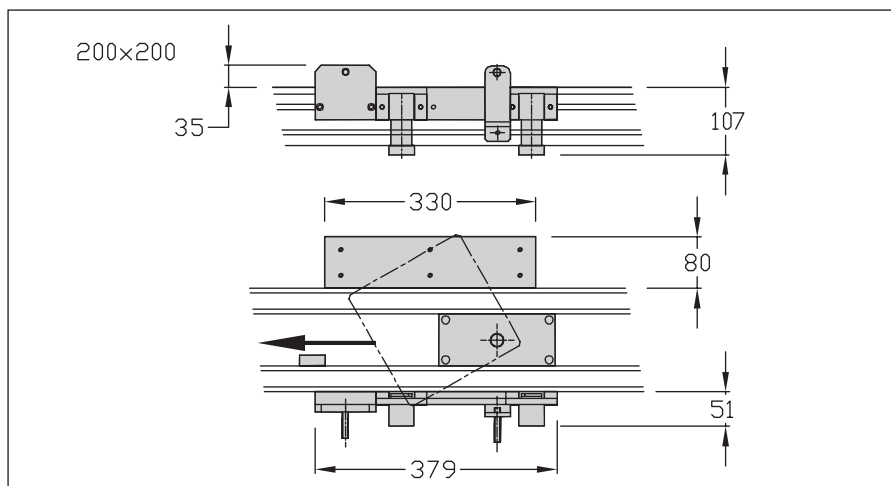

Designation / Dimensions	Order unit	Reference
Swivelling 90° 200	1 set	120.27.000
Swivelling 90° 300	1 set	130.27.000
Swivelling 90° 400	1 set	140.27.000

Specify (R) for spring stopper e.g. 130.27.000 (R)

# Swivellings 180° Widths 200-300-400

## Technical data

- ✘ Stopper
- ✘ Linear rotating cylinder
- ✘ Sensor bracket

A stopper located before the swivelling unit is generally necessary to avoid the arrival of another workpiece carrier during the swivelling.

 Flow rate controllers should be adapted.

Weight: Swivelling 180° 200: 5,6 kg  
Swivelling 180° 300: 6,7 kg  
Swivelling 180° 400: 7,6 kg

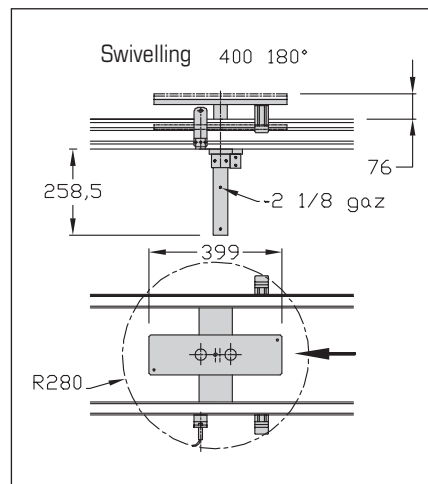
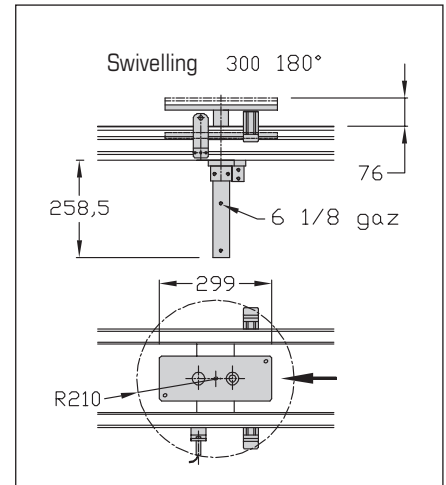
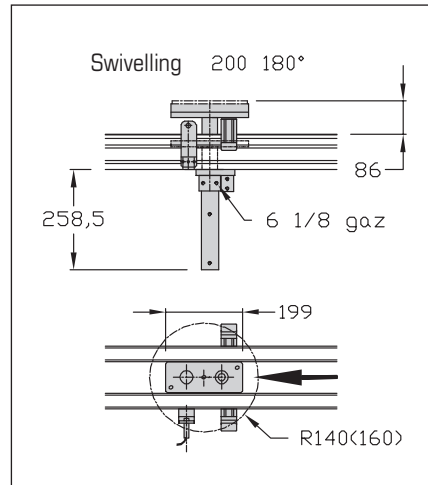

Designation / Dimensions	Order unit	Reference
<b>Swivelling 180° 200</b>	<b>1 set</b>	<b>120.28.000</b>
<b>Swivelling 180° 300</b>	<b>1 set</b>	<b>130.28.000</b>
<b>Swivelling 180° 400</b>	<b>1 set</b>	<b>140.28.000</b>
<b>Shock absorber kit</b>	<b>1 set</b>	<b>120.28.200</b>

Specify (R) for spring stopper e.g. 130.28.000 (R)

## Rotation damper kit

### APPLICATIONS

Allows dumping at the end of the stroke on a 180° return.

#### Technical data

**x** 2 dampers M8x100

To be mounted on 180° return, ref.:

120.28.000

130.28.000

140.28.000

Weight: 0,23 kg

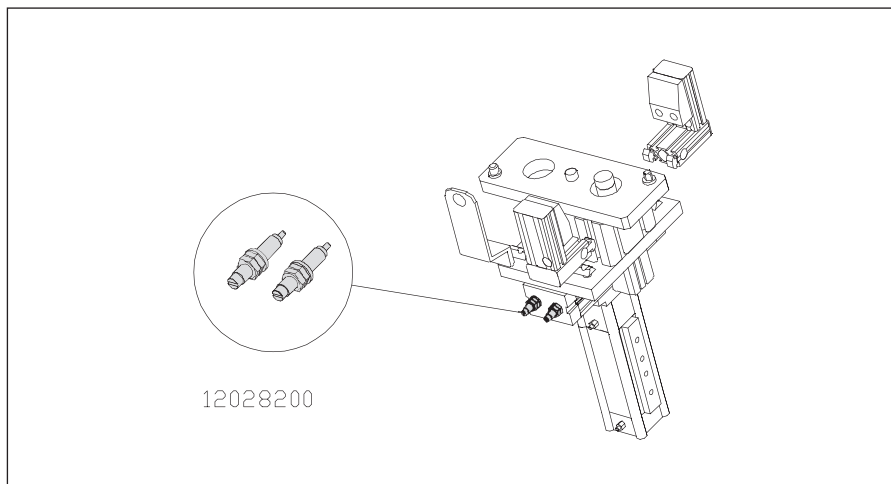

**Designation / Dimensions**

**Rotation damper kit**

**Order unit**

**1 set**

**Reference**

**120.28.200**

## Conveying unit stands

### APPLICATIONS

Support to fit conveying units on table or frame.  
With profile 40x40 and 80x40, it is compatible with full range of profiles and modular elements of **elcom**.

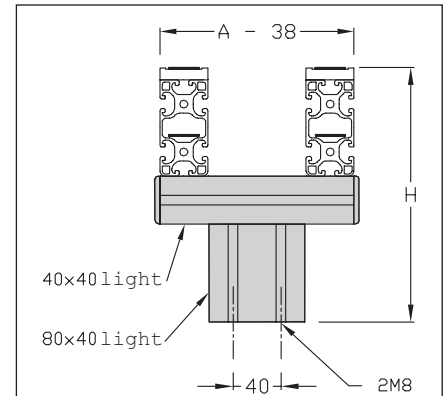

Designation / Dimensions	Order unit	Reference
Conveying unit stand 200	1 set	120.20.000
Conveying unit stand 300	1 set	130.20.000
Conveying unit stand 400	1 set	140.20.000

## Simple stands

### APPLICATIONS

Support for one conveying unit.  
With profile 40x40 and 80x40, it is compatible with full range of profiles and modular elements of **elcom**.

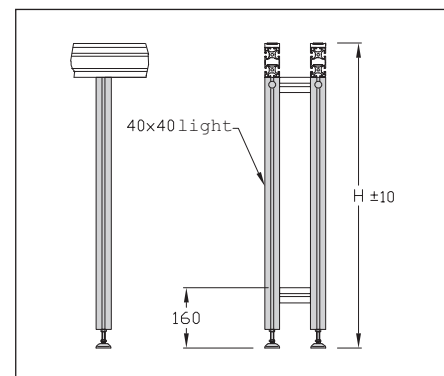

Designation / Dimensions	Order unit	Reference
Simple stand 200	1 set	120.12.000
Simple stand 300	1 set	130.12.000
Simple stand 400	1 set	140.12.000

## Double stands

### APPLICATIONS

Support for two parallel conveying units.  
With profile 40x40 and 80x40, they are compatible with full range of profiles and modular elements of **elcom**.

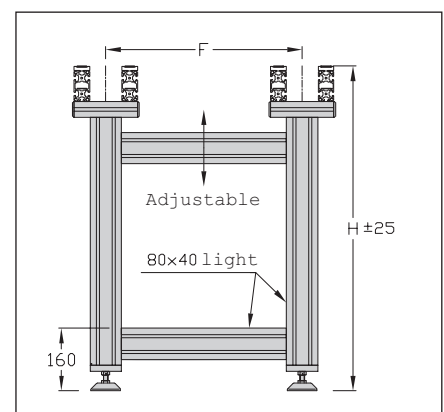

Designation / Dimensions	Order unit	Reference
Double stand 200	1 set	120.19.000
Double stand 300	1 set	130.19.000
Double stand 400	1 set	140.19.000

## Stoppers

### APPLICATIONS

Stopping workpiece carriers during processing requiring no accuracy. They are perfectly adapted for manual work stations.

Workpiece carriers are stopped to respect conveying priorities at the end of the derivation.

Stoppers can be supplied with a spring to make the stopper rod pop out in case of an emergency stop.

Supplied with sensor bracket for detection of workpiece carriers.



## Stopper 24 V



### APPLICATIONS

Stopping workpiece carriers during processing requiring no accuracy. They are perfectly adapted for manual work stations.

Workpiece carriers are stopped to respect conveying priorities at the end of the derivation.

Butée simple effet rappel par ressort, livrée avec guides latéraux, support détecteur de présence palette.

Supplied with sensor bracket for detection of workpiece carriers.

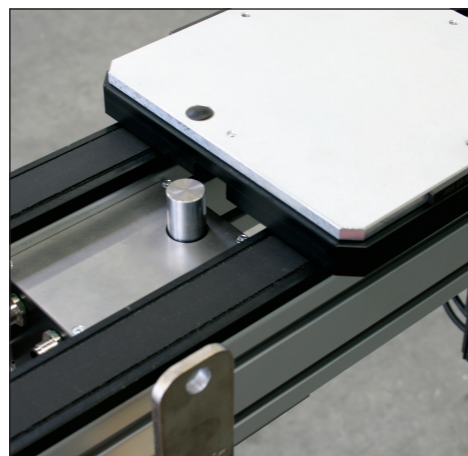

## Damped stoppers

### APPLICATIONS

They allow to reduce the shock of the workpiece carrier on the stoppers or on positioning unit stoppers.

Stopper rod moves in contact with the workpiece carrier and a shock absorber neutralizes the kinetic energy of workpiece carrier.

The stop position depends on the load on the workpiece carrier or the number of workpiece carriers.

The maximum load on a stopper for an optimum damping is 20 kg.

All stoppers have springs which enable to maintain stopper rod in high position in case of emergency stop.

Preferably use workpiece carriers with shock absorbers.



## Damped stopper, pneumatic

### APPLICATIONS

Stopping workpiece carriers during process requiring no accuracy. Perfectly adapted for manual operations.

Workpiece carriers are stopped to respect conveying priorities at the end of derivation.

The stopper 200, damped, pneumatic is used to reduce the shock between the workpiece carrier and the stopper thanks to the adjustable damped function.

The damped is adjusted in an optimum way for a workpiece carrier but can be different according to the weight of each workpiece carrier.

The sensor bracket is provided.

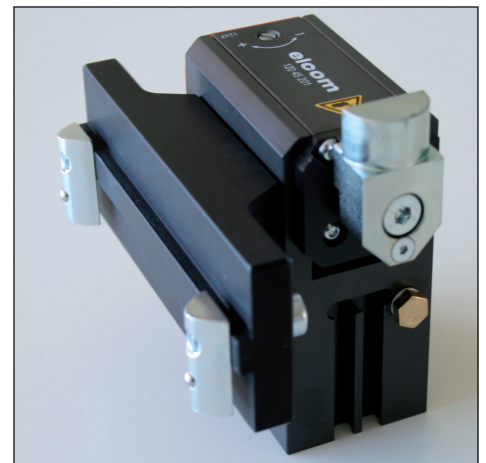

## Short stoppers

### APPLICATIONS

Thanks to the combination of small size and reduced height, the short stopper allows construction of ergonomic workstations along the line.

Reduced accumulated load.

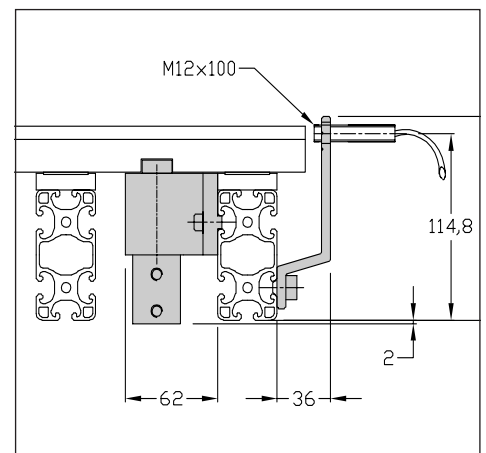



## Stoppers Widths 200-300-400

### Technical data

- ✗ Stopper rod (polyurethane coated)
- ✗ Complete set with double effect cylinder ø32 mm, detectable positions
- ✗ Bracket for shielded mounting sensor M12x100
- ✗ Detection range: 4 mm

Maximum load: 50 daN  
(in accumulation)



Flow rate controllers G 1/8 should be adapted

Weight: 200: 1,3 kg  
300: 1,7 kg  
400: 2 kg

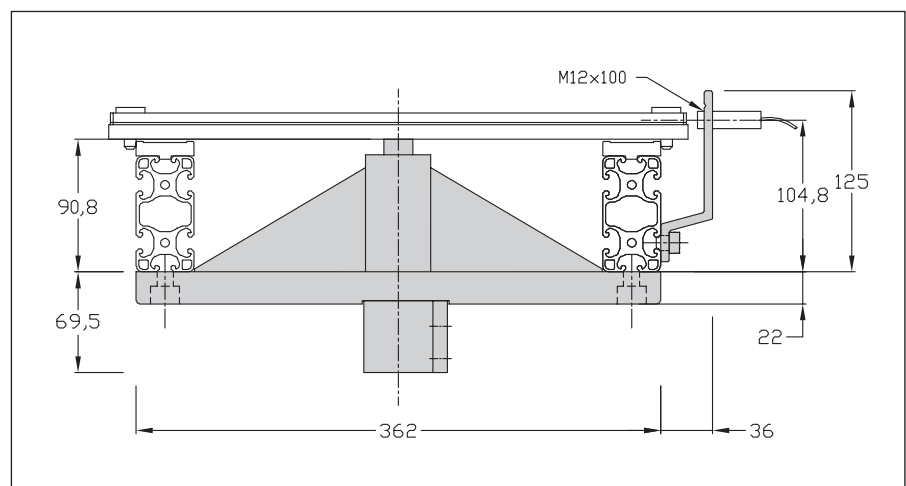
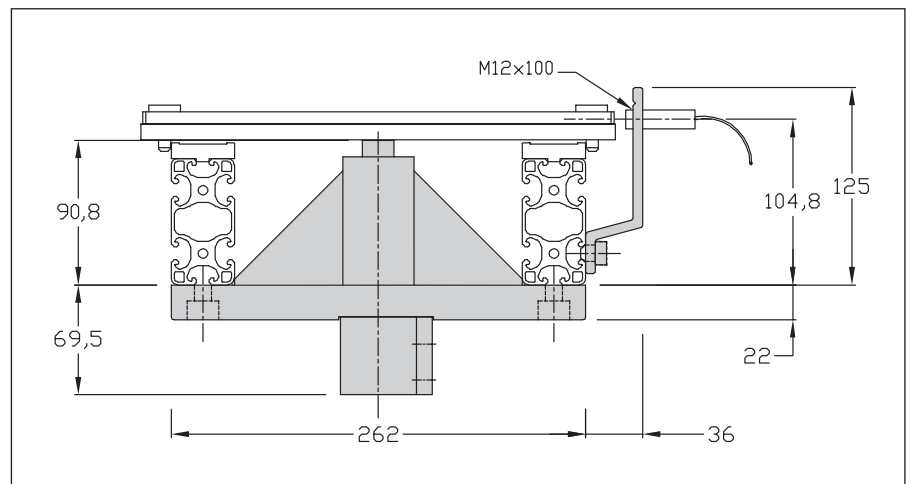
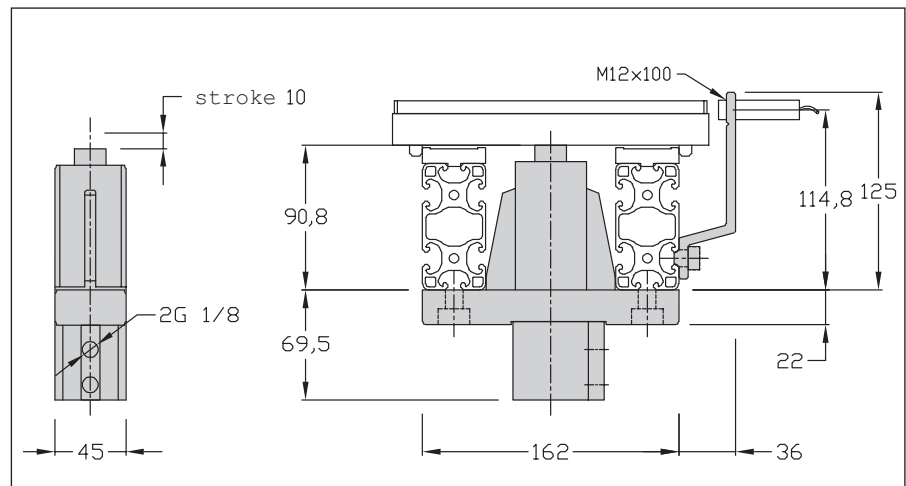

Designation / Dimensions	Order unit	Reference
<b>Stopper 200</b>	<b>1 pce</b>	<b>120.65.000</b>
<b>Stopper 300</b>	<b>1 pce</b>	<b>130.65.000</b>
<b>Stopper 400</b>	<b>1 pce</b>	<b>140.65.000</b>

Specify (R) for spring stopper e.g. 120.65.000 (R)

# Stopper 24 V Width 200

## Technical data

- ✗ Plate, stainless steel
- ✗ Body and stopper PA
- ✗ Nuts 8 St M6 + screws
- ✗ Hole for shielded sensor M12x100
- ✗ Detection range: 4 mm

Supply voltage of of the control box:

24 VDC +/- 15%

Power supply: 0.9 A maxi

Control voltage: 24 VDC +/- 10 %

Control current: 5 mA maxi

A Brushless gear motor controlled by a control box ensures the change in position.

Control module 24v output: automation, bus module, splitter,...

Standard connectors M12.

Maximum load: 50 daN  
(in accumulation)

Weight: 1.75 kg

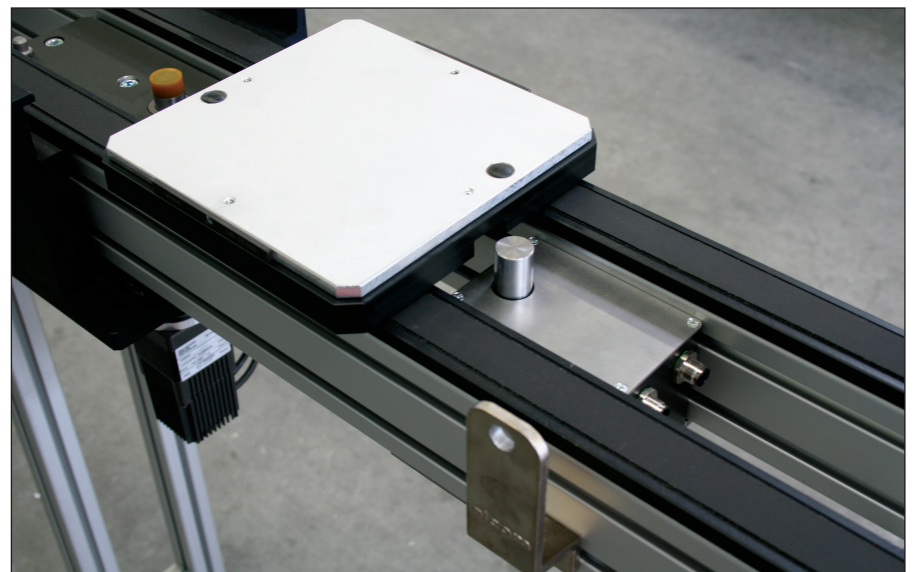
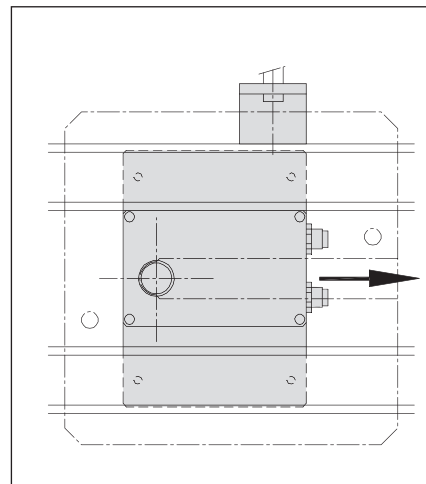
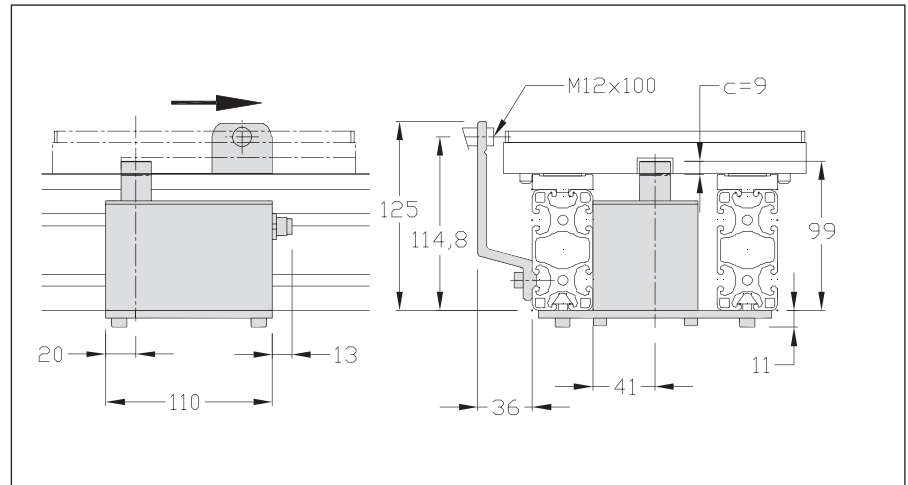

Designation / Dimensions	Order unit	Reference
Stopper 24 V 200	1 pce	120.65.000.E

## Damped stoppers Widths 200-300-400

### Technical data

- ✘ Stopper rod, steel
- ✘ Complete set with double effect cylinder  $\varnothing 32$ , detectable positions.
- ✘ Bracket for shielded mounting sensor M12x100.
- ✘ Detection range: 4 mm

Maximum load: 20 daN



Flow rate controllers G 1/8 should be adapted

Weight: 200: 1,4 kg  
300: 1,8 kg  
400: 2,1 kg

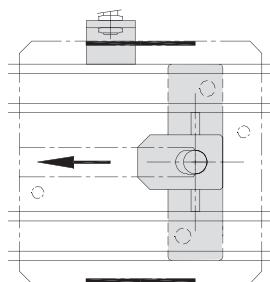
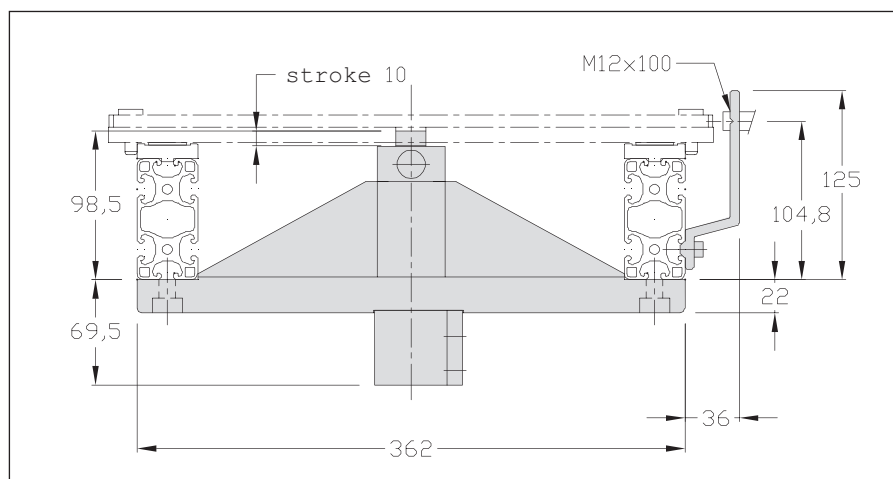
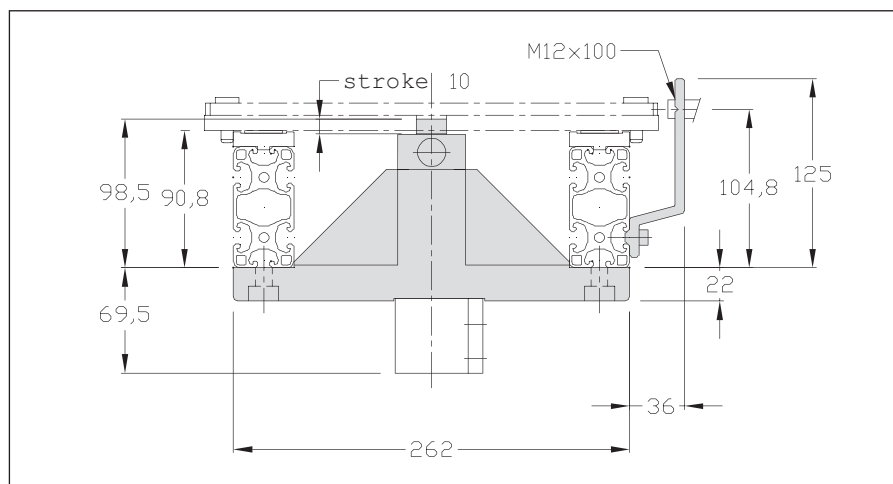
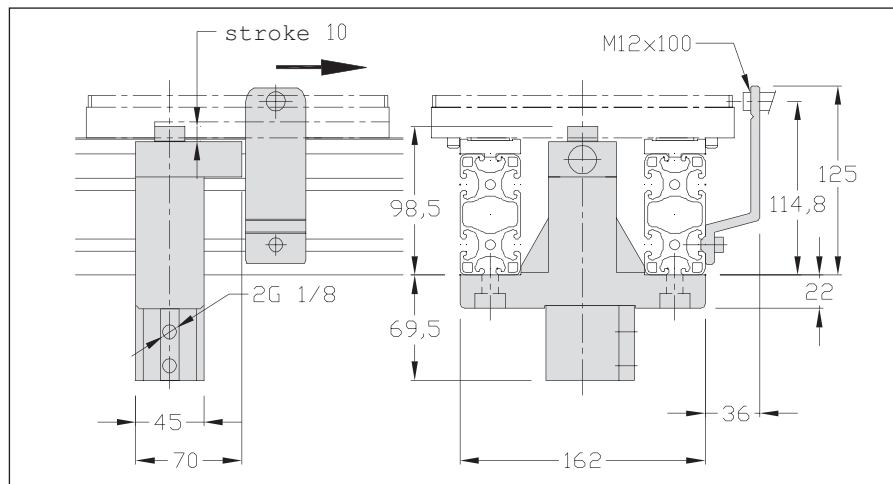

Designation / Dimensions	Order unit	Reference
Damped stopper 200	1 pce	120.65.000.RA
Damped stopper 300	1 pce	130.65.000.RA
Damped stopper 400	1 pce	140.65.000.RA

(R) for spring stopper-(A) for damped

## Damped stopper, pneumatic Width 200

### Technical data

- ✘ Stopper
- ✘ Stopper bracket
- ✘ Sensor bracket
- ✘ Screws and nuts

#### Maximum load:

9m/min	1,7-60 kg
15m/min	1,7-50 kg
19m/min.	1,7-43 kg

Air consumption: 0,11 l for a pressure of 6 bars.

Pressure on use: 4 to 8 bars.  
Connection M5 not included.

Restoring force: 115 N.

Longitudinal damping stroke: 23 mm.

Weight: 0,95 kg

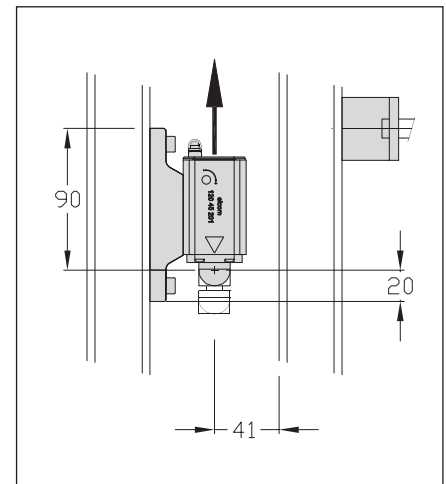
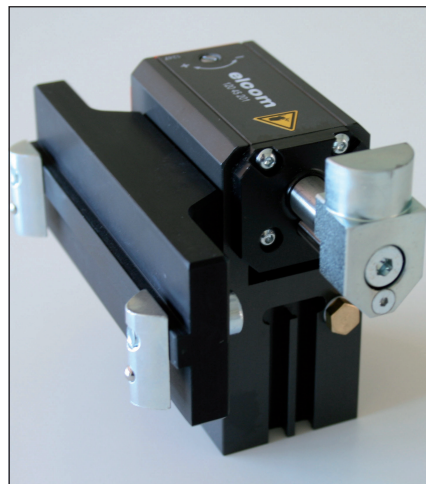
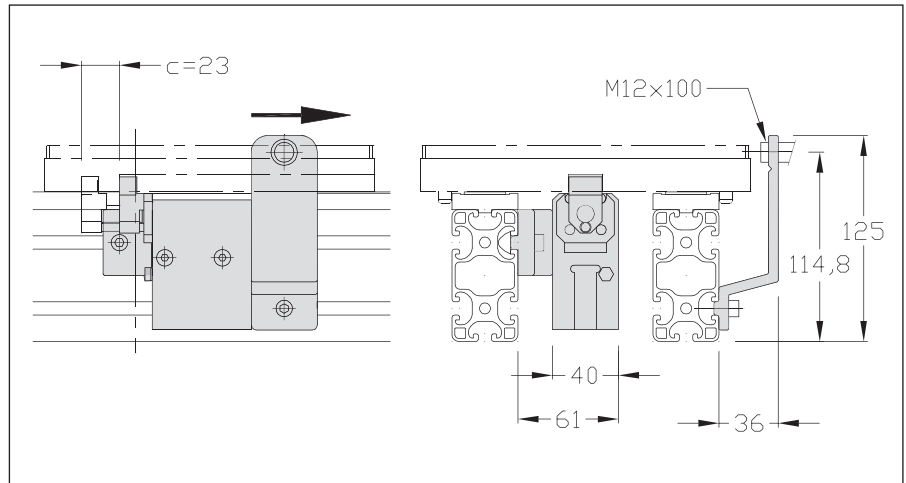

TLM 2000

Designation / Dimensions	Order unit	Reference
Damped stopper, pneumatic 200	1 pce	120.45.000 RAP

## Short stoppers Widths 200-300-400

### APPLICATIONS

#### Technical data

- ✘ Stopper rod (polyurethane coated)
- ✘ Complete set with double effect cylinder  
ø 20 mm, detectable positions.
- ✘ Bracket for shielded mounting sensor  
M12x100.
- ✘ Detection range: 4 mm

Stoppers 300-400:

- ✘ 1 profile Al 80x40 light
- ✘ 2 universal fastenings B

Maximum load: 15 daN

(in accumulation)



Flow rate controllers G 1/8 should be adapted

Weight: 200: 0,9 kg  
300: 1,4 kg  
400: 1,8 kg

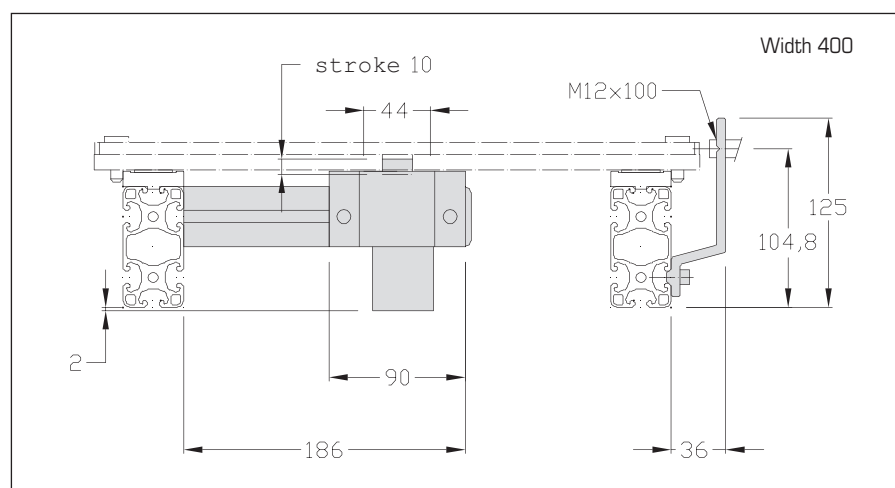
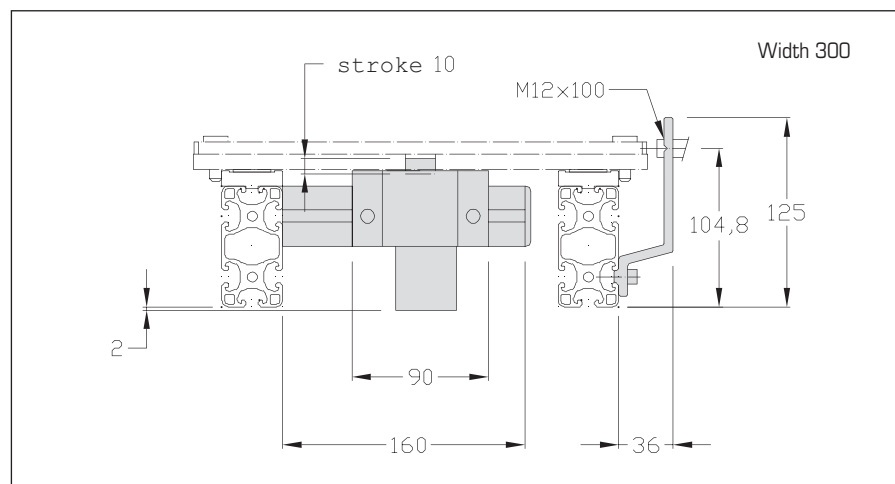
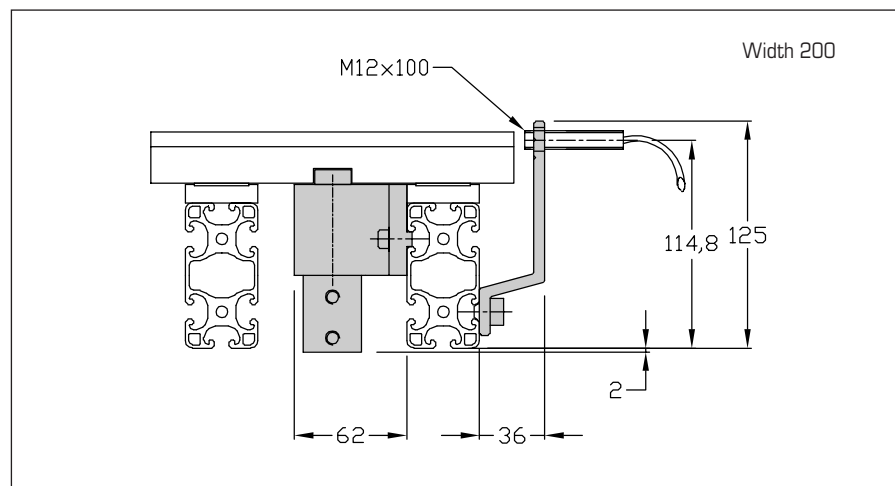

Designation / Dimensions	Order unit	Reference
Short stopper 200	1 pce	120.32.000
Short stopper 300	1 pce	130.32.000
Short stopper 400	1 pce	140.32.000

Specify (R) for spring stopper e.g. 120.32.000 (R)

# Brush unit

## APPLICATIONS

Allows the cleaning of the transfer units of conveying belts.

The brushes sweep any potential deposits on the belts and avoid the accumulation of foreign materials in mechanical parts.

Two articulated arms with fixed brushes installed in the belt conveying direction allow continuous mechanical cleaning of the conveyor belts.

The arms retracts automatically during the traffic of workpiece carriers.

### Technical data

Complete set including:

- ✘ 2 brushes
- ✘ 2 brackets
- ✘ Screws and nuts

Weight: 0,86 kg

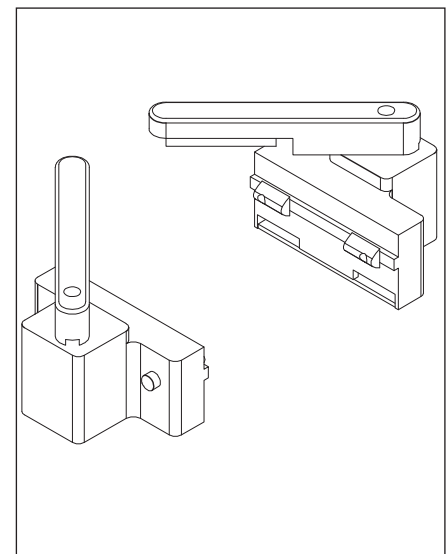
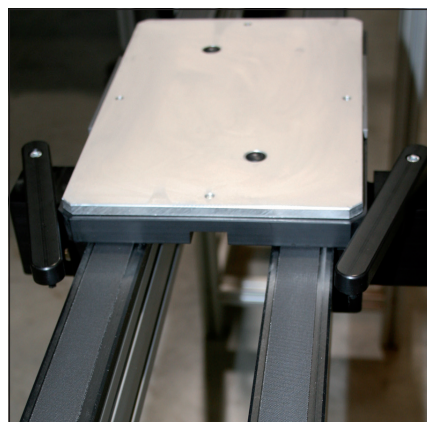
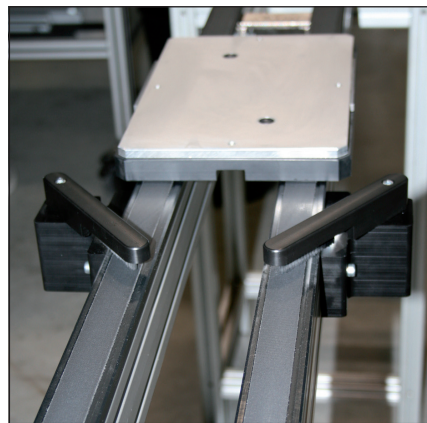
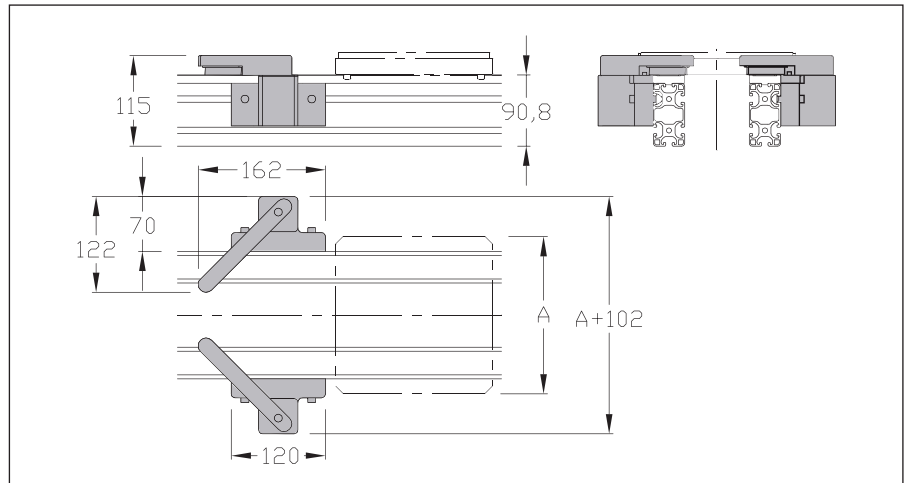

Designation / Dimensions	Order unit	Reference
Brush unit	1 set	120.49.000



## Positioning units

Stopping and positioning workpiece carriers for operations requiring accuracy. The workpiece carrier is stopped, then lifted off the belts and positioned by a pin and a locating. In case of heavy shocks, it is possible to use positioning units with damped stopper.

### Positioning unit 24 V



The stopper of workpiece carriers is positioned by the vertical movement (unnecessary stopper control).

A Brushless gear motor ensures the control of the stopper and the positioning unit.

Irreversible system.



### Low positioning units

The positioning unit is directly fitted on the conveying units.

Damped low positioning units:

An upstream stopper is required.

A cam repositions the workpiece carrier when the positioning unit is rising.

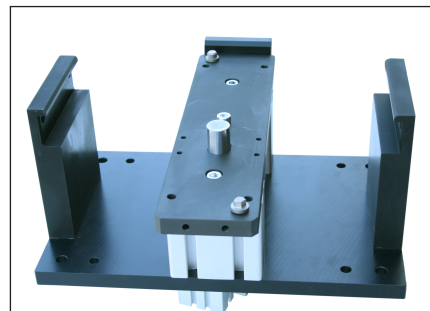

### Positioning units for station

They are fixed to a table or a frame to ensure accuracy of the other surrounding elements.

Damped positioning units for station:

An upstream stopper is required.

A cam repositions the workpiece carrier when the positioning unit is rising.

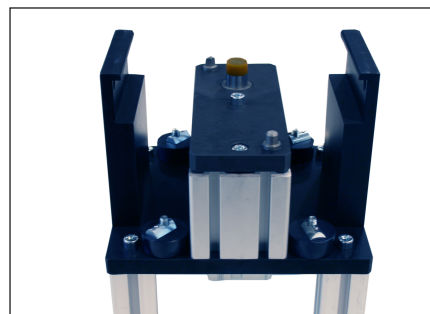

### Heavy positioning units

For operations requiring accuracy and involving important strain (up to 1500 daN) at the center of workpiece carrier.

The positioning unit must be fixed on a frame capable of supporting the strain applied.

Damped heavy positioning units:

An upstream stopper is required.

A cam repositions the workpiece carrier when the positioning unit is rising.

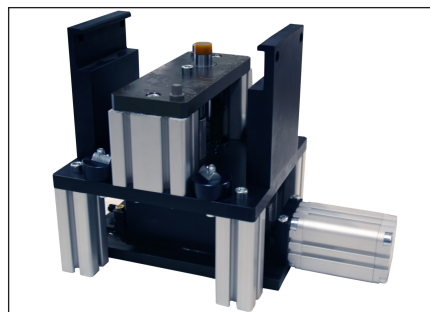

## Lift positioning units

They stop and position workpiece carriers at a significant height above the conveyor.  
The workpiece carrier is stopped, then elevated to a specific height, while being held by two centering pieces.

Damped lift positioning units:

An upstream stopper is required.

A cam repositions the workpiece carrier when the positioning unit is rising.

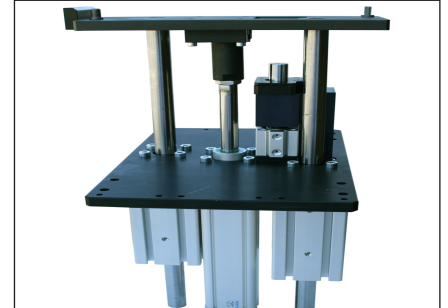

## Bridge positioning units

The bridge positioning units allow to rise a workpiece carrier in a station and to another workpiece carrier can flow below.

Particularly suitable at the checkpoint.

Positioning accuracy +/- 1 mm.

A refocusing of workpiece carrier is required for operations which need an important accuracy.

Damped bridge positioning units. An upstream stopper is required.



## Press positioning units

Support significant strain (5000 daN) on the surface between the two belts.

The positioning unit must be fixed on a frame capable of supporting the strain applied.

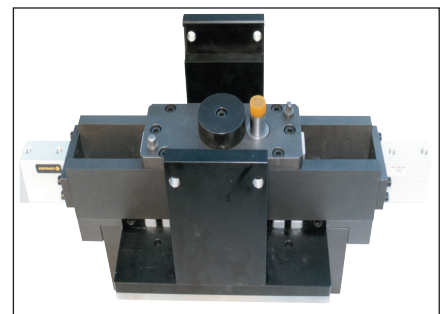

## Multi-positioning units

They allow two accurate positionings of the workpiece carrier at the same station.

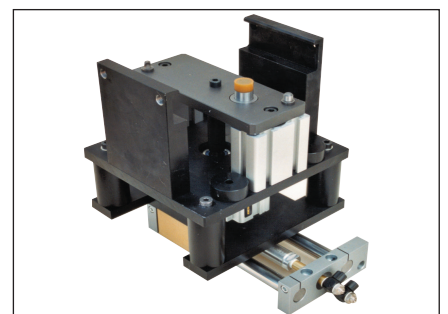

## Positioning units Widths 200-300-400

### Technical data

Complete set including:

- x** Stopper  
1 double effect cylinder  $\varnothing$  32,  
detectable positions
- x** Positioning unit  
1 double effect cylinder  $\varnothing$  50,  
detectable positions
- x** Holes for shielding mounting sensors  
M12x100
- x** Detection range: 4 mm
- x** Fastening parts



4 flow rate controllers G 1/8  
should be adapted

Maximum vertical strain: 100 daN for a  
pressure of 6 bars at the center of  
workpiece carrier

Repeatability: +/- 0,03 mm

Weight: 200: 8,7 kg  
300: 10,5 kg  
400: 12,2 kg

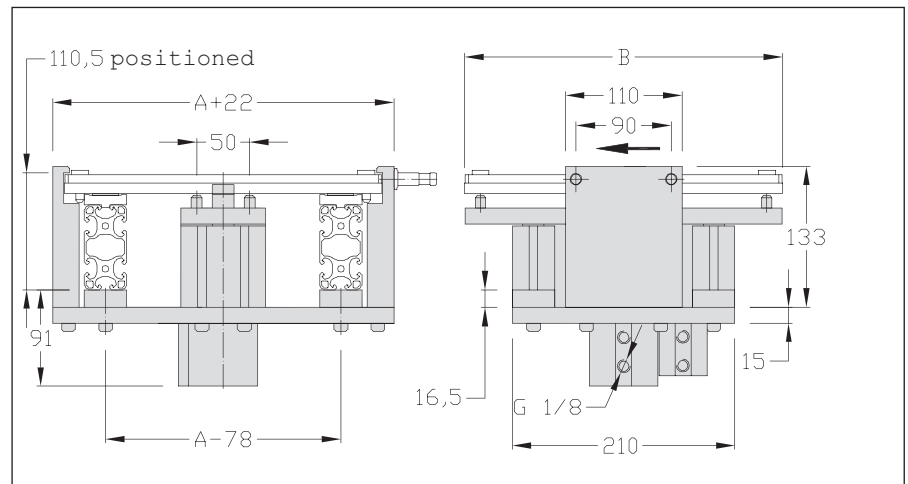
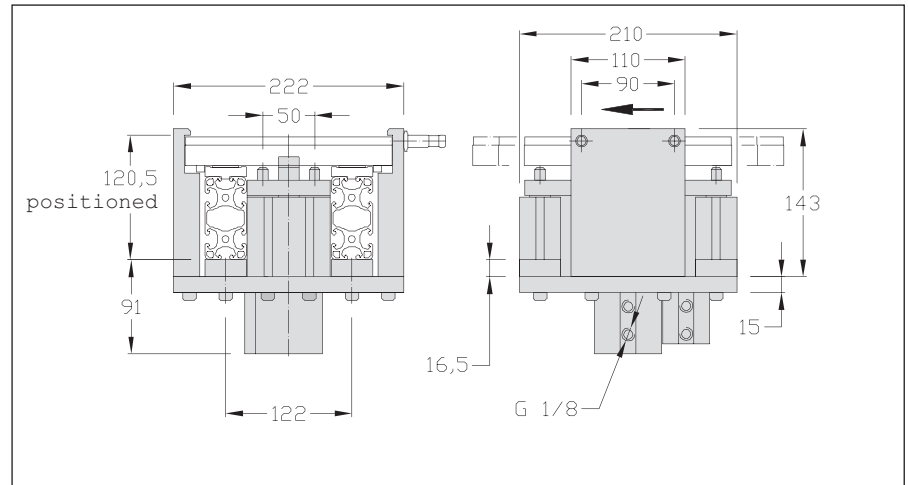

A = workpiece carrier width  
B = workpiece carrier length

Designation / Dimensions	Order unit	Reference
Positioning unit 200	1 pce	120.64.000
Positioning unit 300	1 pce	130.64.000
Positioning unit 300x400	1 pce	134.64.000
Positioning unit 400	1 pce	140.64.000

Specify (R) for spring stopper e.g. 120.64.000 (R)

# Positioning unit 24 V Automatic stopper Width 200

## Technical data

Complete set including:

- ✘ 1 gear motor 24 V
- ✘ Vertical movement provided by an irreversible screw-nut system
- ✘ Vertical position controlled by encoder
- ✘ Housing for shielded mounting sensors M12x100
- ✘ Detection range: 4 mm
- ✘ Fastening parts

Maximum vertical strain: 100 daN.

Repeatability: +/- 0.03 mm

Motor supply voltage: 24 VDC

Motor supply current: 5,2 A

Control voltage: 24 VDC

Control current: 10 mA

5 positioning input status

4 output status

Weight: 8,5 kg

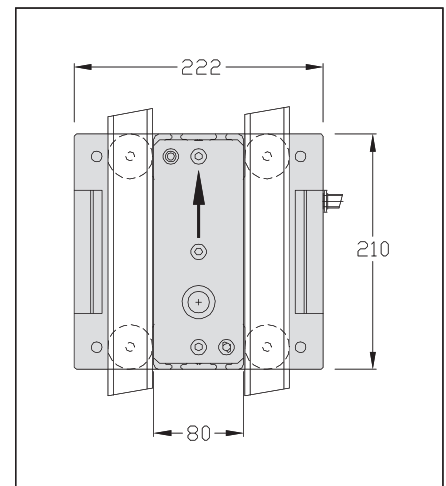
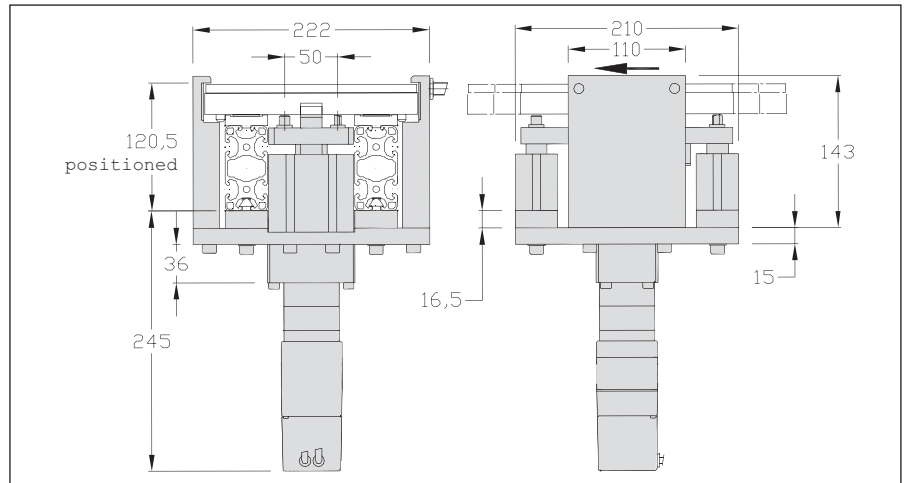

TLM 2000

Designation / Dimensions	Order unit	Reference
Positioning unit 24 V 200 Automatic stopper	1 pce	120.64.000.E

## Damped positioning units Widths 200-300-400

### Technical data

Complete set including:

- x** Stopper  
1 double effect cylinder  $\varnothing 32$ , detectable positions
- x** Positioning unit  
1 double effect cylinder  $\varnothing 50$ , detectable positions
- x** Holes for shielding mounting sensors  
M12x100
- x** Detection range: 4 mm
- x** 4 supports in profile 8 40x40
- x** Fastening parts



Flow rate controllers G 1/8 should be adapted

Maximum vertical strain: 100 daN for a pressure of 6 bars at the center of workpiece carrier.

Repeatability: +/- 0,03 mm

Weight: 200: 10,2 kg  
300: 11,2 kg  
400: 13 kg

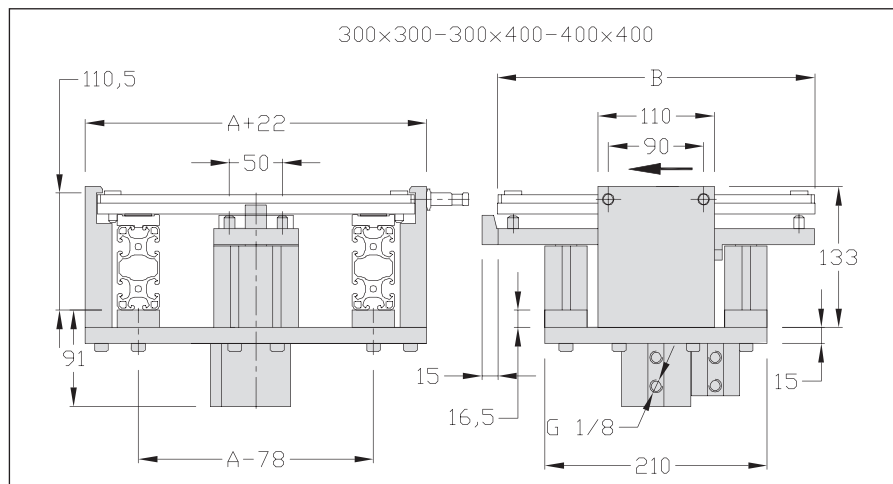
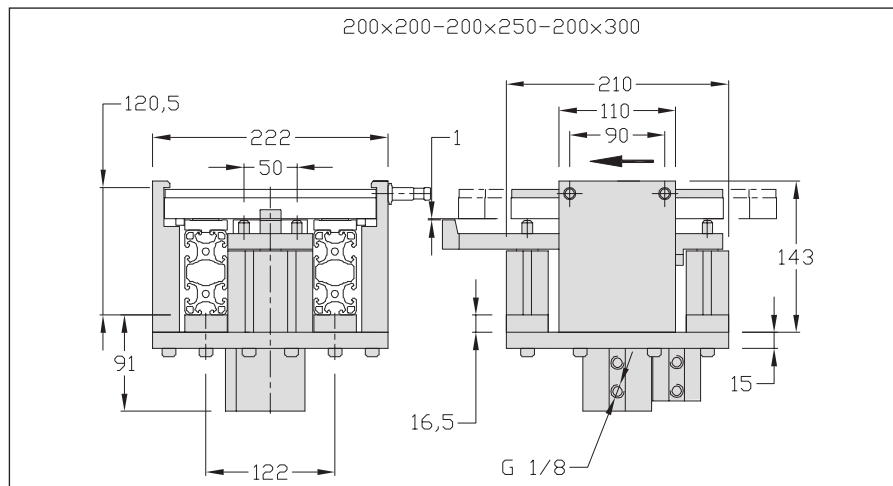

A = workpiece carrier width  
B = workpiece carrier length

Designation / Dimensions	Order unit	Reference
Damped positioning unit 200	1 pce	120.64.000.RA
Damped positioning unit 200x250	1 pce	125.64.000.RA
Damped positioning unit 200x300	1 pce	123.64.000.RA
Damped positioning unit 300	1 pce	130.64.000.RA
Damped positioning unit 300x400	1 pce	134.64.000.RA
Damped positioning unit 400	1 pce	140.64.000.RA

# Positioning units for station Widths 200-300-400

## Technical data

Complete set including:

- ✘ Stopper  
1 double effect cylinder  $\varnothing 32$ ,  
detectable positions
- ✘ Positioning unit  
1 double effect cylinder  $\varnothing 50$ ,  
detectable positions
- ✘ Holes for shielding mounting sensors  
M12x100
- ✘ Detection range: 4 mm
- ✘ 4 supports in profile 8 40x40
- ✘ Fastening parts

 4 flow rate controllers G 1/8  
should be adapted

Maximum vertical strain: 100 daN for a  
pressure of 6 bars at the center of workpiece  
carrier

Repeatability: +/- 0,03 mm

Weight: 200: 8,7 kg  
300: 10,5 kg  
400: 12,2 kg

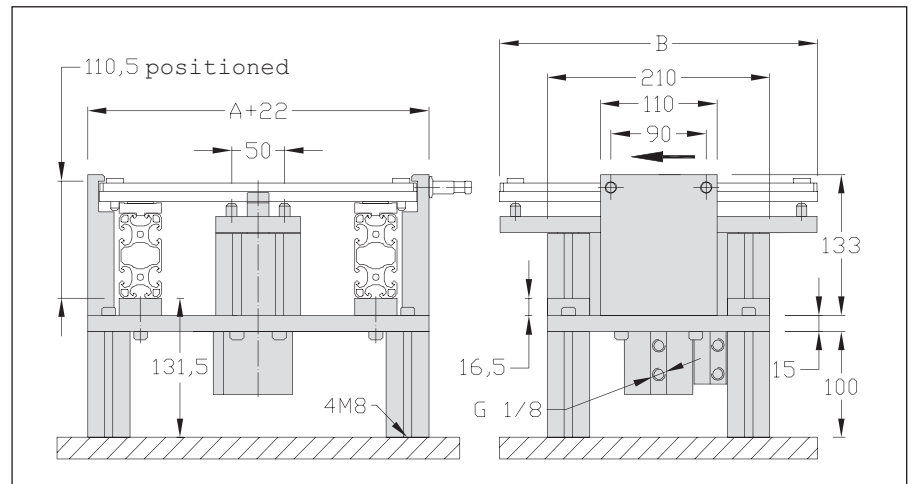
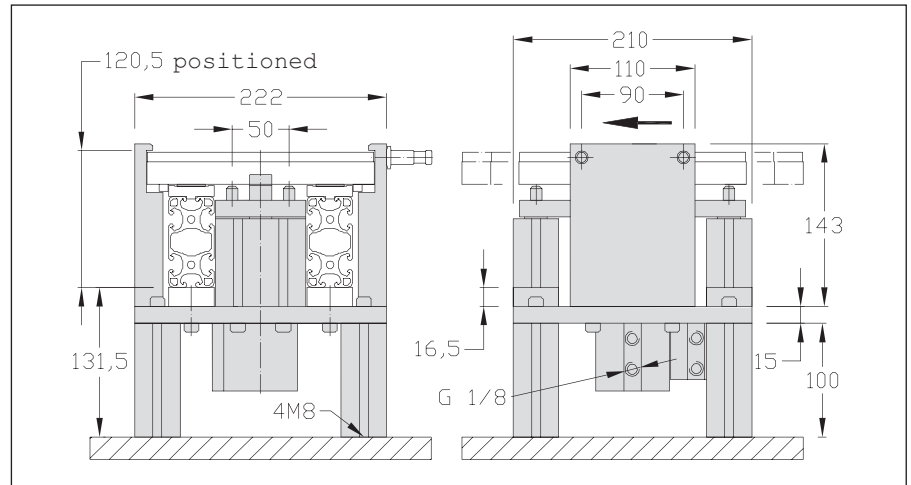

A = workpiece carrier width  
B = workpiece carrier length

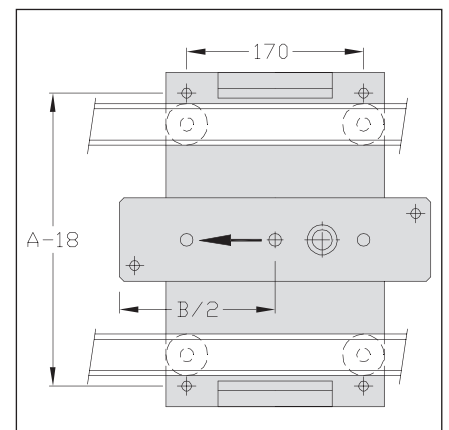

Designation / Dimensions	Order unit	Reference
Positioning unit for station 200	1 pce	120.69.000
Positioning unit for station 300	1 pce	130.69.000
Positioning unit for station 300x400	1 pce	134.69.000
Positioning unit for station 400	1 pce	140.69.000

Specify (R) for spring stopper e.g. 120.69.000 (R)



## Damped positioning units for station Widths 200-300-400

### Technical data

Complete set including:

- x** Stopper  
1 double effect cylinder  $\varnothing 32$ , detectable positions
- x** Positioning unit  
1 double effect cylinder  $\varnothing 50$ , detectable positions
- x** Holes for shielding mounting sensors  
M12x100
- x** Detection range: 4 mm
- x** 4 supports in profile 8 40x40
- x** Fastening parts



Flow rate controllers G 1/8 should be adapted

Maximum vertical strain: 100 daN for a pressure of 6 bars at the center of workpiece carrier.

Repeatability: +/- 0,03 mm

Weight: 200: 10,2 kg  
300: 11,2 kg  
400: 13 kg

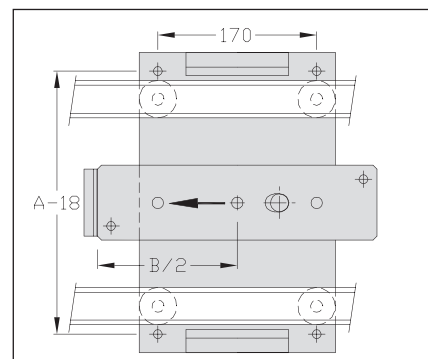
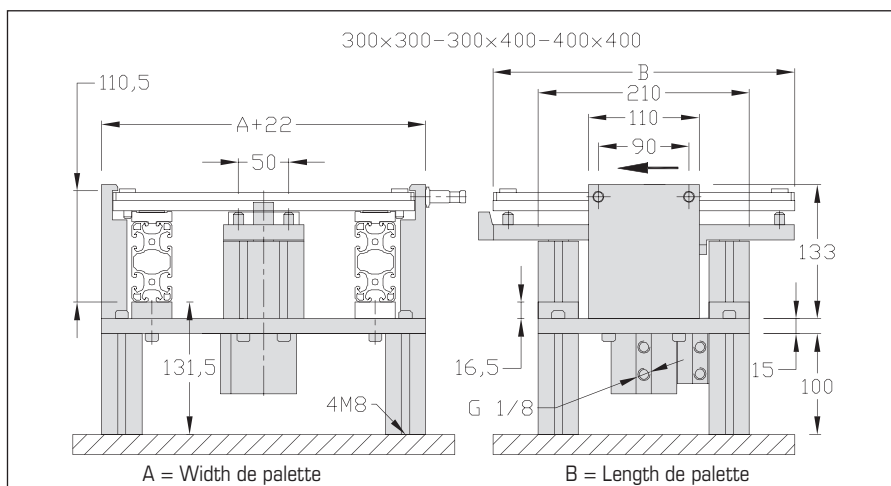
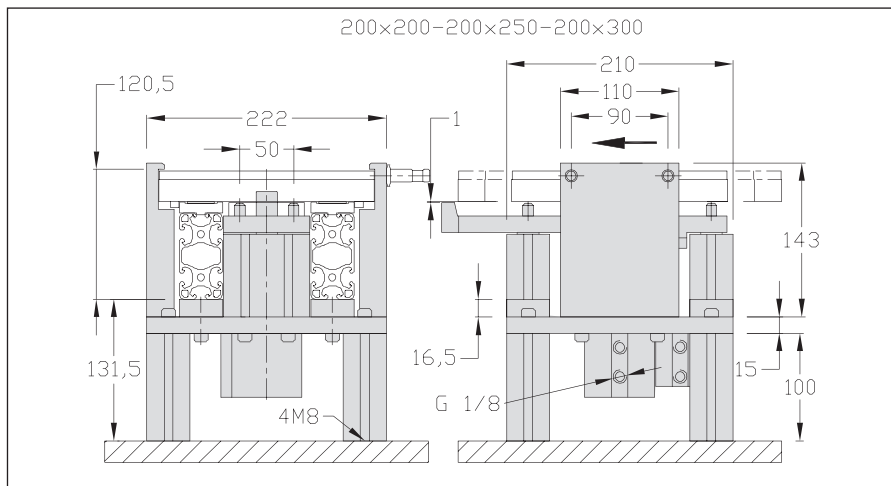

Designation / Dimensions	Order unit	Reference
Damped positioning unit for station 200	1 pce	120.69.000 RA
Damped positioning unit for station 200x250	1 pce	125.69.000 RA
Damped positioning unit for station 200x300	1 pce	123.69.000 RA
Damped positioning unit for station 300	1 pce	130.69.000 RA
Damped positioning unit for station 300x400	1 pce	134.69.000 RA
Damped positioning unit for station 400	1 pce	140.69.000 RA

## Dead man option, positioning units Widths 200-300-400

This option is available for all positioning units and positioning units for station widths 200 - 300 - 400.

Pneumatic clamping element for shaft  $\varnothing 25$ .

Locking by springs.

Retaining force: 750 N

Useful pressure range: 6 bars.

Weight: 1.3 kg

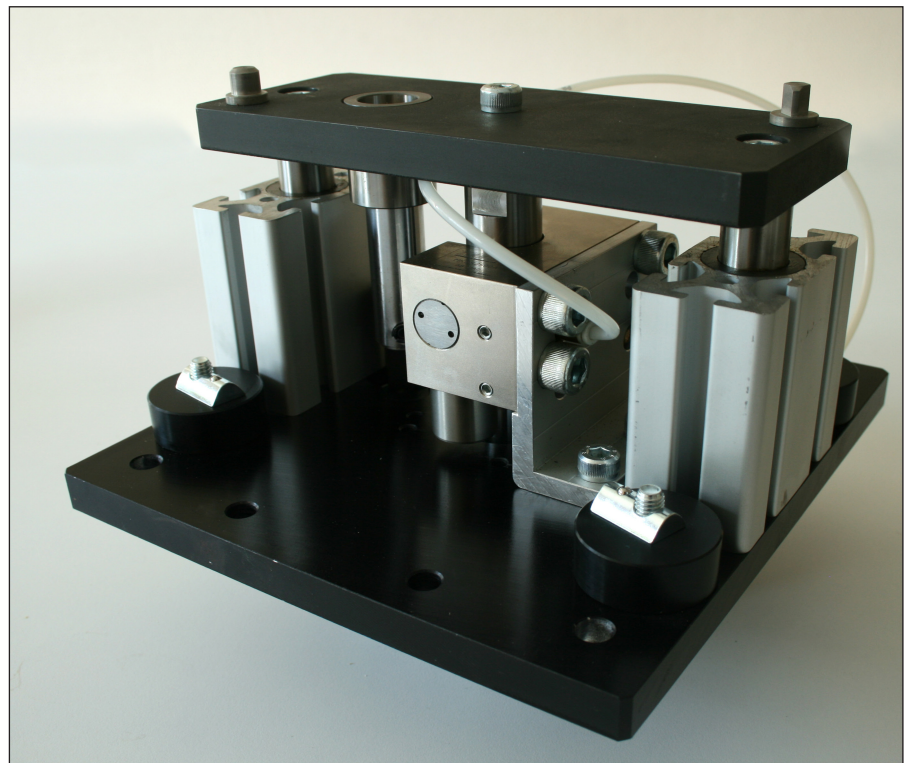
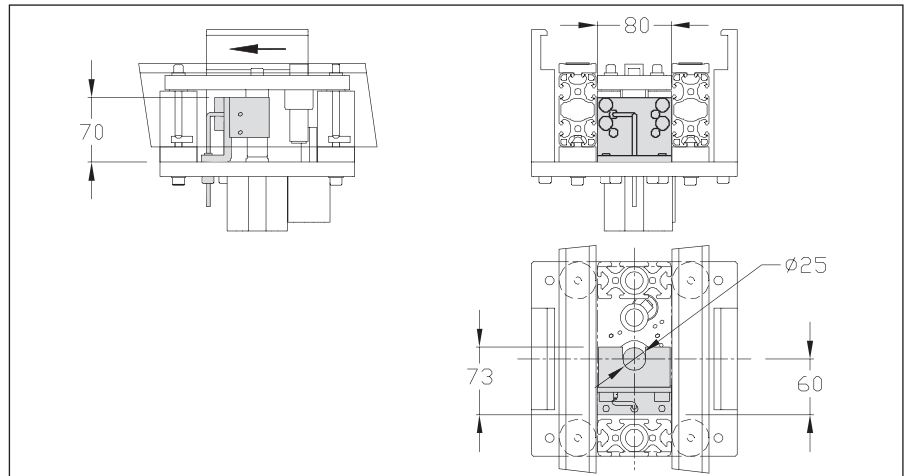

Designation / Dimensions	Unit order	Reference
Dead man option, positioning units 200 - 300 - 400	1 pce	120.74.000

## Heavy positioning units Widths 200-300-400

### Technical data

Complete set including:

- ✘ Stopper
- ✘ Positioning unit
- ✘ 2 pneumatic cylinders, detectable positions
- ✘ Spacers profile 40x40
- ✘ Fastening parts
- ✘ Holes for shielding mounting sensors M12x100
- ✘ Detection range: 4 mm



Flow rate controllers G 1/8 should be adapted

Maximum vertical strain: 1500 daN at the center of workpiece carrier (60x60 mm).

Repeatability: +/- 0,03 mm

Weight: 200: 18,3 kg  
300: 19,6 kg  
400: 21,8 kg

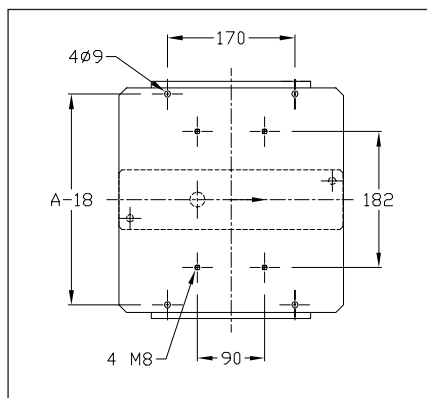
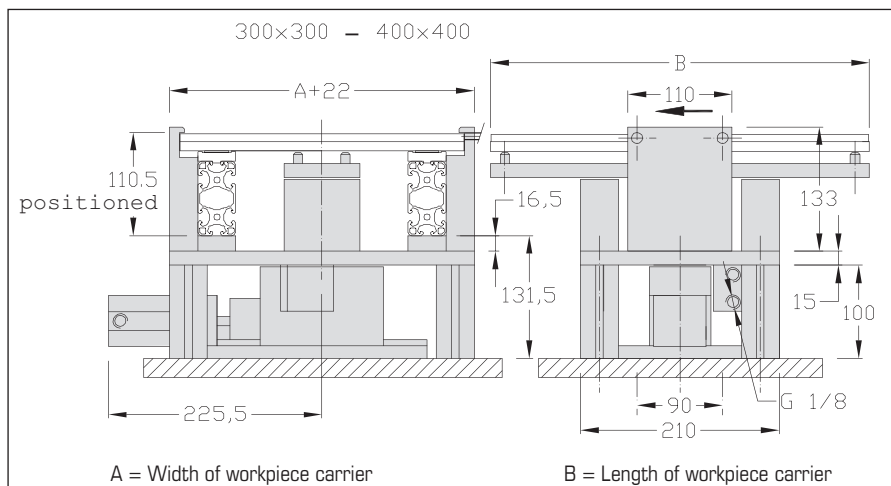
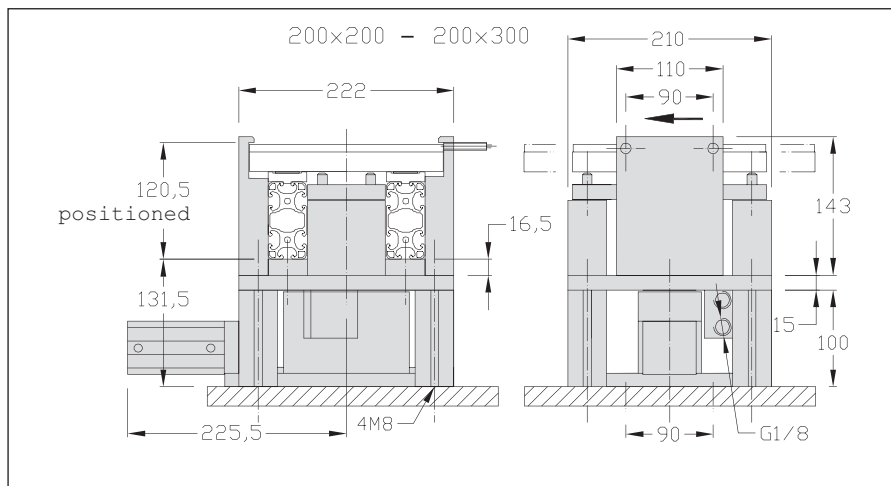

machining

Designation / Dimensions	Order unit	Reference
Heavy positioning unit 200	1 pce	120.68.000
Heavy positioning unit 300	1 pce	130.68.000
Heavy positioning unit 300x400	1 pce	134.68.000
Heavy positioning unit 400	1 pce	140.68.000

# Damped heavy positioning units Widths 200-300-400

## Technical data

Complete set including:

- ✗ Stopper
- ✗ Positioning unit
- ✗ 2 pneumatic cylinders, detectable positions
- ✗ Spacers profile 8 40x40
- ✗ Fastening parts
- ✗ Holes for shielding mounting sensors M12x100
- ✗ Detection range: 4 mm

 Flow rate controllers G 1/8 should be adapted

Maximum vertical strain: 1500 daN at the center of workpiece carrier (60x60mm)

Repeatability: +/- 0,03 mm

Weight: 200: 18,3 kg  
300: 19,6 kg  
400: 21,8 kg

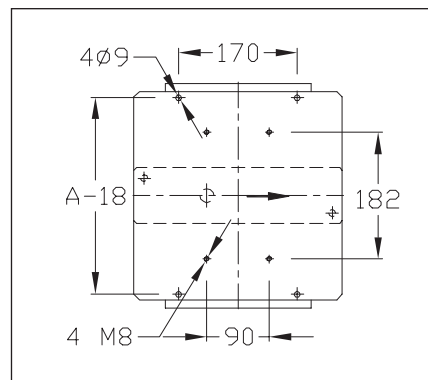
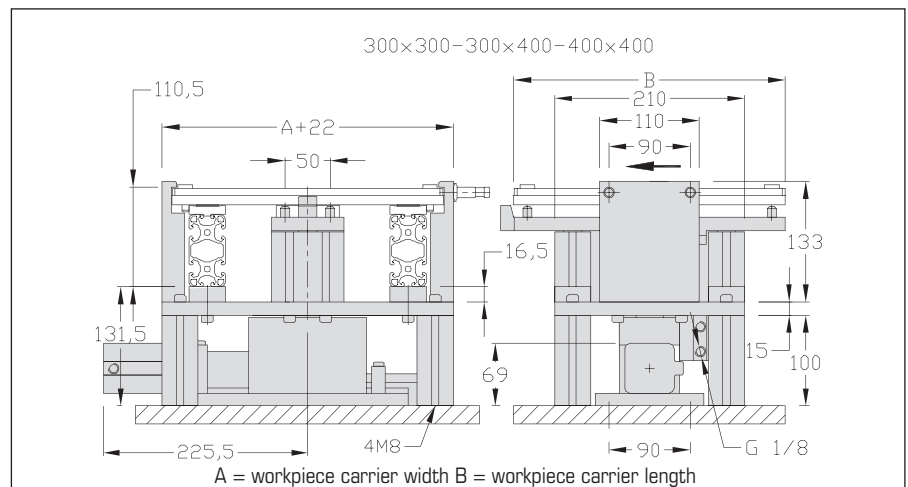
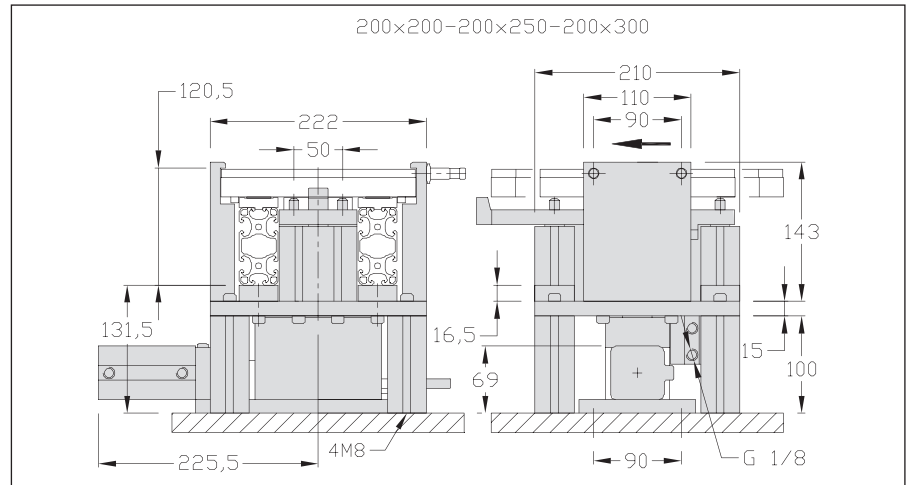

machining

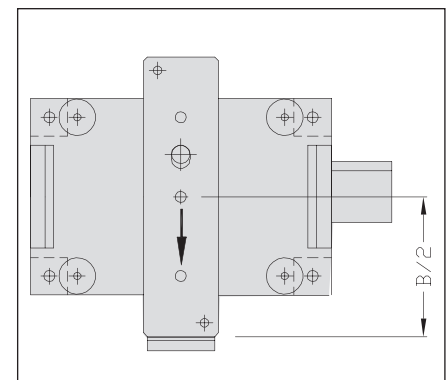

Designation / Dimensions	Order unit	Reference
Damped heavy positioning unit 200	1 pce	120.68.000 RA
Damped heavy positioning unit 200x250	1 pce	125.68.000 RA
Damped heavy positioning unit 200x300	1 pce	123.68.000 RA
Damped heavy positioning unit 300	1 pce	130.68.000 RA
Damped heavy positioning unit 300x400	1 pce	134.68.000 RA
Damped heavy positioning unit 400	1 pce	140.68.000 RA

## Lift positioning units Widths 200-300-400

### Technical data

Complete set including:

- x** Stopper
  - 1 double effect cylinder  $\varnothing$  32, detectable positions
- x** Positioning unit
  - 1 double effect cylinder  $\varnothing$  50, detectable positions
- x** Ball bearing guide bush  $\varnothing$  25
- x** Fastening parts
- x** 1 bracket for shielded mounting sensor M12x10
- x** Detection range: 4 mm



Flow rate controllers G 1/8 should be adapted

A stopper located before the lift unit is generally necessary to avoid the arrival of another workpiece carrier during lifting.

Cylinder strokes available:

50-80-100-125-160 -200-250-300-320-400 mm

Maximum vertical strain: 100 daN at the center of workpiece carrier

Repeatability: +/- 0,06 mm

Weight: 200: 10,6 kg

300: 19,6 kg

400: 22,5 kg

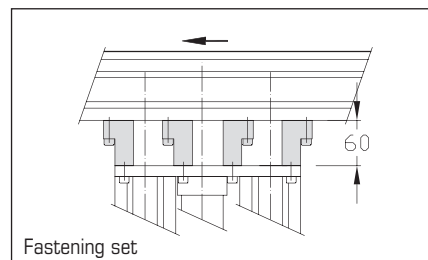
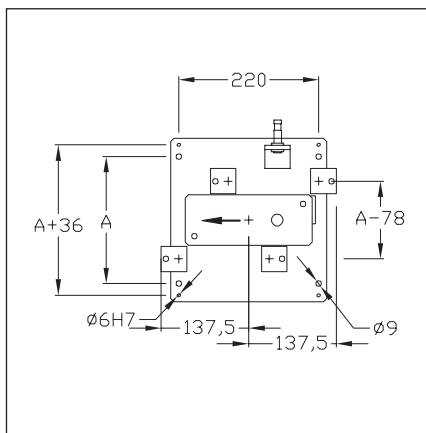
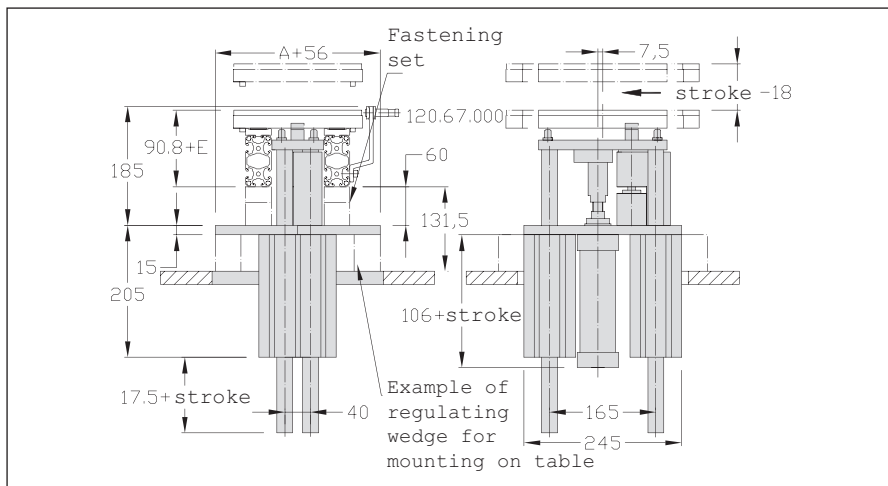

Designation / Dimensions	Order unit	Reference
<b>Lift positioning unit 200</b>	<b>1 pce</b>	<b>120.66.000.R</b>
<b>Lift positioning unit 300</b>	<b>1 pce</b>	<b>130.66.000.R</b>
<b>Lift positioning unit 300x400</b>	<b>1 pce</b>	<b>134.66.000.R</b>
<b>Lift positioning unit 400</b>	<b>1 pce</b>	<b>140.66.000.R</b>
<b>Fastening set</b>	<b>1 set</b>	<b>120.67.000</b>

Specify (R) for spring stopper e.g. 140.66.000 (R)

# Damped lift positioning unit Widths 200-300-400

## Technical data

Complete set including:

- ✗ Stopper
  - 1 double effect cylinder  $\varnothing 32$ , detectable positions
- ✗ Positioning unit
  - 1 double effect cylinder  $\varnothing 50$ , detectable positions
- ✗ Ball bearing guide bush  $\varnothing 25$
- ✗ Fastening parts
- ✗ 1 bracket for shielded mounting sensor M12x100
- ✗ Detection range: 4 mm

 Flow rate controllers G 1/4 should be adapted

A stopper located before the lift unit is generally necessary to avoid the arrival of another workpiece carrier during lifting.

Cylinder strokes available:  
50-80-100-125-160-200-250-300-320-400 mm

Maximum vertical strain: 100 daN at the center of workpiece carrier

Repeatability: +/- 0,06 mm

Weight: 200: 10,7 kg  
300: 19,7 kg  
400: 22,6 kg

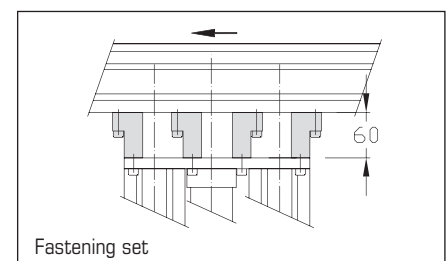
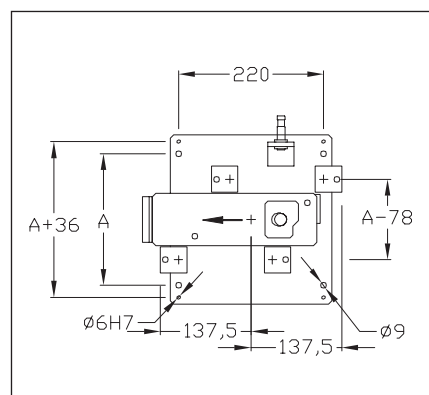
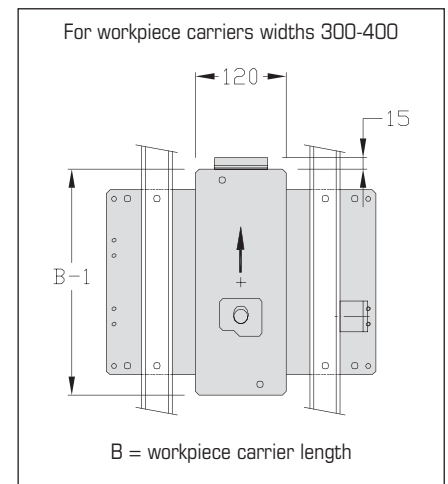
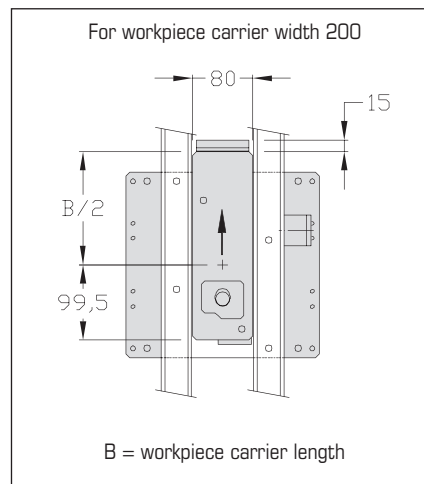
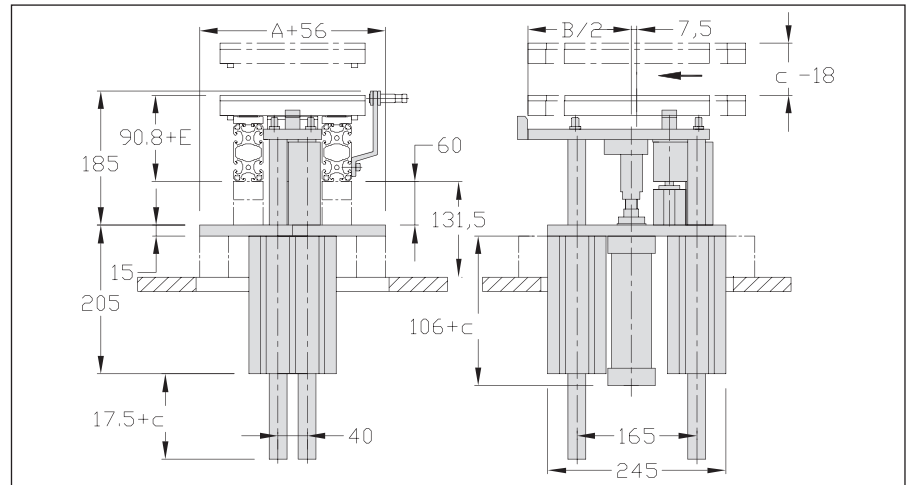

Designation / Dimensions	Order unit	Reference
Damped lift positioning unit 200	1 pce	120.66.000 RA
Damped lift positioning unit 200x250	1 pce	125.66.000 RA
Damped lift positioning unit 200x300	1 pce	123.66.000 RA
Damped lift positioning unit 300	1 pce	130.66.000 RA
Damped lift positioning unit 300x400	1 pce	134.66.000 RA
Damped lift positioning unit 400	1 pce	140.66.000 RA



## Dead man option, lift positioning units Widths 200-300-400

### APPLICATIONS

This option is available for all lift positioning units widths 200 - 300 - 400.

Locking by springs.

Retaining force: 1400 N

Useful pressure range: 6 bars.

 2 flow rate controllers G1/4 +  
1 connection G 1/8 are required.

Weight: 4.2 kg (stroke 400).

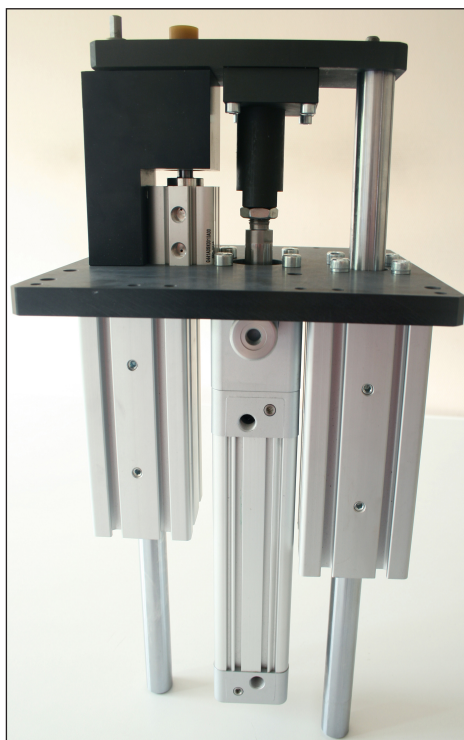
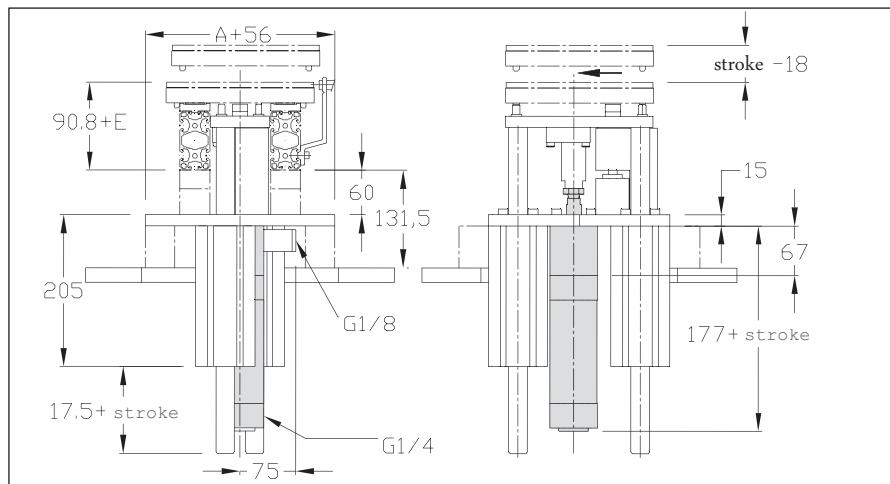

**Designation / Dimensions**

**Dead man option, lift positionig units 200 - 300 - 400**

**Order unit**

**1 pce**

**Reference**

**120.75.000**

## Bridge positioning units Width 200

### Technical data

Complete set including:

- ✘ Stopper  
1 double effect cylinder  $\varnothing 32$ ,  
detectable positions
- ✘ Positioning unit  
1 double effect cylinder  $\varnothing 50$ ,  
detectable positions
- ✘ Ball bearing guide bush  $\varnothing 25$
- ✘ Fastening parts
- ✘ 1 bracket for shielded mounting sensor  
M12x100
- ✘ Detection range: 4 mm

⚠ Flow rate controllers G 1/4  
should be adapted

A stopper located before the unit is  
generally necessary to avoid the arrival of  
another workpiece carrier during lifting.

Cylinder strokes available:  
100-125-160-200-250 mm

Maximum vertical strain:  
60 daN at the center of workpiece carrier.

Repeatability: +/- 1 mm

Weight: 200x200: 30 kg  
200x250: 31,5 kg  
200x300: 33 kg

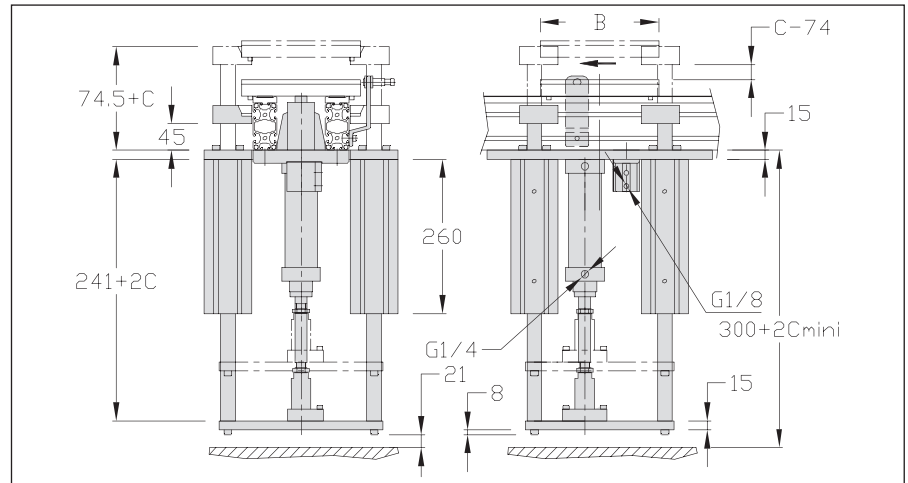

B = workpiece carrier length

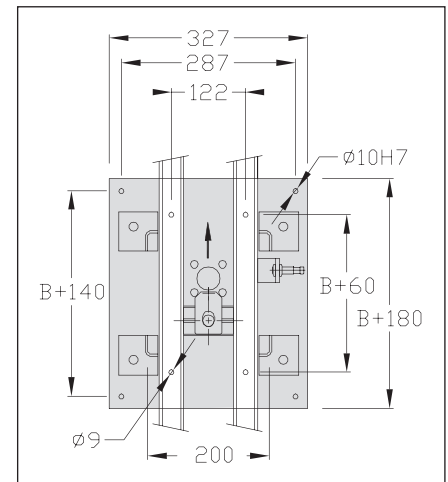

Designation / Dimensions	Order unit	Reference
<b>Bridge positioning unit 200</b>	<b>1 pce</b>	<b>120.71.000</b>
<b>Bridge positioning unit 200 spring</b>	<b>1 pce</b>	<b>120.71.000.R</b>
<b>Damped bridge positioning unit 200</b>	<b>1 pce</b>	<b>120.71.000 RA</b>
<b>Bridge positioning unit 200x250</b>	<b>1 pce</b>	<b>125.71.000</b>
<b>Bridge positioning unit 200x250 spring</b>	<b>1 pce</b>	<b>125.71.000.R</b>
<b>Damped bridge positioning unit 200x250</b>	<b>1 pce</b>	<b>125.71.000 RA</b>
<b>Bridge positioning unit 200x300</b>	<b>1 pce</b>	<b>123.71.000</b>
<b>Bridge positioning unit 200x300 spring</b>	<b>1 pce</b>	<b>123.71.000.R</b>
<b>Damped bridge positioning unit 200x300</b>	<b>1 pce</b>	<b>123.71.000 RA</b>

## Press positioning units Width 200

### Technical data

Complete set including:

- ✘ Stopper
- ✘ Lifting cylinder
- ✘ 2 locking cylinders
- ✘ Fastening parts
- ✘ 2 brackets for shielded mounting sensor M12x100
- ✘ Detection range: 4 mm

 Flow rate controllers G 1/8 should be adapted

The press-positioning unit must be fixed on a frame capable of supporting the strain applied.

Maximum vertical strain

200x200: 3 000 daN

300x300: 5 000 daN

400x400: 5 000 daN

Repeatability: +/- 0,03 mm

Weight: 200x200: 25 kg

300x300: 35 kg

300x400: 42 kg

400x400: 48 kg

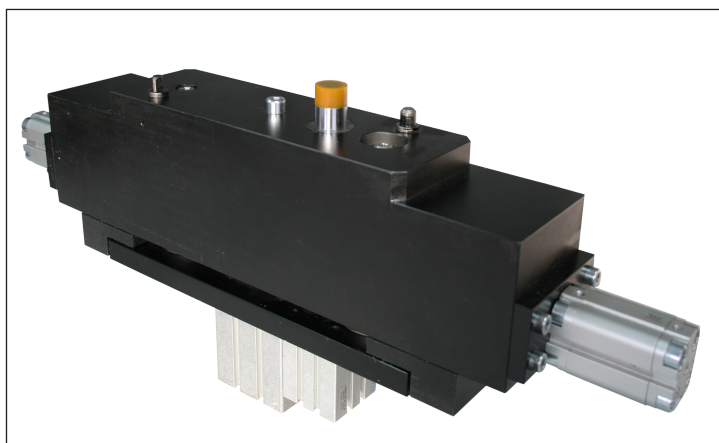
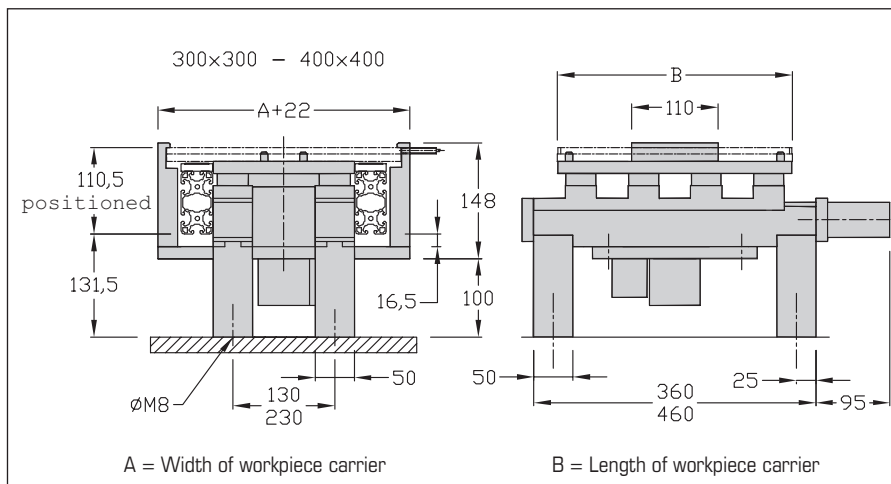
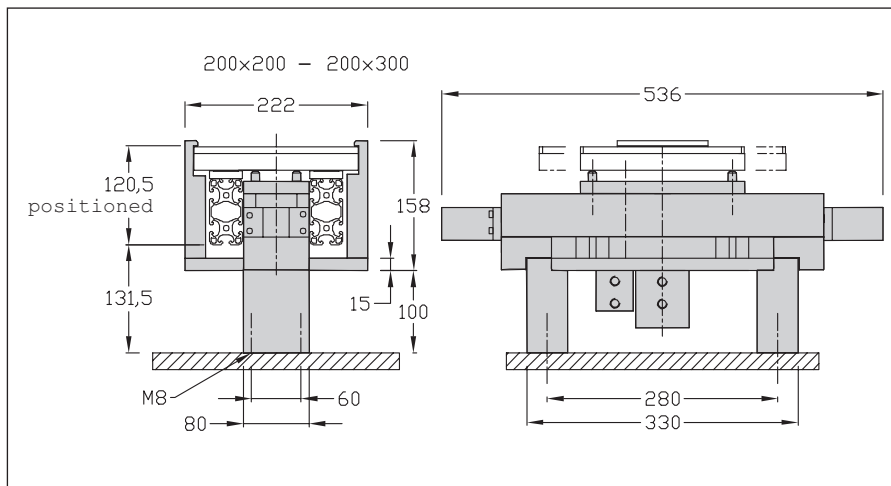

Designation / Dimensions	Order unit	Reference
Press positioning unit 200x200	1 pce	120.33.000 R
Press positioning unit 300x300	1 pce	130.33.000 R
Press positioning unit 300x400	1 pce	134.33.000 R
Press positioning unit 400x400	1 pce	140.33.000 R

Specify (R) for spring stopper e.g. 120.33.000 (R)

# Multi-positioning unit Width 200

## Technical data

Complete set including:

- ✘ Stopper
- ✘ Positioning unit 200
- ✘ Slide PS 20  
stroke: 50-100 or 200

The slide is fitted with shock absorbers and stop screws with integrated sensors.

Maximum vertical strain:  
stroke 50 or 100: 40 daN  
stroke 200: 20 daN

Repeatability: +/- 0,04 mm

 A stopper located before the multi-positioning unit is generally necessary to avoid the arrival of another workpiece carrier during the slide moving.

Multi-positioning units can be made on request.

Weight: 14,5 kg

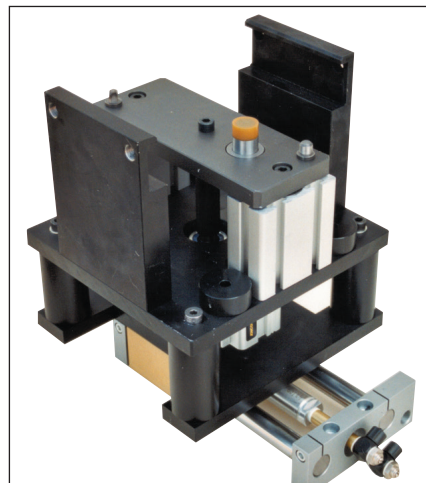
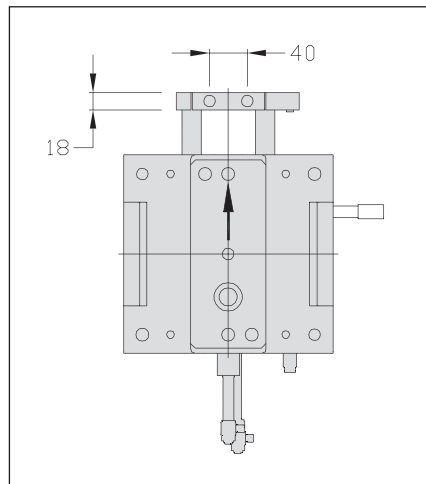
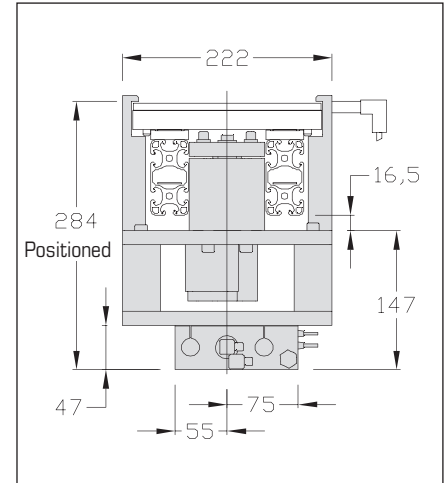
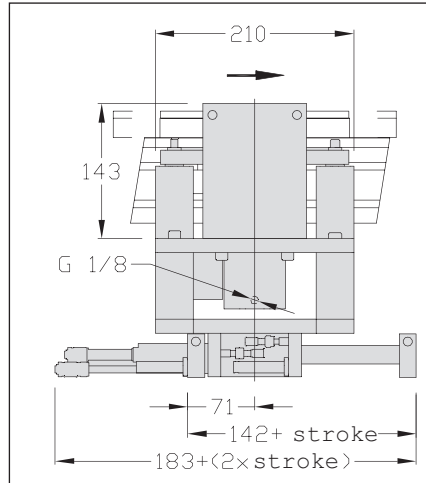

Designation / Dimensions	Order unit	Reference
Multi-positioning unit 200	1 pce	120.72.000.***

(\*\*\* = strokes 50-100-200 eg: stroke 50 120.72.000.050)

## Reinforcements for positioning unit Widths 300-400

### APPLICATIONS

On positioning units and positioning units for station 300, 300x400 and 400, reinforcement bars allow a better force distribution applied on the workpiece carrier and therefore on all the positioning unit surface.

#### Width 300

- ✘ 2 steel bars 180x19 thickness 29
- ✘ Fastening 2x2 Chc M8

#### Width 400

- ✘ 2 steel bars 280x20 thickness 29
- ✘ Fastening 2x2 Chc M8

Weight: 300: 1,25 kg  
400: 2,20 kg

A = Workpiece carrier width  
B = Workpiece carrier length

300

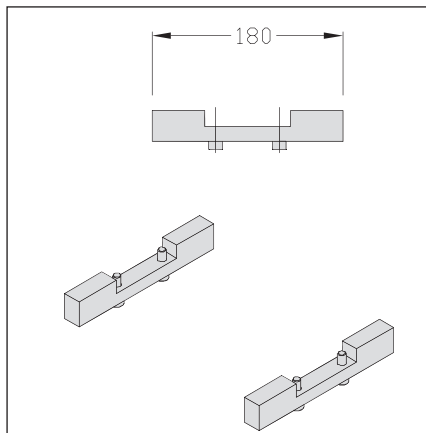

400

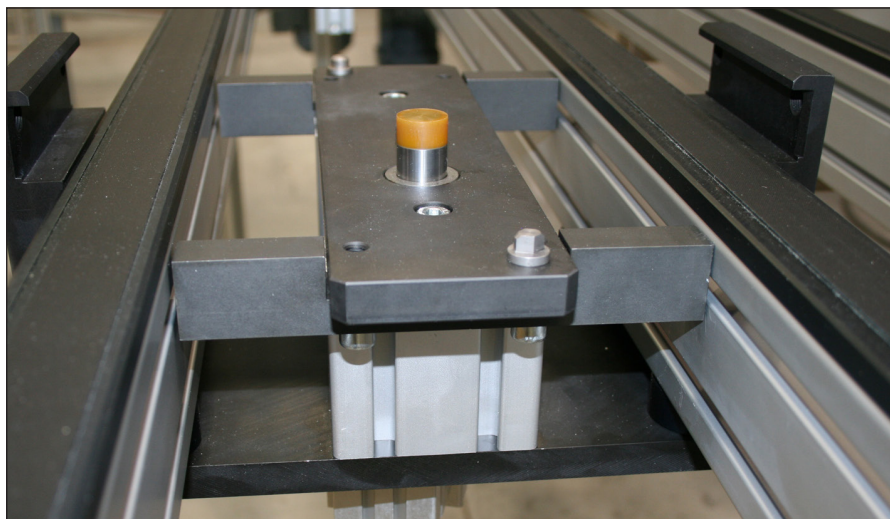
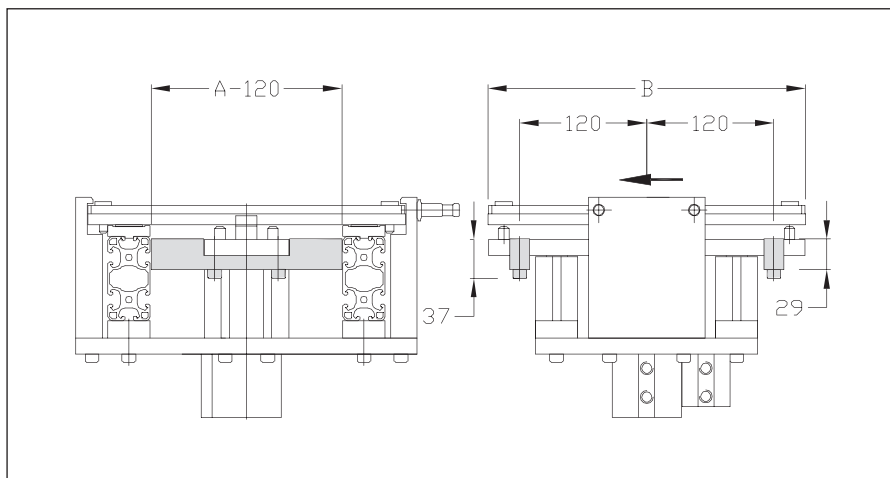
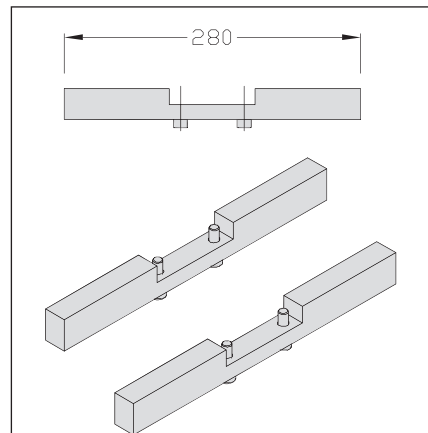

Designation / Dimensions	Order unit	Reference
Reinforcement for positioning unit 300	1 set	130.64.100
Reinforcement for positioning unit 400	1 set	140.64.100

# Module TLM 2000 Heavy loads Width 200

## APPLICATIONS

Used with TLM 2000 flat belt range.

The standard belt guide is replaced by pre-assembled absorbing load modules of length 80 mm, pressed into transfer profiles, thus multiplying the strain on a pallet by 2,5 compared to a standard unit.

The pallet is driven by a belt sliding on ball bearings mounted on springs. The pallet move on ball bearings to reduce the friction coefficient between the pallet and the belt. Define in advance lengths of conveying units to avoid cutting of these modules.

### Technical data

- ✘ Module length 80 mm
- ✘ Fastening with 2 clips
- ✘ External ball bearings pallet support  $\varnothing 10$ , stainless steel
- ✘ Inside ball bearings belt support  $\varnothing 7$ , stainless steel

Maximum load / 6 m:  
2.5 x standard load

Maximum standard load:  
2.5 x standard load

Possible combination of standard belt guide and absorbing load modules by following up application.

Weight : 0.035 kg / module

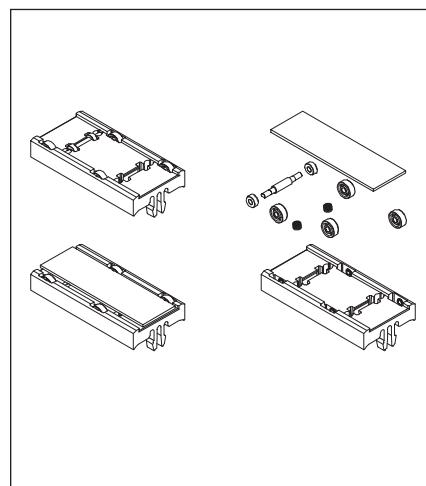
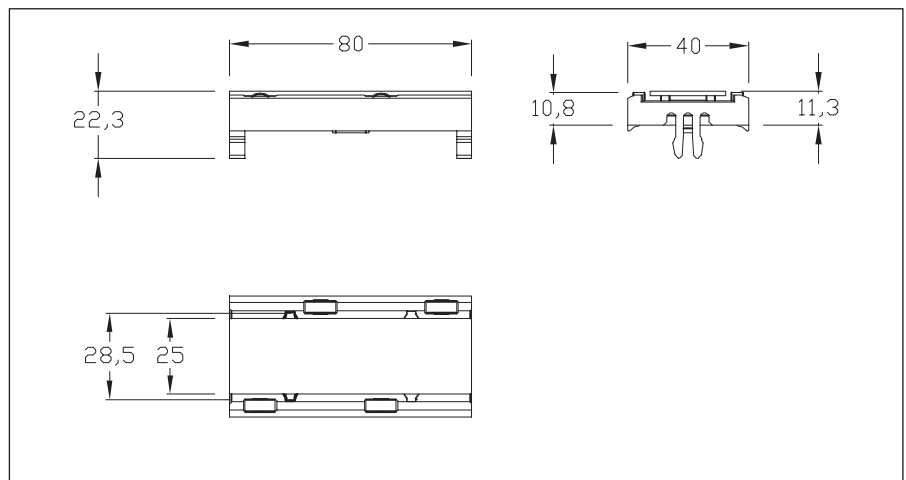
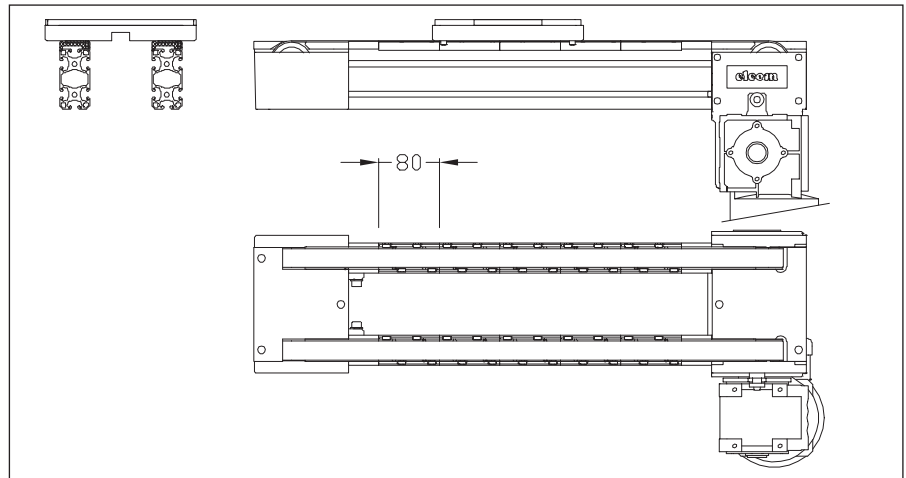

Designation / Dimensions	Order unit	Reference
Module TLM 2000 Heavy loads	1 pce	120.02.000L



## Logic block

### APPLICATIONS

Allows simple identification of workpiece carriers and memorizing information at different stages of the line. The coder consists in a plastic body in which steel ball can only have two stable positions. Coding is done by changing the position of the ball with a micro cylinder. Reading is done by magnetic detection. Resetting can be done simply by running the coder under a fixed cam. One coder is equivalent to 1 byte of memory. Several coders can be placed side by side on the same workpiece carrier.

### Technical data

- ✗ Body, PA black
- ✗ Steel ball  $\varnothing$  10

Weight:

Logic block: 0,018 kg

RAZ: 0,19 kg

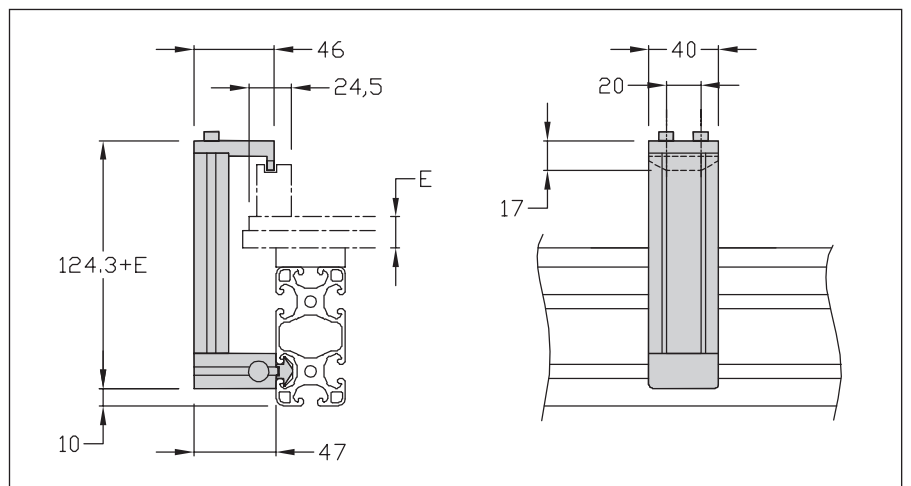
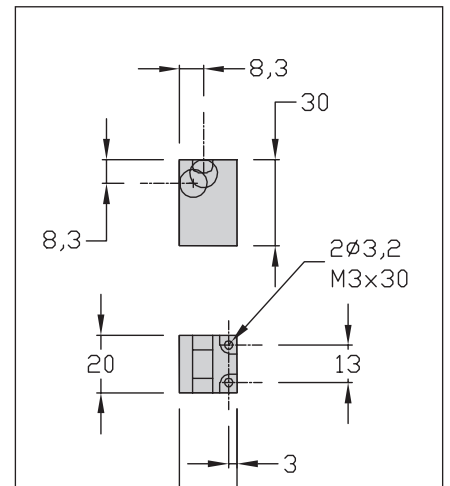
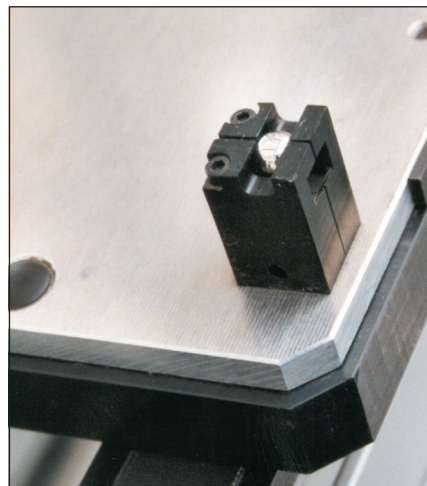
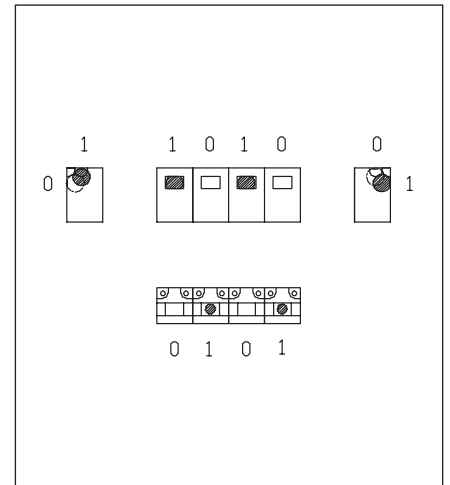
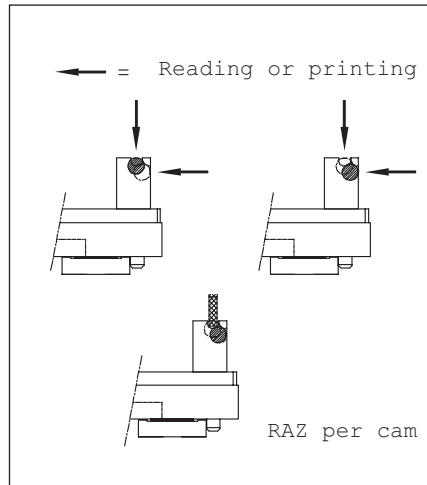

Designation / Dimensions	Order unit	Reference
Logic block	1 pce	100.00.000
RAZ 200	1 pce	100.01.000
RAZ 300-400	1 pce	100.02.000

# Workpiece carrier sensor

## APPLICATIONS

Allows to detect the workpiece carrier's flow in a definite area of the transfer system and allows to know when the workpiece carrier leaves or enter into this area in order to manage accumulations.

Avoid the sensor change of state in this area.

### Technical data

- x Plastic body
- x Steel detection bar



Sensor M12x100, reach of 4 mm shielded sensor not supplied

Weight: 0,23 kg

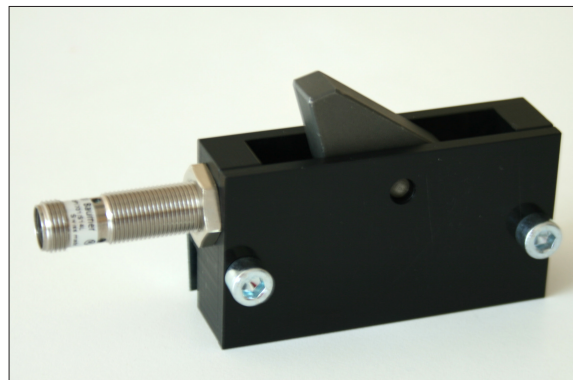
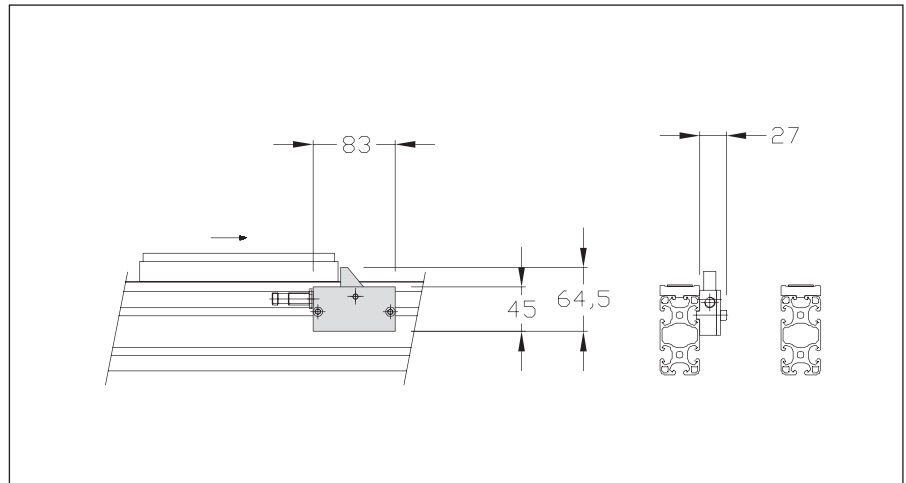

Designation / Dimensions	Order unit	Reference
Workpiece carrier sensor	1 set	200.20.000

## Sensor brackets M 12 x 100

### APPLICATIONS

M12x100 sensor bracket for workpiece carrier.

#### Technical data

- ✘ Cast aluminium
- ✘ Nut 8 St M6 + screws
- ✘ Detection range: 4 mm

Weight: 200: 0,1 kg  
 300: 0,1 kg  
 400: 0,1 kg

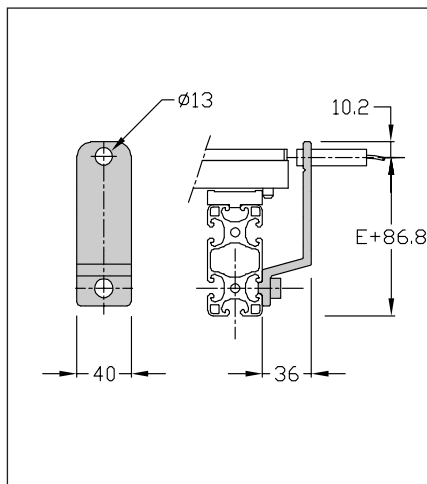

Designation / Dimensions	Order unit	Reference
Sensor bracket 200	1 pce	120.10.000
Sensor bracket 300-400	1 pce	140.10.000

## Positioning kit

### APPLICATIONS

Allows accurate positioning unit on station.

#### Technical data

- ✘ 2 axis screws M8
- ✘ 2 hexagonal socket head cap screws M8

Weight: 0,08 kg

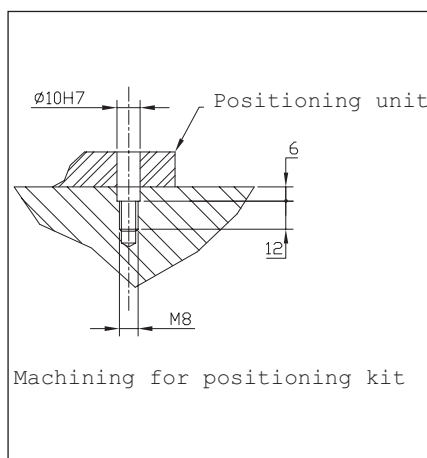

Designation / Dimensions	Order unit	Reference
Positioning kit	1 set	120.62.000

## Anti bouncing back

### APPLICATIONS

Avoids workpiece carrier bouncing back on stoppers or positioning units in case of high speed. Allows to reduce the changing time of workpiece carriers in the positioning units.

#### Technical data

- x** Parts, PA black
  - x** Fastening parts
- Weight: 0,1 kg

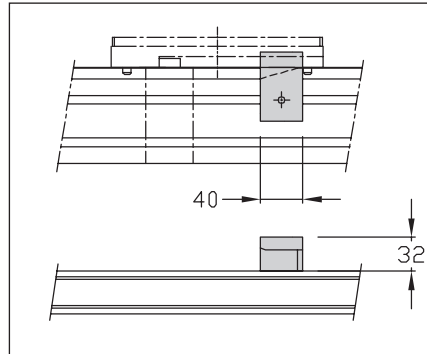

Designation / Dimensions	Order unit	Reference
<b>Anti bouncing back 200</b>	<b>1 set</b>	<b>120.30.000</b>

## Inductive sensor M 12x100

### APPLICATIONS

Detection for the workpiece carrier.

#### Technical data

- x** Shielded mounting sensor M12x100
- x** LED control display
- x** PNP-10-30 VDC
- x** Screwed connection
- x** Cable 5 m



Designation / Dimensions	Order unit	Reference
<b>Inductive sensor M 12x100</b>	<b>1 set</b>	<b>200.10.200</b>

## Cylinder sensors

### APPLICATIONS

Detection the position of cylinders, stoppers or positioning units.

#### Technical data

- x** 12-27 V-LED control display

Designation / Dimensions	Order unit	Reference
<b>Cylinder sensor, positioning unit</b>	<b>1 set</b>	<b>200.10.201</b>
<b>Cylinder sensor, lift positioning unit</b>	<b>1 set</b>	<b>200.10.202</b>

Derivation module  
p 194

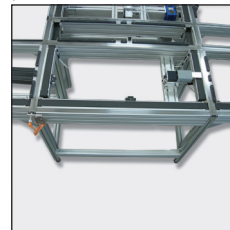

Workpiece carrier  
p 187



Angle  
p 194

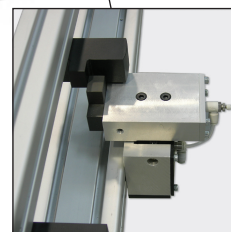
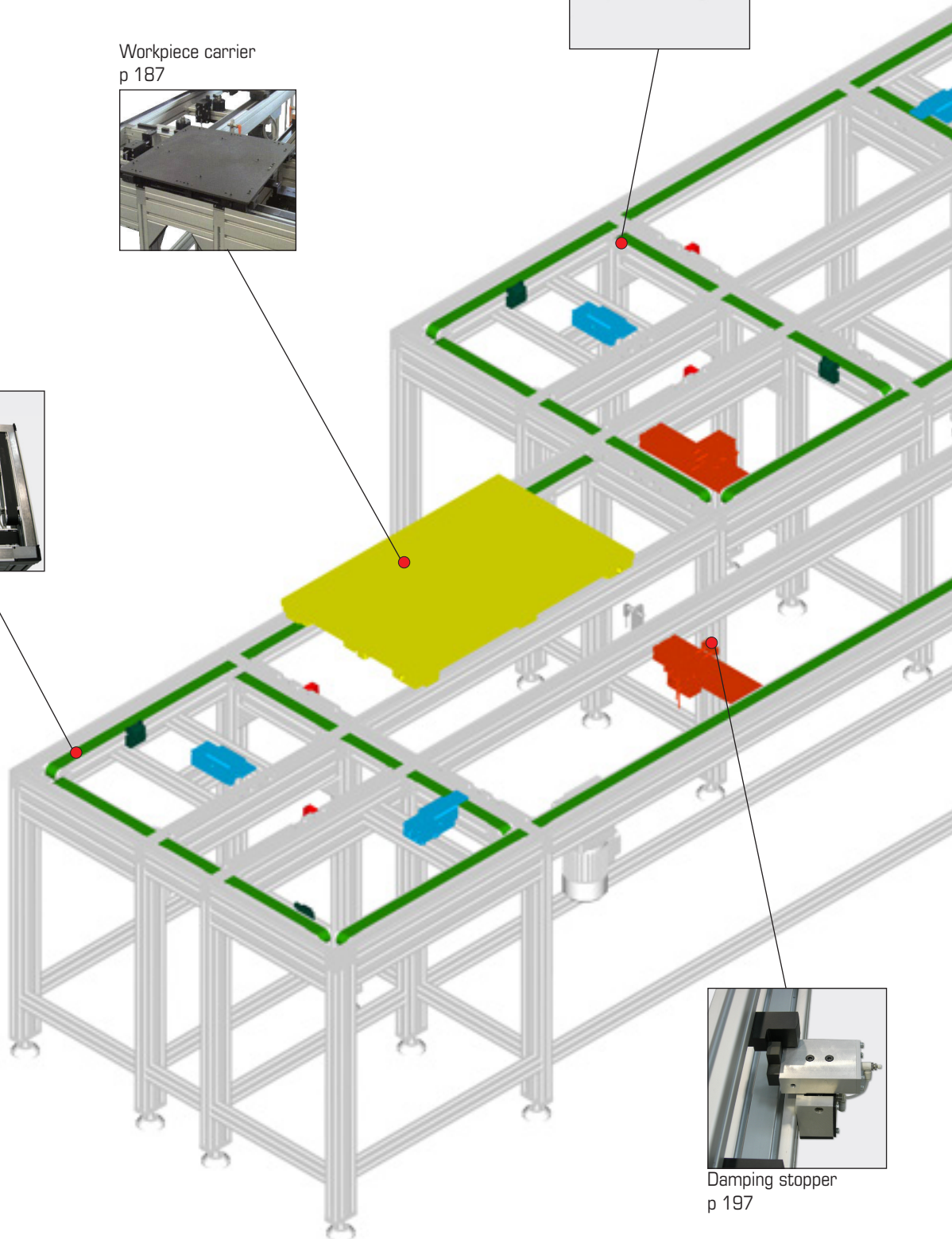
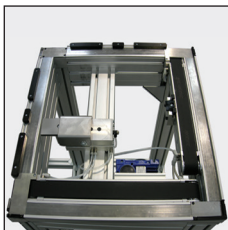

Damping stopper  
p 197



Conveying unit  
p 190

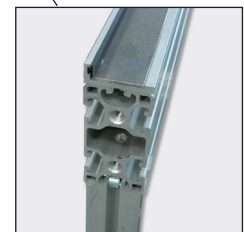
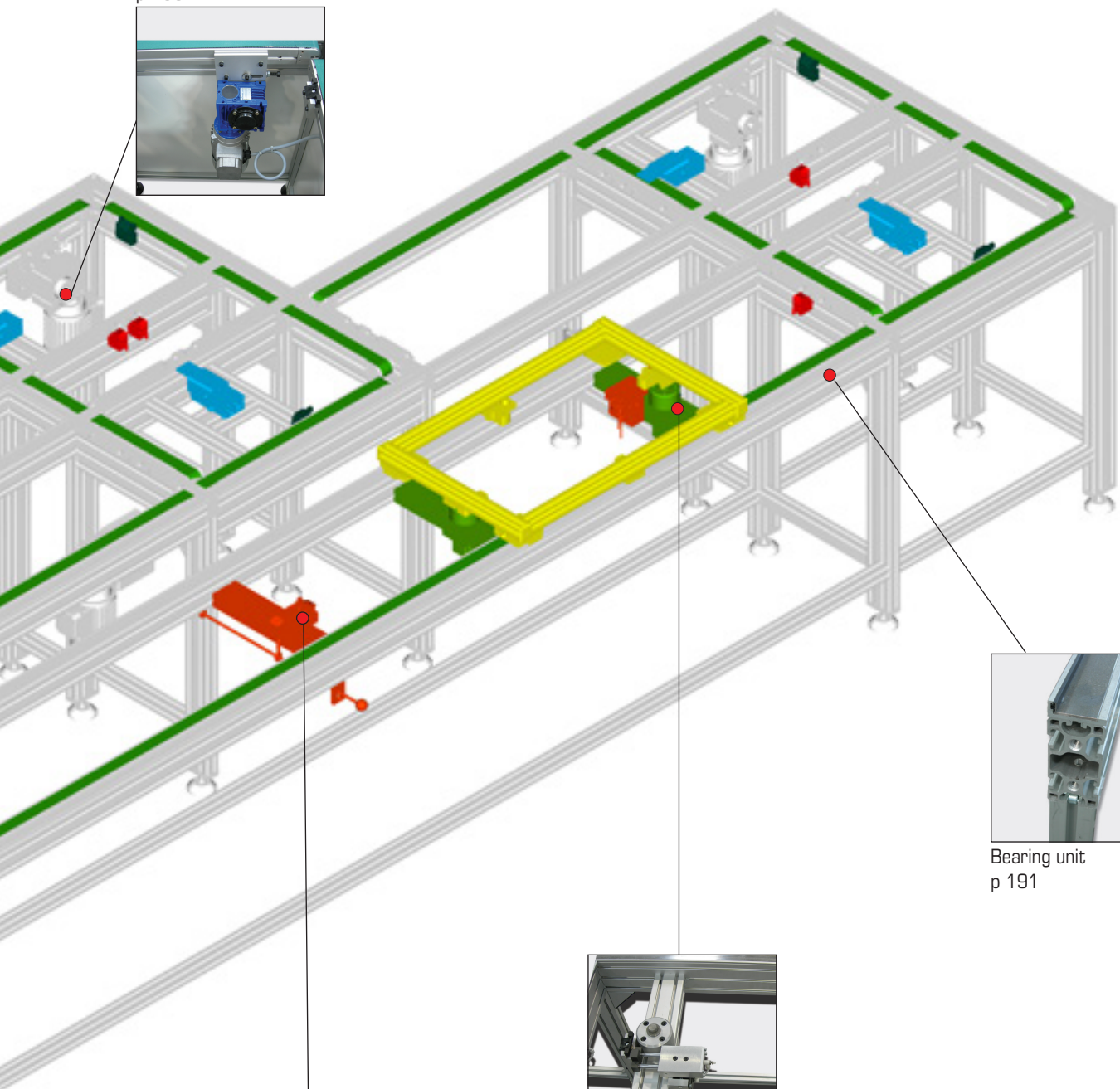
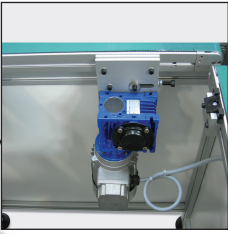

Bearing unit  
p 191

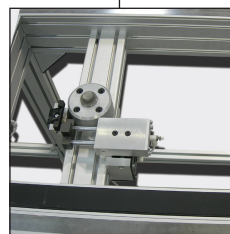

Positioning unit  
p 198

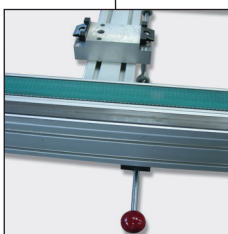

Manual stopper  
p 196



## Index TLM 5000

Designation	Page
Data .....	185
General principle .....	186
Workpiece carriers .....	187
Workpiece carrier base .....	188
Above workpiece carriers Widths 500-600-800-1000 .....	189
Drive units .....	190
Drive units Widths 500-600-800-1000 .....	191
Light and heavy stands .....	192
Sensor bracket M12x100 .....	192
Cuts and straight joinings .....	193
Spacers Widths 500-600-800-1000 .....	193
Angles .....	194
Stoppers .....	196
Manual stopper .....	196
Damping stoppers .....	197
Positioning unit .....	198
Inductive sensor M12x100 .....	199
Inflatable belt drive transfer .....	200
Inflatable belt conveyor holder .....	204

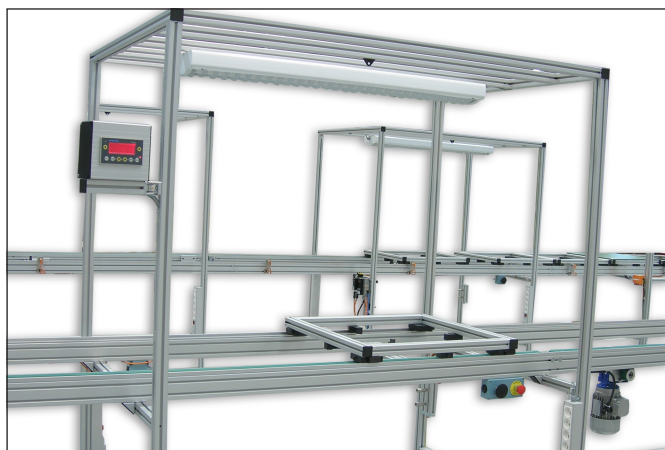

Download all CAD 3D files



on our website  
[www.elcom-automation.com/transfers](http://www.elcom-automation.com/transfers)

## Data

Workpieces carriers (mm) * Possibility => 1500	500 x 500      500 x 800 500 x 1000*    600 x 600 600 x 800      600 x 1000* 800 x 800      1000 x 1000
Load/workpiece carrier (daN)	50
Speed (m/min)	10-12
Length of conveying unit Mini Maxi	500 6000
Maxi accumulation load per motor (daN)	400 or 75 %
Motor power (380 V three-phase)	0,25 KW-0,83 A

The maximum length of the conveying units is: 6 000 mm.

For long spans, several elements can be joined end to end.

For important accumulations, the length of the conveying units is adapted to the load.

It is recommended to place sensors in order to control accumulation of the load.

Pneumatic cylinders must be equipped with flow rate controllers.

It is possible for long spans to be cut in order to facilitate the dismantling of the machines.

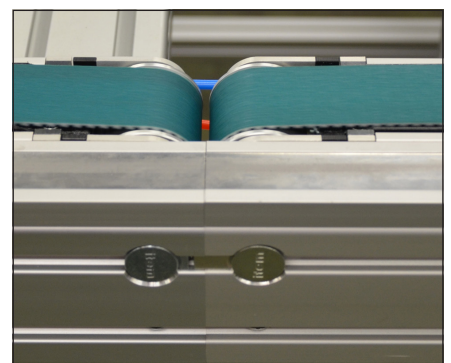
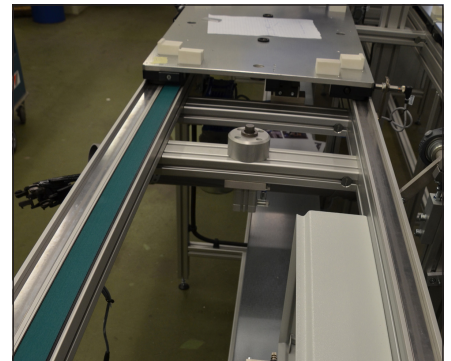

## General principle

Workpiece carriers are used to support and position the components during the process.

Flexible and economical industrial system adapted to convey large workpiece carriers 500x500 to 1000x1000.

Workpiece carriers (of various materials), fitted with multidirectional rollers, are conveyed on stainless steel treads, allowing high loads.

The conveying of workpiece carriers is carried out by belt driving units with controlled pneumatic pressure. For a manual moving of the workpiece carrier, some sections are available without driving.

A pneumatic management device put in each angle allows the damping and the automatic change of direction of the workpiece carrier (without PLC).

The modular design of TLM 5000 transfer system allows to optimize the dimensions of workpiece carriers to conveyed components.

Further extensions and modifications can be easily made.



## Workpiece carriers

The modular conception of TLM 5000 allows large architectures of workpiece carriers.

Multidirectional rollers ensure the rolling of workpiece carriers. They are integrated in PA angles which are fixed under the 4 angles of the workpiece carrier.

PA blocks consist in:

- ✘ 1 shock absorber to limit the shock between the workpiece carriers and to reduce the noise.
- ✘ 1 multidirectional roller
- ✘ 1 detection bar to ensure the control of workpiece carriers.

The drive is ensured by angle blocks and by the central base (one, two or three depending the dimension of workpiece carrier).

The central base allow a quick start of workpiece carriers in corners and the stop of workpiece carrier on stoppers.

Two centering bushes ensure the position on positioning units.

Various plates are usable according to the size and application:

- ✘ Aluminium profile 40x40 or other
- ✘ Aluminium plate, thickness: 8, 10, 12 or 16 mm
- ✘ Steel plate
- ✘ Beech multi-ply plate
- ✘ Plastic plate

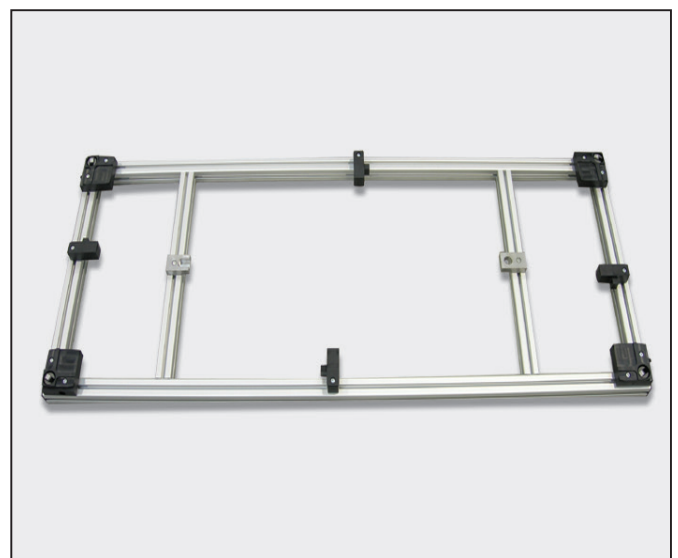
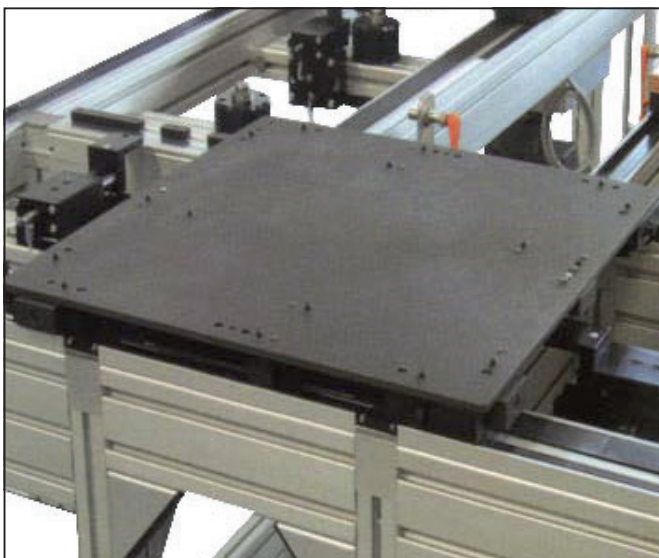
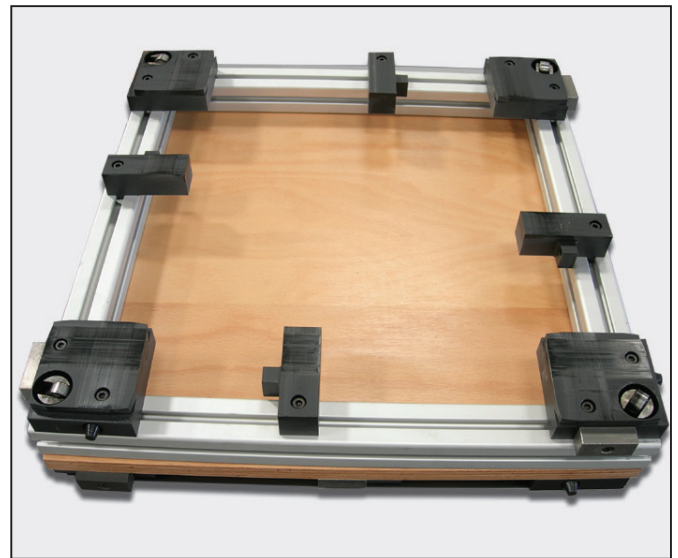
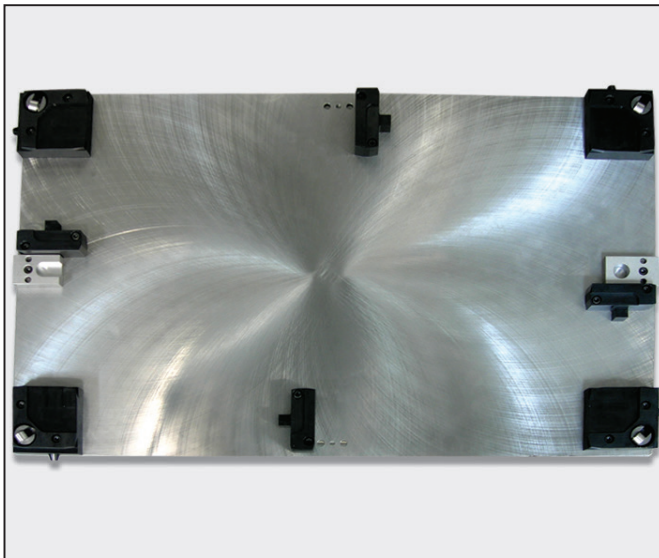



## Workpiece carrier base

### Technical data

#### Square workpiece carrier

- ✘ 4 angle blocks equipped with:
  - \* multidirectional roller
  - \* shock absorber
  - \* plaquette de détection
- ✘ 4 central base

#### Rectangular workpiece carrier

- ✘ 4 angle blocks equipped:
  - \* multidirectional roller
  - \* shock absorber
  - \* detection bar
- ✘ 6 central base

Option: bush set

- ✘ 2 steel bushes

Option: bush set profile

- ✘ 2 steel bushes

Note: 2 bushes per workpiece carrier should be adapted in case of indexing in 2 directions

Weight:

Square workpiece carrier: 1,5 kg

Rectangular workpiece carrier: 2 kg

Bush: 0,5 kg

Bush profile: 0,7 kg

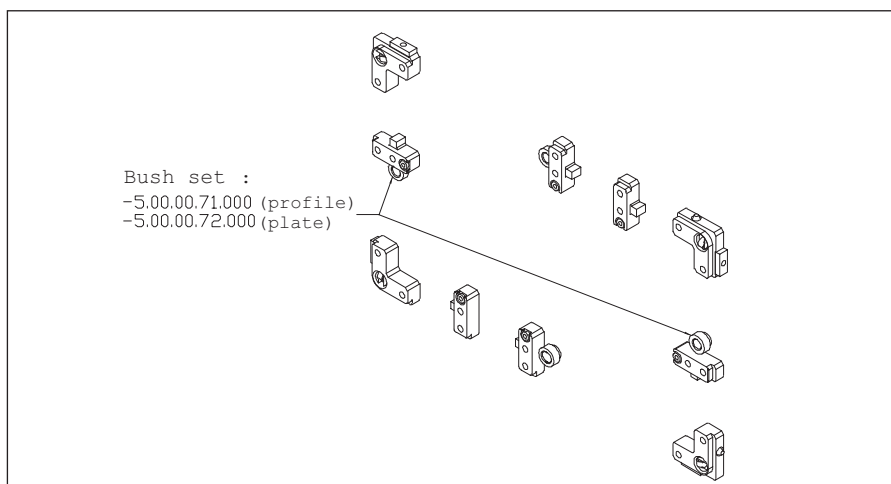
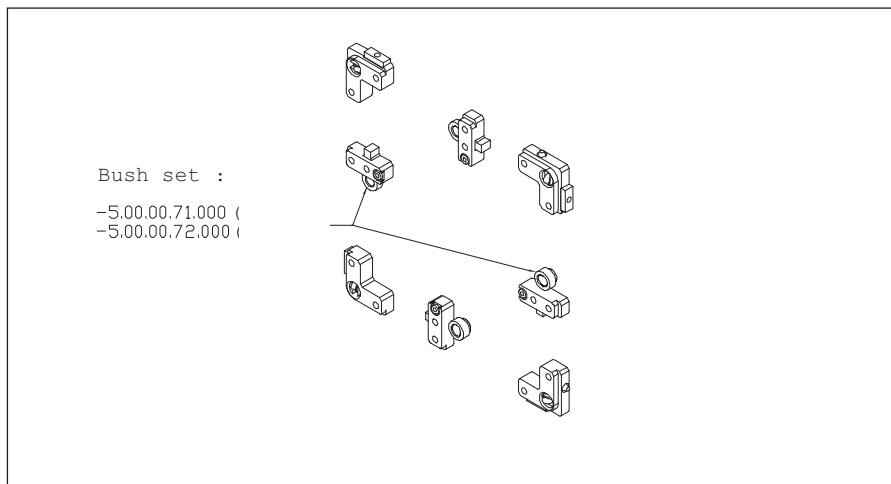

Designation / Dimensions	Order unit	Reference
<b>Square workpiece carrier</b>	<b>1 set</b>	<b>5.00.00.91.000</b>
<b>Square workpiece carrier profile</b>	<b>1 set</b>	<b>5.00.00.90.000</b>
<b>Rectangular workpiece carrier</b>	<b>1 set</b>	<b>5.00.00.91.100</b>
<b>Rectangular workpiece carrier profile</b>	<b>1 set</b>	<b>5.00.00.90.100</b>
<b>Bush</b>	<b>1 set</b>	<b>5.00.00.72.000</b>
<b>Bush profile</b>	<b>1 set</b>	<b>5.00.00.71.000</b>

# Above workpiece carriers Widths 500-600-800-1000

## Technical data

### Profile workpiece carrier

- ✘ Frame in aluminium profile 40x40

### Plate workpiece carrier

Option:

- ✘ Aluminium
- ✘ Thickness: 8, 10, 12 or 16 mm
- ✘ Steel
- ✘ Beech multi-ply
- ✘ Plastic

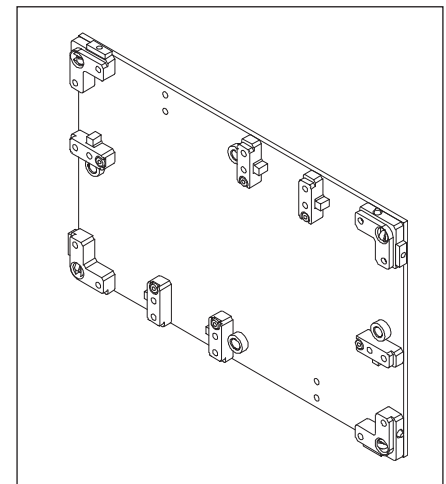
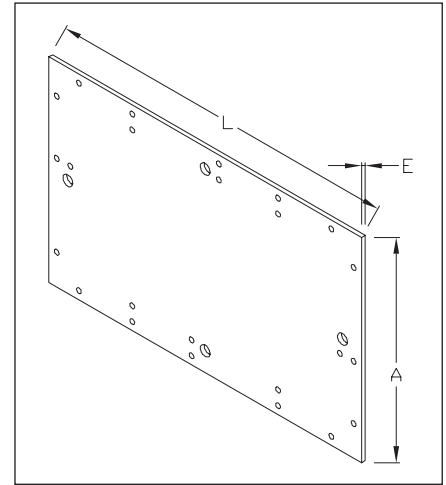
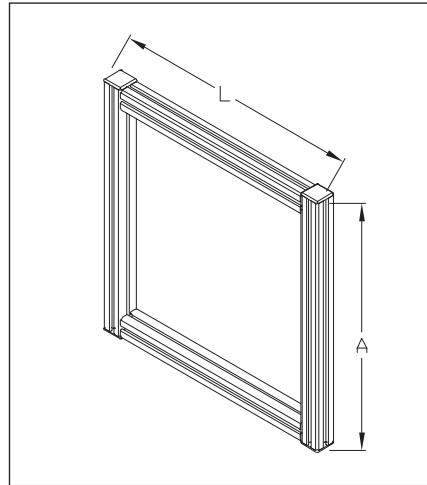



## Drive units

### APPLICATIONS

Drive unit including:

#### x Bearing part

Maxi length: 6 m

The rollers, placed under the workpiece carrier, roll on a steel strip which enables a move without any effort and a durability.

The load is supported by a profile 80x40 which is surmounted by a support profile strip ensuring a great rigidity.

#### x Drive part

Maxi length: 6 m

The inflatable unit ensures the move of the workpiece carrier.

A timing belt, (continuously running) is supported by a plastic slide strip in which a pneumatic membrane exerts a vertical force. Adjustment of the air pressure in the membrane can vary the thrust force under the workpiece carrier.

To maximize the number of motors, it is recommended to use the same unit in angles.

In many lean applications, the bearing part is used alone and the workpiece carriers are manually conveyed from workstation to workstation.

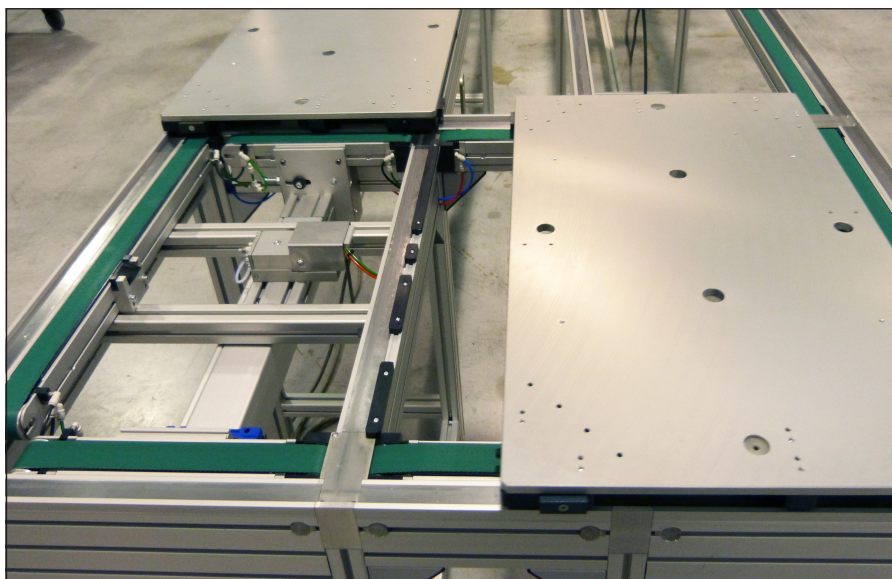
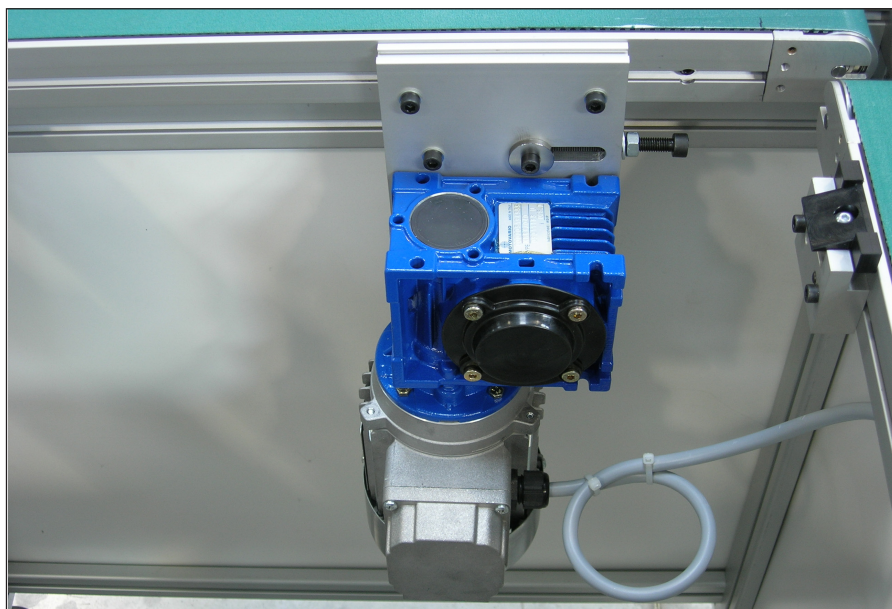
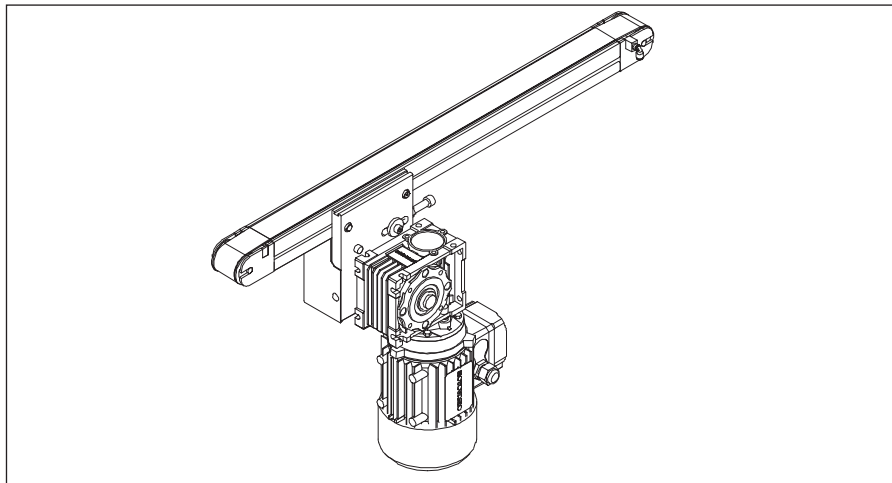

## Drive units Widths 500-600-800-1000

### Technical data

Drive part:

✘ Maxi length: 6 m

✘ Maxi filling ratio: 75%

A = Workpiece carrier's width



Maximum load on workpiece carrier:  
400 daN

Weight:

Drive unit: 11 kg + 2 kg/m

Double drive unit: 18 kg + 4 kg/m

Bearing unit: 7 kg/m

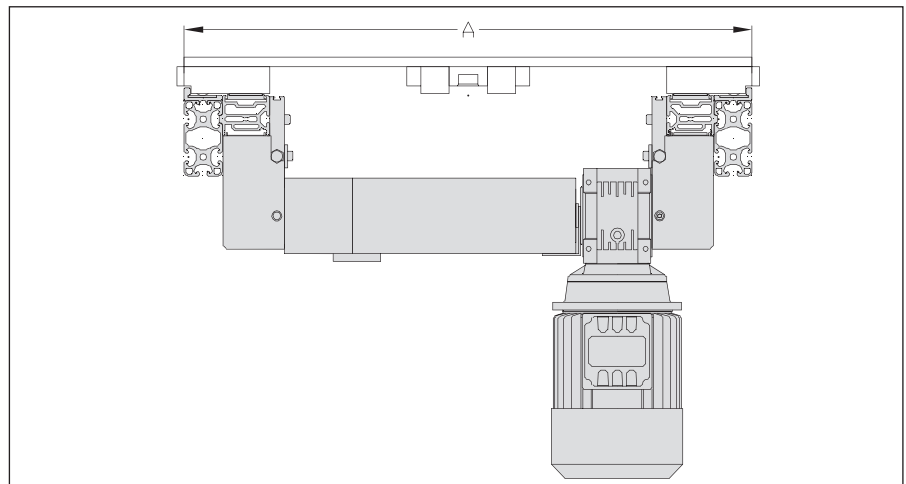
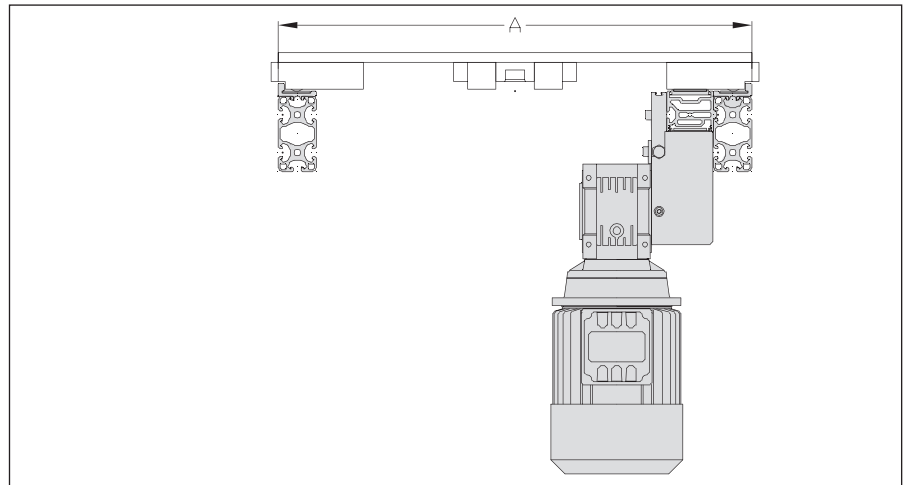

Designation / Dimensions	Order unit	Reference
<b>Drive unit 5000</b>	<b>1 pce</b>	<b>5.00.00.86.000</b>
<b>Double drive unit 5000</b>	<b>1 pce</b>	<b>5.XX.00.87.000</b>
<b>Bearing unit</b>	<b>1 pce</b>	<b>5.00.00.80.000</b>

XX = Width of workpiece carrier A eg: if the width of workpiece carrier A = 500, XX=05

## Light and heavy stands

### Technical data

#### Light

used only as bracket, the longitudinal stress are stood by a station or a by a rigid frame (1 stand every 1,5 m).

#### Heavy

Used when the transfer ensures rigidity. According to the loads, reinforcing pieces are necessary.

Weight:

Light stand: 3,5 kg

Heavy stand: 6 kg

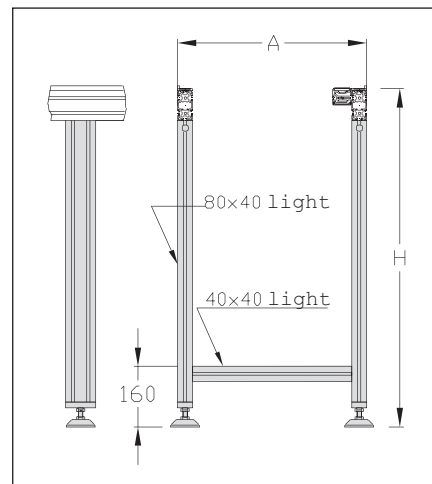
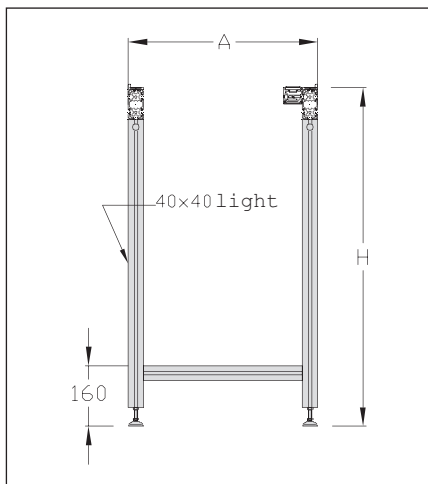

Designation / Dimensions	Order unit	Reference
<b>Light stand</b>	<b>1 pce</b>	<b>5.XX.00.15.000</b>
<b>Heavy stand</b>	<b>1 pce</b>	<b>5.XX.00.16.000</b>

XX = Width of workpiece carrier A eg: if the width of workpiece carrier A = 500, XX=05

## Sensor bracket M12x100

### APPLICATIONS

Bracket for workpiece carrier M12x100 sensor

#### Technical data

- ✘ Cast aluminium
- ✘ Nut 8 St M6 + screws
- ✘ Detection range: 4 mm

Weight: 0,1 kg

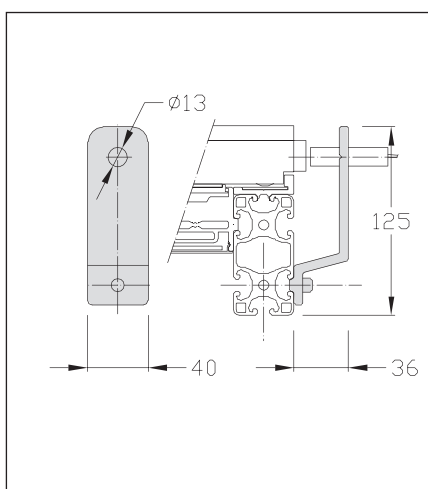

Designation / Dimensions	Order unit	Reference
<b>Sensor bracket M12x100</b>	<b>1 pce</b>	<b>140.10.000</b>

## Cuts and straight joinings

### APPLICATIONS

The cuts allow division of conveyor lengths to make the transport and installation of the line easier.

They also enable building significant lengths.

 Inflatable units cannot be cut.

### Technical data

**x** 6 double universal fastenings

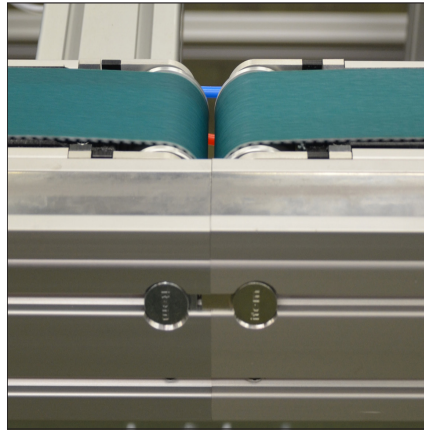

Designation / Dimensions	Order unit	Reference
<b>Conveyor cut</b>	<b>1 cut</b>	<b>120.02.000.B</b>

## Spacers Widths 500-600-800-1000

### APPLICATIONS

 If the length of the conveying unit is >1,5 m, spacers have to be fitted between the profiles 8 80x40.  
(1 spacer every 1,5 m).

### Technical data

**x** Profile 8 40x40 light

**x** 2 universal fastenings

Weight: 500: 0,8 kg  
600: 1 kg  
800: 1,3 kg  
1000: 1,6 kg

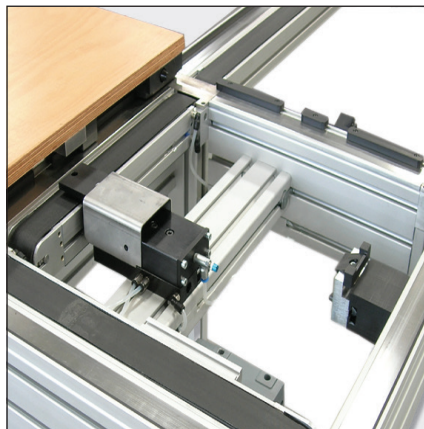

Designation / Dimensions	Order unit	Reference
<b>Spacer 500</b>	<b>1 pce</b>	<b>5.05.00.82.000</b>
<b>Spacer 600</b>	<b>1 pce</b>	<b>5.06.00.82.000</b>
<b>Spacer 800</b>	<b>1 pce</b>	<b>5.08.00.82.000</b>
<b>Spacer 1000</b>	<b>1 pce</b>	<b>5.10.00.82.000</b>



## Angles

Angle modules ensure moving of workpiece carrier into angles without automatism.

The angle is self-supporting, it is supplied with 4 rigid feet, 2 inflatable units set in parallel and piloted by a pneumatic shock absorber. An output valve ensures the reset of the shock absorber.

Rectangular workpiece carriers have 2 units which are set in parallel on the same motorization.

With automatic control, it is not possible to perform an operation or an accumulation in the angle.

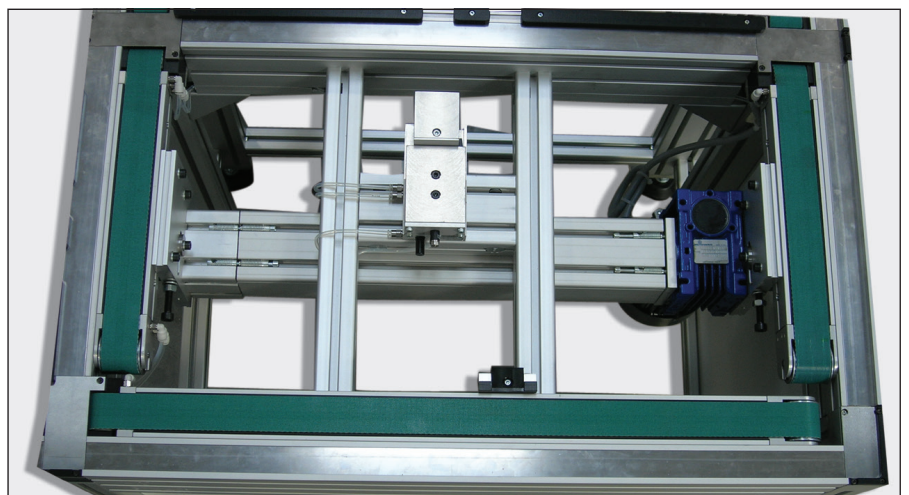

# Angles

## Technical data

- ✘ Structure with aluminium profile
- ✘ Adjustable shock absorber with piloting device
- ✘ 1 anti bouncing back device
- ✘ Reset valve
- ✘ Guides for workpiece carrier

Weight: 35 kg

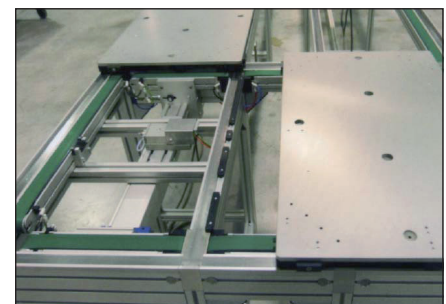
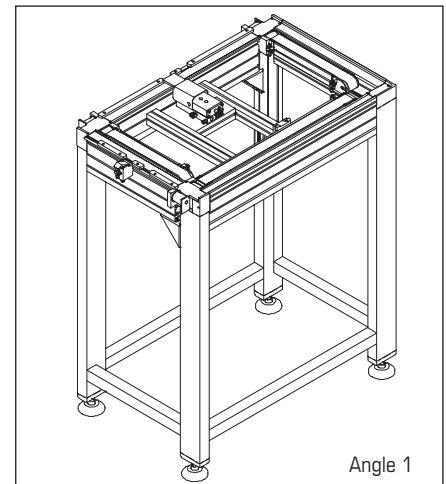
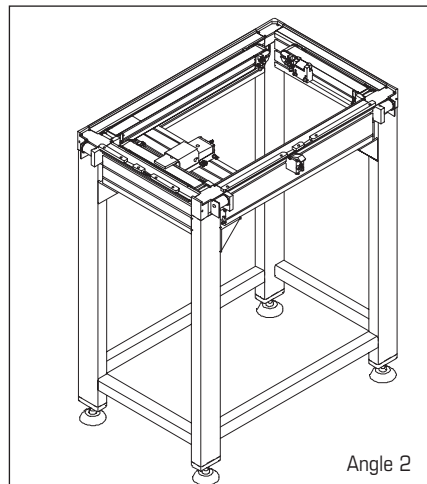
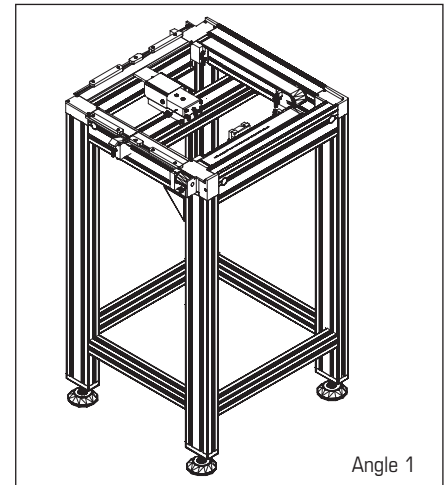
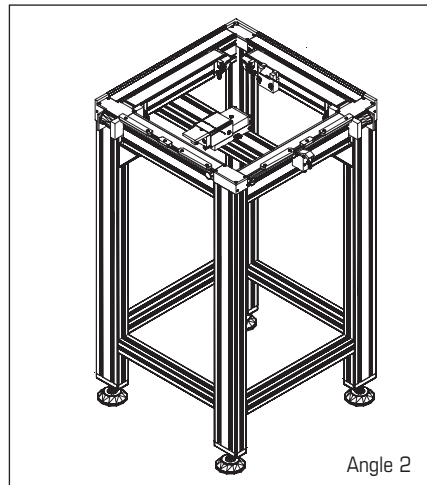

TLM 5000

Designation / Dimensions	Order unit	Reference
Angle 2	1 pce	5.XX.YY.21.000
Angle 1	1 pce	5.XX.YY.20.000

XX = ref. of width workpiece carrier A YY = ref. of the length of workpiece carrier  
eg: workpiece carrier 500x800, reference = 5.05.08.20.000



## Stoppers

### APPLICATIONS

Stopping workpiece carriers during processing requiring no accuracy.

### Manual stopper

The manual stopper is used for lean applications, it doesn't require management. For workpiece carriers with less than 30 kg. Stopper with anti bouncing back device.

#### Technical data

**x** The operator releases the workpiece carrier.

Weight: 1,7 kg

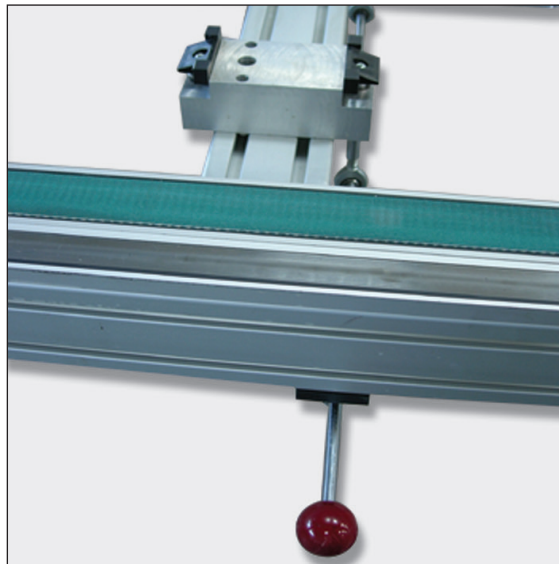
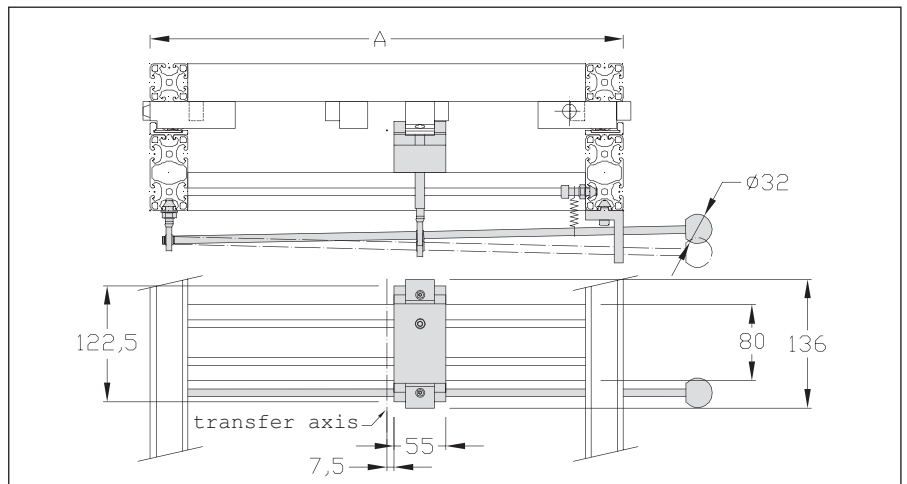

Designation / Dimensions	Order unit	Reference
Manual stopper	1 pce	5.XX.00.12.000

XX = Width of workpiece carrier A eg: if the width of workpiece carrier A = 500, XX=05

## Damping stoppers

Pneumatic stopper: used on manual workstation or to manage accumulations, it allows the stop of workpiece carriers from the front or rear.

Stoppers are equipped with an adjustable pneumatic shock absorber to ensure a stop without shock of workpiece carrier. Reset is automatic.

The workpiece carrier can be stopped on the front or the rear. Depending on the direction of workpiece carrier arrival, there are left and right stoppers.

For lean applications, the control can be done by a button or a pneumatic pedal.

Anti bouncing back option:

Prevents bounces of workpiece carriers when stopping on the stoppers.

For lean applications, this option prevents the back up of workpiece carriers.

Weight: 1,3 kg

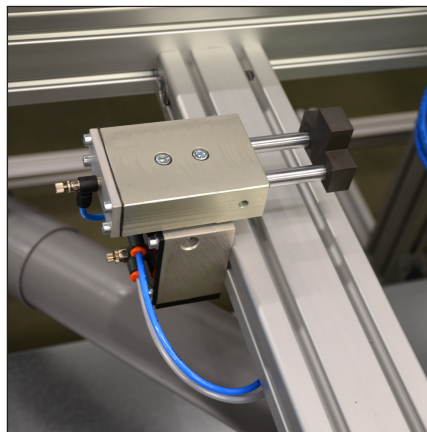
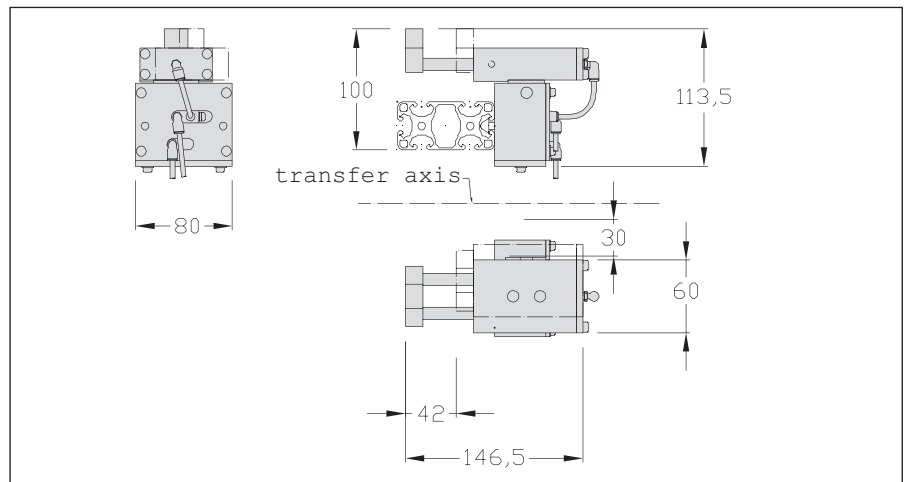
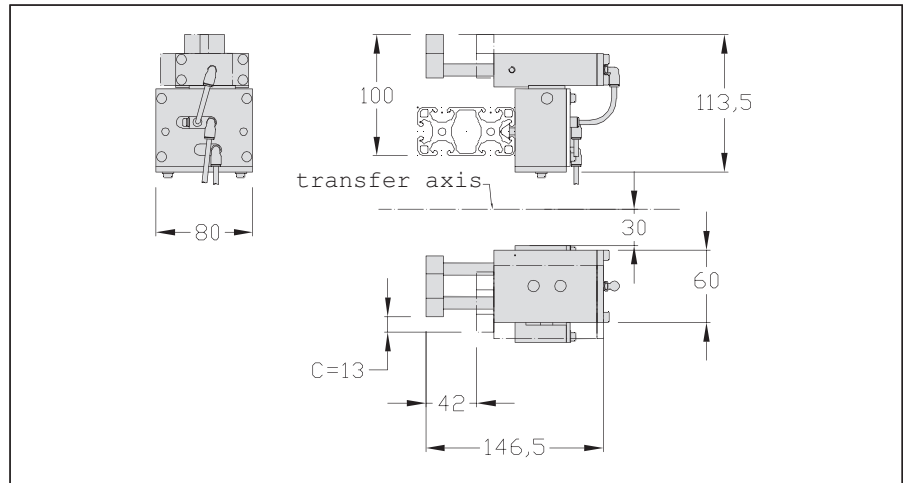

Designation / Dimensions	Order unit	Reference
<b>Damping stopper right</b>	<b>1 pce</b>	<b>5.00.00.10.000</b>
<b>Damping stopper left</b>	<b>1 pce</b>	<b>5.00.00.11.000</b>
<b>Anti bouncing back for pneumatic stopper</b>	<b>1 pce</b>	<b>5.00.00.62.000</b>

## Positioning unit

### APPLICATIONS

Stopping and positioning workpiece carriers for operations requiring accuracy.

The workpiece carrier is stopped by a damping stopper, then positioned by a locating pin system.

No vertical movement of the workpiece carrier.

Positioning unit can be equipped with anti-bouncing back device.

### Technical data

- ✘ 2 cylinders Ø 32
- ✘ 4 flow rate controllers 1/8 + bushes should be adapted

Repeatability with:

aluminium or steel plate: +/- 0.05  
frame profile: +/- 0.2

Load maxi 100 kg.

Pay attention to the workpiece carrier bending.

Supplied with 1 sensor bracket.

Forecast 1 sensor M12x100 detection range 4 mm has to be adapted.

Weight: 7 kg

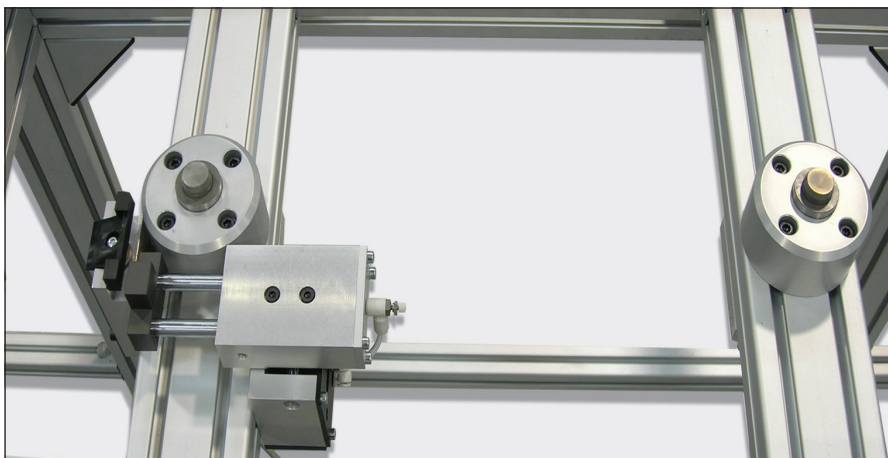
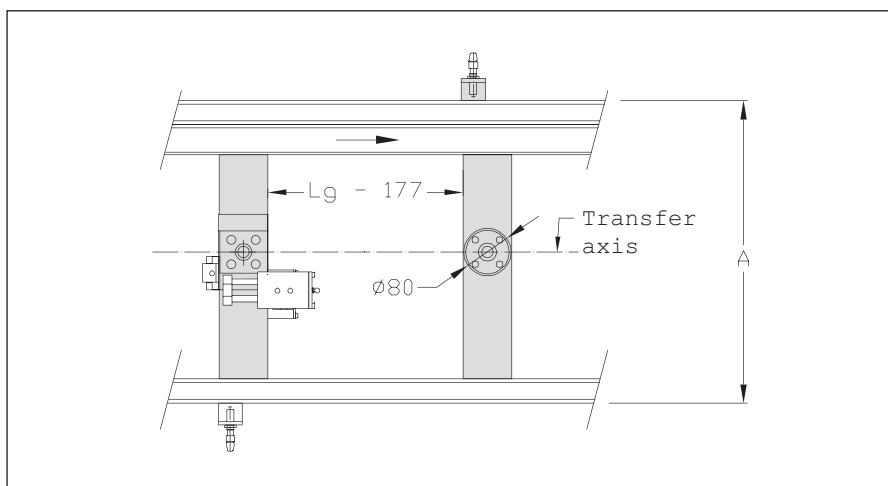
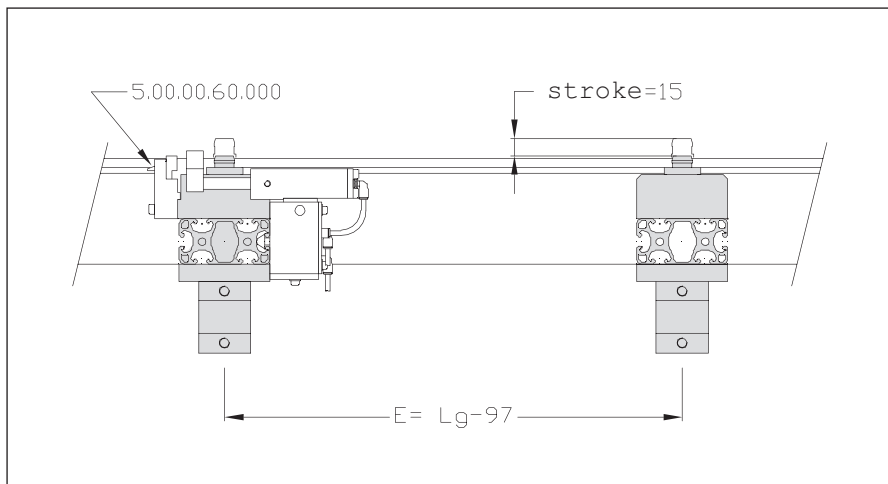

### Designation / Dimensions

**Positioning unit**

**Anti-bouncing back option**

### Order unit

**1 pce**

**1 pce**

### Reference

**5.XX.00.70.000**

**5.00.00.60.000**

XX = Width of workpiece carrier A eg: if the width of workpiece carrier A = 500, XX=05

## Inductive sensor M 12x100

### APPLICATIONS

Detection for the workpiece carrier.

#### Technical data

- ✘ Shielded mounting sensor M12x100
- ✘ LED control display
- ✘ PNP-10-30 VDC
- ✘ Screwed connection
- ✘ Cable 5 m



Designation / Dimensions	Order unit	Reference
Inductive sensor M 12x100	1 set	200.10.200

## Inflatable belt drive transfer

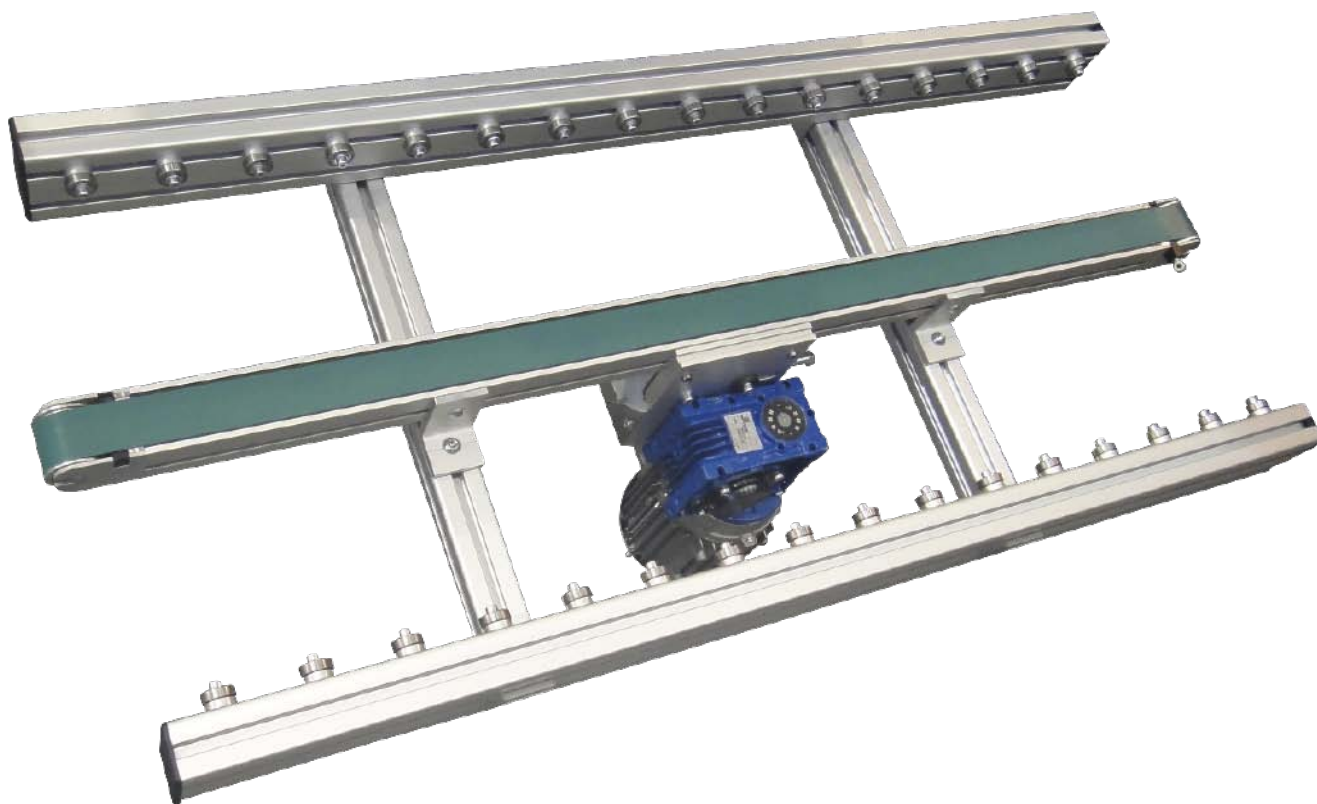







## Inflatable belt drive transfer

### APPLICATIONS

For workpiece carriers in accumulation

#### Technical Data

- ✘ Timing belt drive
- ✘ Pulley with ball bearings
- ✘ PA guiding belts
- ✘ The maximum load limit is supported by ball bearings on each side
- ✘ The use of compressed air lifts the belt and allows the workpiece carriers' conveying

#### Dimensions

- ✘ Width A: 200 to 500 mm
- ✘ Length maxi.: 6000 mm

#### Motorisations

- ✘ 230/400 V Three-Phase 50 Hz  
Speed in m/min (+/- 10%):  
5-10-12-16-18

Maximum pressure: 0.8 bar

The pressure regulator is not supplied in the delivery.

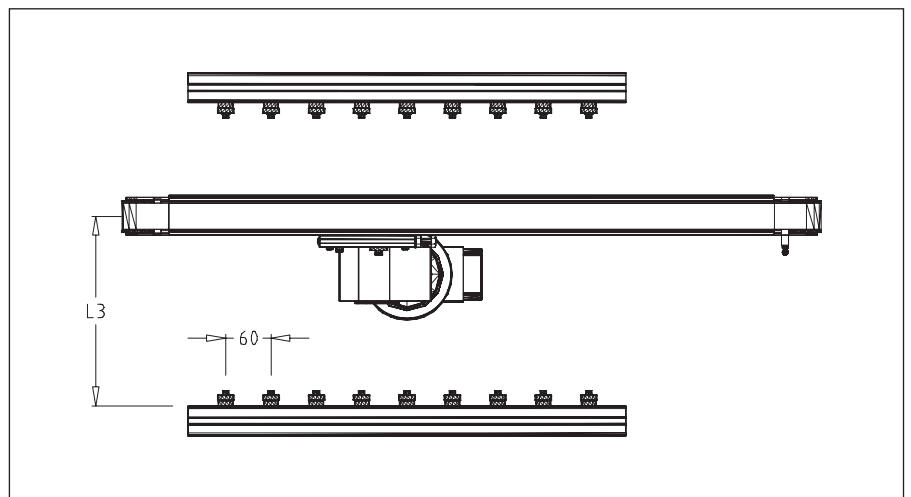
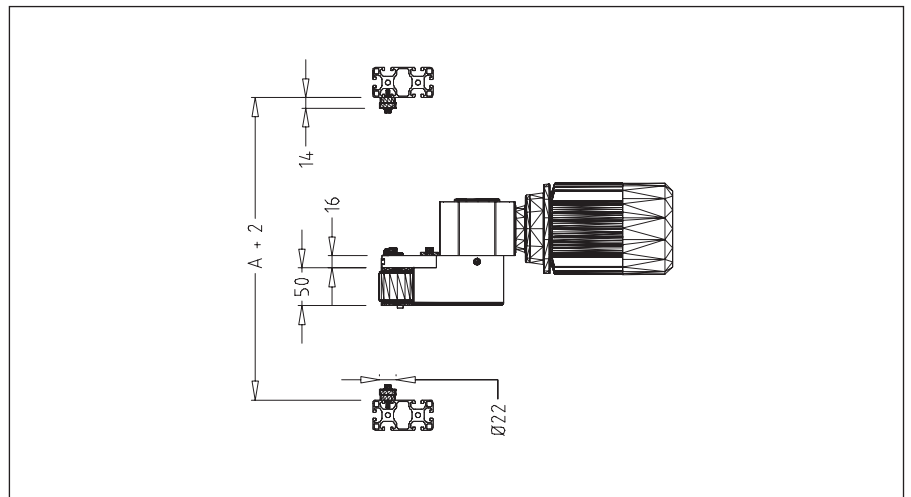
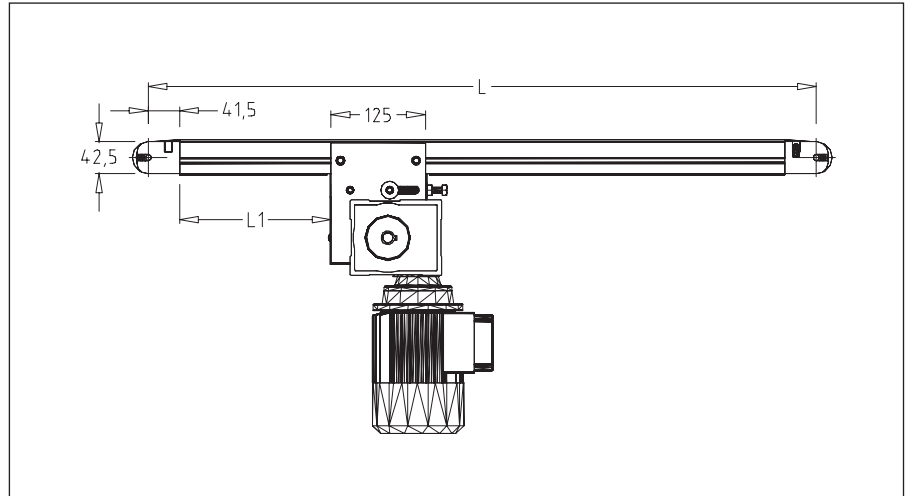

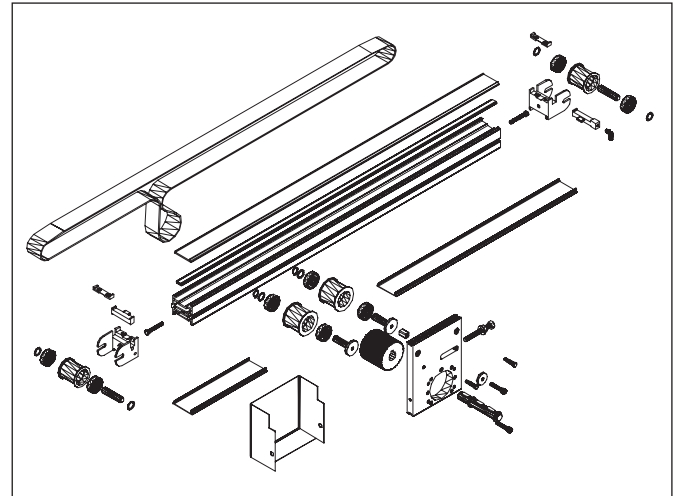
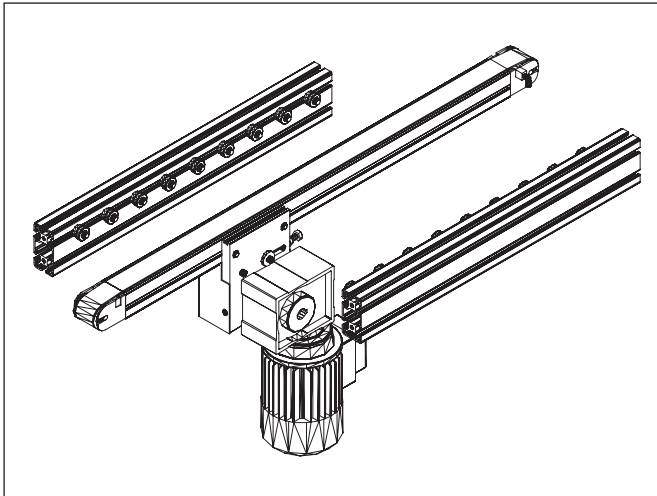

Designation / Dimensions	Order unit	Reference
Inflatable belt drive transfer motor 5 m/min	1 pce	5.00.00.85.000.05
Inflatable belt drive transfer motor 10 m/min	1 pce	5.00.00.85.000.10
Inflatable belt drive transfer motor 12 m/min	1 pce	5.00.00.85.000.12
Inflatable belt drive transfer motor 16 m/min	1 pce	5.00.00.85.000.16
Inflatable belt drive transfer motor 18 m/min	1 pce	5.00.00.85.000.18
Inflatable belt drive transfer bearing length	1 pce	5.00.00.81.000A

## Inflatable belt conveyor holder

### APPLICATIONS

Allow to easily fasten a drive unit with an inflatable belt on a frame.

#### Caractéristiques techniques

- x Aluminium holder
- x Conveyor fastening set:  
Chc 8x20  
Nut 6 St M5
- x Frame fastening set:  
Chc 8x20  
Nut 8 St M8

Maximum distance between axes:  
1 000 mm

Weight: 0,11 kg

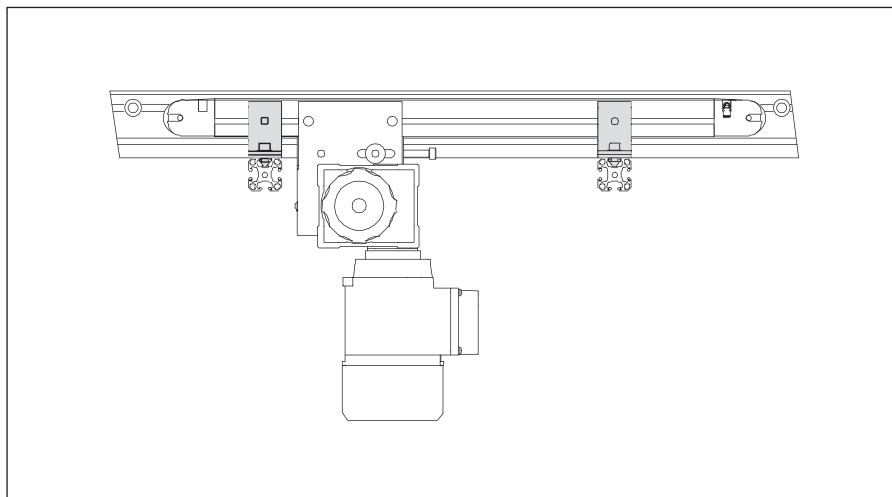
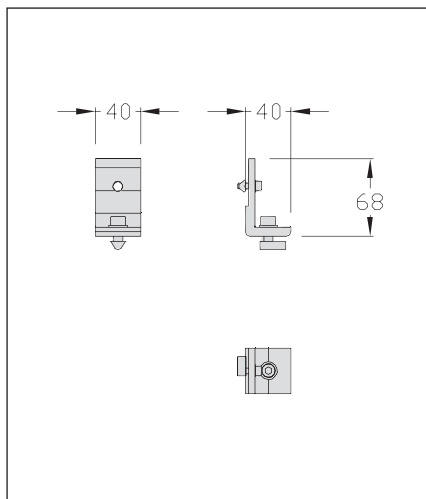

Designation / Dimensions
Inflatable belt conveyor holder

Order unit
1 set

Reference
5.00.00.81.000

# Applications

INFLATABLE BELT







**Our website [www.elcom.fr](http://www.elcom.fr) offers the possibility of configuring yourself on-line the transfer corresponding to your needs.**

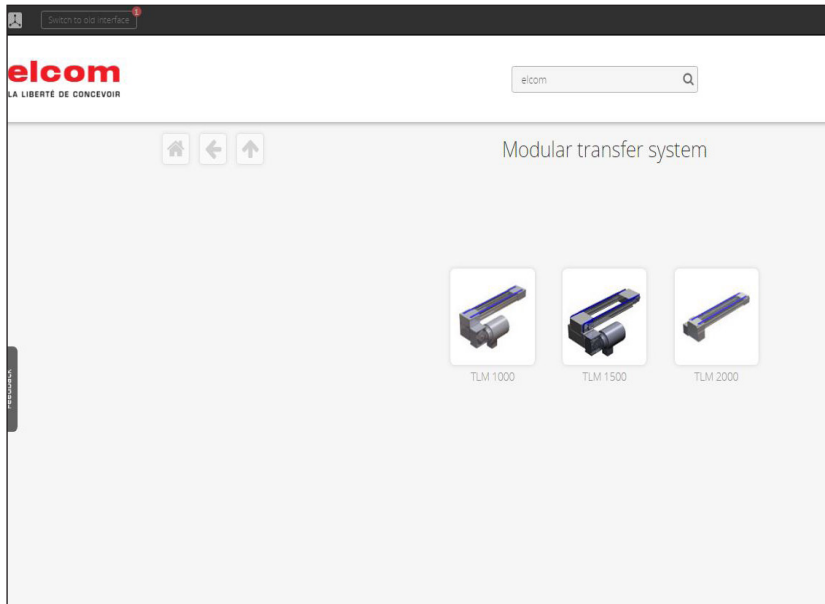

**Download the requested solutions in CAD 2D-3D format.**

All CAD 2D-3D files are downloadable from our website.

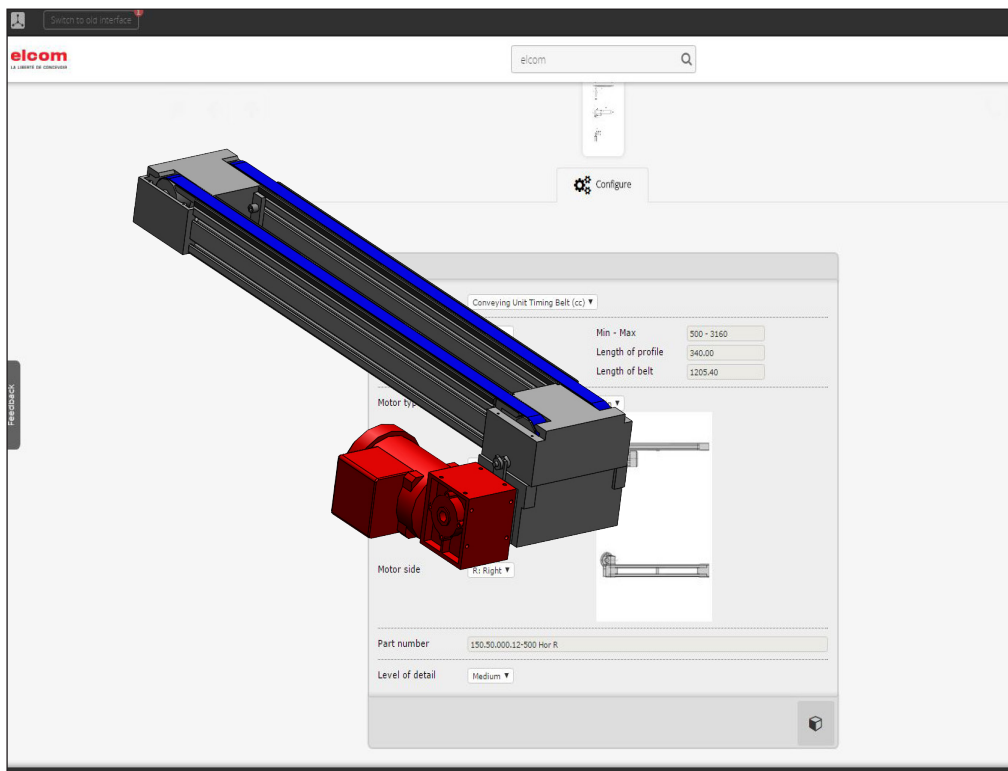



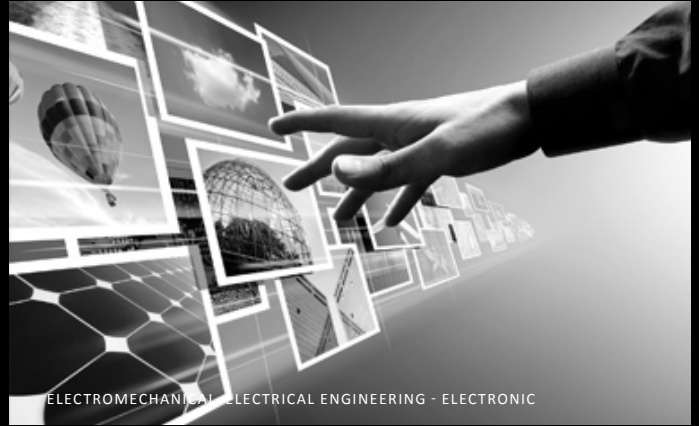

Modular elements for industrialization

# elcom

LA LIBERTÉ DE CONCEVOIR

[www.elcom-automation.com](http://www.elcom-automation.com)



**sinerges** tecmon, s.a.

Técnicas de manipulación y montaje flexible

Rda. Sta. Eulàlia, 35 naves 2-3  
08780 Paltejà | Barcelona  
Teléfono +34 93 663 35 00

[sinerges@sinerges.com](mailto:sinerges@sinerges.com)  
[sinerges.com](http://sinerges.com)

elcom worldwilde

Europe

Asia

Australia

North America

South America

[www.elcom-automation.com](http://www.elcom-automation.com)